

Traffic Analysis in the Intelligent Network

R. Rindzevičius, J. Gvergždys

*Department of Telecommunications and Electronics, Kaunas University of Technology,
Studentų str. 50, LT-51368, Kaunas, Lithuania; e-mail: Ramutis.Rindzevicius@ktu.lt*

Introduction

The fundamental aspect of the intelligent network (IN) is the ability to support the creation of services for the end customer in a rapid manner. Traditional telephone services are not growing much, and to survive in the marketplace, many services providers are looking for new services that will meet the customers' needs and bring in revenue. The advanced IN network provides the multimedia communications include the videophone, video teleconferencing and remote access to multimedia databases.

The IN network basic call model is done. This model describes the operations that the service switching point (SSP) and service control point (SCP) executes. The two types of calls arrive according to a Poisson process with rates λ_1 , λ_2 and are served by two separate IN nodes with exponentially distributed service times. Using the Markov chains exact analytical queueing model was created for IN network call service process. The Markov chains state transition diagram is taken. A careful IN network performance analysis effort is taken by accurate analytical model and by means of simulation. IN network queueing performance measures such as mean queue lengths, the mean waiting times, call loss probabilities in finite buffers system is taken.

Simulation statistics were compared with results given by analytical model. This paper describes a general methodology for analysis call services over IN network.

We also discussed the need for traffic analysis and proposed traffic model that is available for adoption in evaluation of IN systems that carry multimedia traffic.

Some calculations results are taken on graphics.

Companies of all sizes depend on their communication network for mission-critical business transactions. Most of the work on the development of intelligent network technology is generally coordinated by International Telecommunication Union [2,4,5,8]. The intelligent network uses the technology of signaling system number 7 (SS7). The intelligent network service creation requires a structured and disciplined approach, it requires the development of a formal analytical or simulation method or model.

IN is modeled through the IN conceptual model, which is published in ITU-T Rec. Q.1201. The model is organized around two principal elements: (a) basic call processing, (b) intelligent service call processing. Basic call processing is the conventional IN operation of setting up and disconnecting a call and does not entail special feature [1,6]. The call model is a representation of a sequence of procedures executed by an IN points to set up and clear an IN session. For IN performance issues more evolving due the integrated service facilities offered by the network and the employment of IN capabilities across existing networks [11].

Intelligent network architecture

In general, an IN architecture has two dimensions: functional description and performance description [11]. The functional part of the architecture is described through a block schematic with appropriate annotations and is provided in Figure 1. Note that not all functional entities are invoked. The performance part of IN is described through a model of the system in the next section.

A large number of service switching points (SSP) cooperate with the intelligent service control points (SCP) to make IN services accessible to users. The IN architecture model is organized around two principal elements: a) basic call processing, b) IN service call processing. The IN service call is directed to SCP and finally this call is processed like a basic call in SSP with new data. Basic call processing is the conventional operation of setting up and disconnecting a call and does not requires and does not entail special features of IN.

Intelligent network performance model

Call from the users arrives according to a Poisson process intensity λ . This call flow is divided in basic call flow intensity λ_1 and intelligent service call flow intensity λ_2 so, that $\lambda = \lambda_1 + \lambda_2$. Both types calls arrival processes are independent and not correlated. The classical $M/M/1/K$ queue system with finite buffer model is used to analysis system performance measures [14].

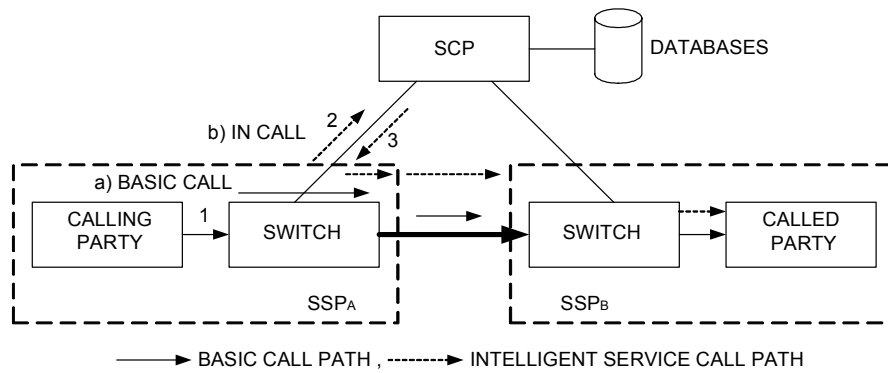

Fig. 1. Functional architecture for the advanced intelligent network

A basic call is served in SSP with intensity $\mu_1=1/T_1$. An intelligent service call is served in SCP with intensity $\mu_2=1/T_2$, where T_1, T_2 - mean value of basic call and intelligent service call processing times in SSP and SCP respectively. Service times T_1, T_2 are exponentially distributed. An intelligent service call is processed in SCP and SSP with intensities μ_1 and μ_2 consequently.

In our case of finite SSP (N) and SCP (K) buffer capacities we have losses in both points of service.

In order to provide guaranteed services, SSP and SCP nodes channels call service intensities μ_1, μ_2 and buffer

resources have to be reserved for all kind of IN calls.

Intelligent network analytical model

The different types of queueing systems are analyzed mathematically to determine performance measures from the description of the system. The IN system shown in the Fig.2 is represented there by means of continuous time Markov chains when the system is in stable state. It is possible to describe the behavior of a finite buffer queueing IN system by means of the each system state probability vector [13].

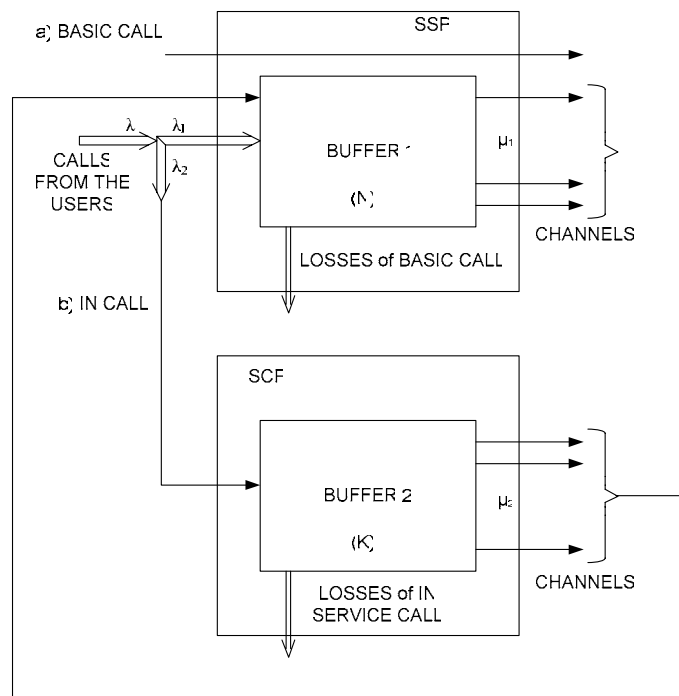

Fig. 2. Basic call and intelligent service call processing model

Each system state is described by four parameters X_1, X_2, x_1, x_2 , where X_1 -number of basic calls in the SSP buffer, X_2 -number of calls in the SCP buffer, $x_1=0$ when the SSP service channel is empty, and $x_1=1$ when the SSP service channel is busy. Analogous to x_1 parameter x_2 represents state of SCP service channel.

Intelligent network model describes a system with a boundary on a finite set of states in which the system can operate as well as a finite state transitions that are possible

from one state to another. System events are associated with the transition from one state to another and the IN performance measures associated with each event are evaluated. Fig. 3 shows IN system Markov chains when SSP and SCP buffer capacities equal 2 ($N=2, K=2$). Using the global balance concept, we can easily write down the following equations (1) for system state vector probability evaluation.

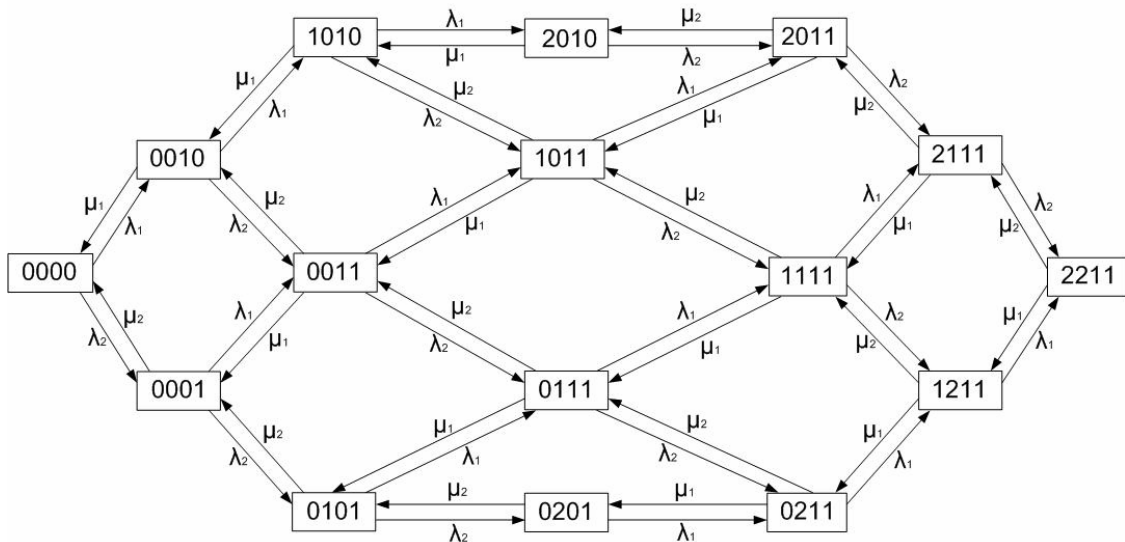

Fig. 3. Continuous-Time Markov chains for the intelligent network call service with call losses

$$\begin{cases}
 \mu_1 \cdot P_{0010} + \mu_2 \cdot P_{0001} - (\lambda_1 + \lambda_2) \cdot P_{0000} = 0; \\
 \mu_1 \cdot P_{0011} + \mu_2 \cdot P_{0101} + \lambda_2 \cdot P_{0000} - (\mu_2 + \lambda_1 + \lambda_2) \cdot P_{0001} = 0; \\
 \mu_1 \cdot P_{1010} + \mu_2 \cdot P_{0011} + \lambda_1 \cdot P_{0000} - (\mu_1 + \lambda_1 + \lambda_2) \cdot P_{0010} = 0; \\
 \mu_1 \cdot P_{1011} + \mu_2 \cdot P_{0111} + \lambda_1 \cdot P_{0001} + \lambda_2 \cdot P_{0010} - (\mu_1 + \mu_2 + \lambda_1 + \lambda_2) \cdot P_{0011} = 0; \\
 \mu_1 \cdot P_{0111} + \mu_2 \cdot P_{0201} + \lambda_2 \cdot P_{0001} - (\mu_2 + \lambda_1 + \lambda_2) \cdot P_{0101} = 0; \\
 \mu_1 \cdot P_{2010} + \mu_2 \cdot P_{1011} + \lambda_1 \cdot P_{0010} - (\mu_1 + \lambda_1 + \lambda_2) \cdot P_{1010} = 0; \\
 \mu_2 \cdot P_{2011} + \lambda_1 \cdot P_{1010} - (\mu_1 + \lambda_2) \cdot P_{2010} = 0; \\
 \mu_1 \cdot P_{2010} + \mu_2 \cdot P_{1111} + \lambda_1 \cdot P_{0011} + \lambda_2 \cdot P_{1010} - (\mu_1 + \mu_2 + \lambda_1 + \lambda_2) \cdot P_{1011} = 0; \\
 \mu_1 \cdot P_{1111} + \mu_2 \cdot P_{0211} + \lambda_1 \cdot P_{0101} + \lambda_2 \cdot P_{0011} - (\mu_1 + \mu_2 + \lambda_1 + \lambda_2) \cdot P_{0111} = 0; \\
 \mu_1 \cdot P_{0211} + \lambda_2 \cdot P_{0101} - (\mu_2 + \lambda_1) \cdot P_{0201} = 0; \\
 \mu_2 \cdot P_{2111} + \lambda_1 \cdot P_{1011} + \lambda_2 \cdot P_{2010} - (\mu_1 + \mu_2 + \lambda_2) \cdot P_{2011} = 0; \\
 \mu_1 \cdot P_{2111} + \mu_2 \cdot P_{1211} + \lambda_1 \cdot P_{0111} + \lambda_2 \cdot P_{1011} - (\mu_1 + \mu_2 + \lambda_1 + \lambda_2) \cdot P_{1111} = 0; \\
 \mu_1 \cdot P_{1211} + \lambda_1 \cdot P_{0201} + \lambda_2 \cdot P_{0111} - (\mu_1 + \mu_2 + \lambda_1) \cdot P_{0211} = 0; \\
 \mu_2 \cdot P_{2211} + \lambda_1 \cdot P_{1111} + \lambda_2 \cdot P_{2011} - (\mu_1 + \mu_2 + \lambda_2) \cdot P_{2111} = 0; \\
 \mu_1 \cdot P_{2211} + \lambda_1 \cdot P_{0211} + \lambda_2 \cdot P_{1111} - (\mu_1 + \mu_2 + \lambda_1) \cdot P_{1211} = 0; \\
 \lambda_1 \cdot P_{1211} + \lambda_2 \cdot P_{2111} - (\mu_1 + \mu_2) \cdot P_{2211} = 0; \\
 \sum_{all} P_{X_1 X_2 x_1 x_2} = 1.
 \end{cases} \tag{1}$$

Once we have obtained the IN system states probabilities P_{XIX2X2} from equations (1), we now proceed to find other IN performance measures.

1) Mean value of calls in SSP buffer is then given by

$$\begin{aligned} \bar{N}_{q1} = & P_{1010} + P_{1011} + P_{1111} + P_{1211} + \\ & + 2(P_{2010} + P_{2011} + P_{2111} + P_{2211}). \end{aligned} \quad (2)$$

2) Mean value of calls in SCP buffer is given by

$$\begin{aligned} \bar{N}_{q2} = & P_{0101} + P_{0111} + P_{1111} + P_{2111} + \\ & + 2(P_{0201} + P_{0211} + P_{1211} + P_{2211}). \end{aligned} \quad (3)$$

3) Basic and intelligent service call losses in the SSP

$$P_{SSP} = P_{2010} + P_{2011} + P_{2111} + P_{2211}. \quad (4)$$

4) Intelligent service call losses in the SCP

$$P_{INS} = P_{0201} + P_{0211} + P_{1211} + P_{2211}. \quad (5)$$

5) Mean value of call losses of IN system for both types of arrivals

$$P_{IN} = \frac{[\lambda_1 + \lambda_2(1 - P_{INS})]P_{SSP}}{\lambda_1 + \lambda_2} + \frac{\lambda_2 P_{INS}}{\lambda_1 + \lambda_2}. \quad (6)$$

6) Mean value of call waiting time in SSP buffer using Little's theorem

$$\bar{W}_{SSP} = \frac{\bar{N}_{q1}}{\lambda_1(1 - P_{SSP}) + \lambda_2(1 - P_{INS})}. \quad (7)$$

7) Mean value of intelligent call waiting time in SCP

$$\bar{W}_{SCP} = \frac{\bar{N}_{q2}}{\lambda_2(1 - P_{INS})}. \quad (8)$$

8) Mean response time for basic calls

$$\bar{R}_{BC} = \bar{T}_1 + \bar{W}_{SSP}. \quad (9)$$

9) Mean response time for intelligent service call

$$\bar{R}_{INS} = \bar{T}_2 + \bar{W}_{SSP} + \bar{W}_{SCP}. \quad (10)$$

10) SSP channel theoretic and real utilizations

$$\begin{cases} \rho_{SSPT} = \frac{\lambda_1 + \lambda_2}{\mu_1}; \\ \rho_{SSPR} = 1 - P_{0000} - P_{0010} - P_{0101} - P_{0201}. \end{cases} \quad (11)$$

11) SCP channel theoretic and real utilizations

$$\begin{aligned} \rho_{SSPT} = \frac{\lambda_2}{\mu_2}; \quad \rho_{SSPR} = & 1 - P_{0000} - P_{0010} - \\ & - P_{0101} - P_{2010}. \end{aligned} \quad (12)$$

12) The probability of empty system

$$P_0 = P_{000}. \quad (13)$$

Results by an analytical model

This steady state performance measures are derived without assuming anything about the queueing discipline and they hold for all queueing disciplines [12].

We estimate IN performance measures such as call losses in finite buffers of SSP and SCP nodes, delay parameters for different λ and μ values.

Evaluation results are given using for this purpose classical one channel queueing models $M/M/1/K$.

$M/M/1/K$ queueing model represents the processes in intelligent network system (Fig. 2) with Poisson call arrivals, infinite buffer capacities (N, K) in both IN nodes, exponentially distributed service times (T_1, T_2), and the calls are served by a single separate channels for SSP and SCP nodes with constant service intensities respectively μ_1, μ_2 .

Some calculated system performance measures results, using an analytical model, are presented in Fig. 4,5,6.

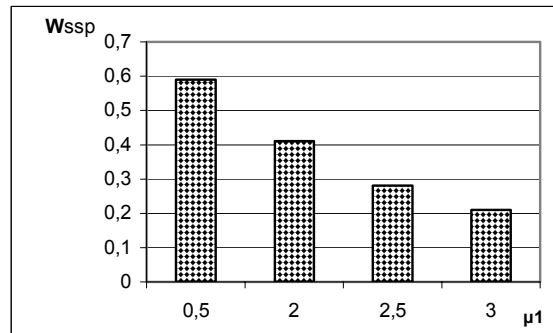

Fig. 4. Mean value of call waiting time in SSP as function of μ_1 , when $\lambda_1 = \lambda_2 = 1, \mu_2 = 1, N=K=2$

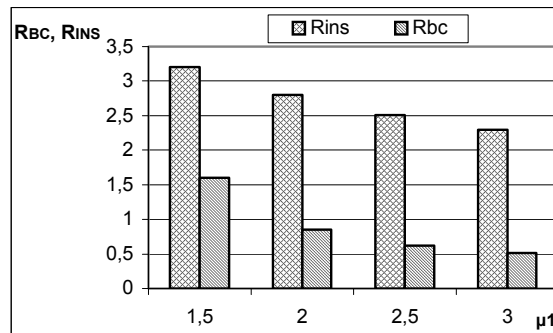

Fig. 5. Mean value of call response time in system as function of μ_1 , when $\lambda_1 = \lambda_2 = 1, \mu_2 = 1, N=K=2$

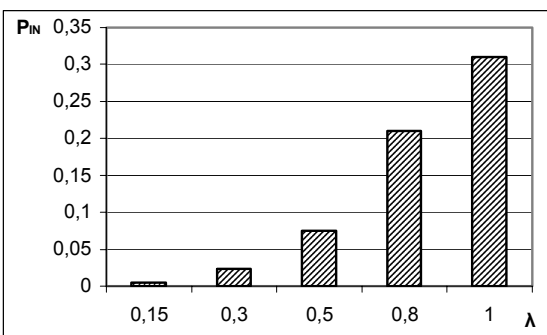

Fig. 6. Mean value of call losses in IN system for both types of arrivals as function of λ , when $\lambda_1=\lambda_2, \mu_1=\mu_2=2, N=K=2$

Intelligent Network performance parameters permit operators to determine if a system is meeting the requirements for quality of services, and if a system is being used efficiently.

Conclusions

In particular, we have outlined an analytical model to evaluate a service of the intelligent network performance measures. An analytical model is extremely accurate in the case of the basic and intelligent service call Poisson traffic; exponential service times in SCP and SSP nodes. Both call flows from users are independent and not correlated. The classical $M/M/1/K$ queue system with finite buffer model is used to analysis IN performance measures. Queuing performance measures such as mean queue length, mean waiting times, loss probabilities in finite buffers, call response time is computing using global balance equation for the Markov chains. An exact system analytical model is very complicated when the buffer sizes in SSP and SCP are large, because Markov chains has a large number of states and more general study of system may be achieved via simulation.

IN performance evaluation constitutes a widely accepted technique for estimating the system response and provide valuable feedback to system design process.

The results reported here support the evaluation process of services provided by IN network operators.

We fell that the proposed approach represents a possible starting point for future research works analyzing the processes in intelligent service systems.

References

1. **Veeraraghavan La Porta M., Lai W.** An Alterantive Approach to Call/Connection Control in Broadband Switching Systems // *IEEE Commun. Mag.* 33, 1995. – P. 90–96.
2. **ITU-T Recommendation Q.1203.** “Intelligent Network Global Functional Plane Architecture.”
3. **Tsolas N., Abdo G., Bottheim R.** Performance and overload considerations when introducing IN into an existing network // *Proceedings of International Zurich Seminar on Digital Communications, Intelligent Networks and their applications.* – 1992.
4. **ITU-T Recommendation Q.1201.** “Principles of Intelligent Network Architecture”.
5. **ITU-T Recommendation Q.1202.** “Intelligent Network Service Plane Architecture”.
6. **Black U.,** *The Intelligent Networks.* – Upper Saddle River: Prentice Hall PTR. – 1998.
7. **Brennan R.** et al. *Evolutionary Trends in Intelligent Networks,* *IEEE Commun. Mag.,* June 1998. – P. 68–76.
8. **ITU-T Recommendation Q.1224.** *Distributed functional plane for Intelligent Network CS–2.* – 1997.
9. **Lesley U.** *The Intelligent Network Opens Up for Business // Telecommunications.* – 30(11). – 1996.
10. **Christensen G.** et al. *Wireless Intelligent Networking,* Boston: Artech House, 2001.
11. **Venieris Hussman H.** *Intelligent Broadband Networks.* – Chichester, John Wiley&Sons, 1998.
12. **Chee Hock Ng.** *Queueing Modeling Fundamentals.* Chichester: John Wiley&Sons, 1996.
13. **Gvergždys J., Mikšys A., Šimkevičius S, Rindzevičius R.** *Prioritetinių paraiškų srautų aptarnavimo $M/M/1/n$ sistemos analizė// Elektronika ir elektrotechnika.-Kaunas: Technologija, 2004. – Nr. 2(51). – P.52-55.*
14. **Rindzevičius R.** *Teletrafiko teorija.* – Kaunas: Technologija, 2003. – 252 p.

Pateikta spaudai 2004 11 08

R. Rindzevičius, J. Gvergždys. Intelektualaus tinklo apkrovos srautų analizė // Elektronika ir elektrotechnika. – Kaunas: Technologija, 2005. – Nr. 1(57). – P. 28–33.

Pagrindinė intelektualaus tinklo paskirtis – nedelsiant suteikti vartotojui jo reikalaujamas paslaugas. Tradicinių telefoninių paslaugų poreikis vis mažėja, todėl paslaugų teikėjai, atsižvelgdami į paslaugų rinkos pokyčius, ieško naujų paslaugų, kurios tenkintų vartotojo poreikius ir duotų teikėjams pelno. Šiuolaikiniai intelektualūs tinklai teikia vartotojui daugialypes telekomunikacijų paslaugas: balso, vaizdo perdavimo, vaizdo konferencijos ryšio sudarymo, prieigos prie įvairaus tipo duomenų ir informacijos bazių.

Pateikiamas intelektualaus tinklo bazinio skambučio ir intelektualaus aptarnavimo skambučio modelis. Šis modelis atspindi procesus, vykstančius skambučio aptarnavimo metu intelektualaus tinklo skambučių komutavimo ir valdymo mazguose. Dviejų tipų skambučių duomenų paketų Puasono srautai intensyviai λ_1, λ_2 patenka į sistemą ir yra aptarnaujami dviem skirtingais kanalais. Paketų ilgiai ir jų perdavimo kanaluose trukmės pasiskirsčiusios pagal eksponentinį dėsnį. Pasitelkus Markovo grandinės sudarytas tikslus skambučių aptarnavimo sistemoje modelis. Pateikta Markovo grandinės perėjimo iš vienos būsenos į kitą diagrama. Intelektualaus tinklo darbo našumas tiksliai įvertintas analitiniu būdu apskaičiuojant šiuos sistemos darbą nusakančius parametrus: vidutinės laukimo eilėje trukmės, skambučių neaptarnavimo tikimybes, vidutinius eilės ilgius esant ribotoms buferių talpoms. Rekomenduojama sudėtingesnės sistemos analizei taikyti imitacinio modeliavimo metodus, nes, esant didelei buferių talpai, Markovo grandinės tampa labai komplikuotos ir imlios skaičiavimų. Il. 6, bibl.14 (anglų kalba; santraukos lietuvių, anglų ir rusų k.).

R. Rindzevičius, J. Gvergždys. Traffic Analysis in the Intelligent Network // Electronics and Electrical Engineering. – Kaunas: Technologija, 2005. –No. 1(57). – P. 28–33.

The fundamental aspect of the intelligent network (IN) is the ability to support the creation of services for the end customer in a rapid manner. Traditional telephone services are not growing much, and to survive in the marketplace, many services providers are looking for new services that will meet the customers' needs and bring in revenue. The advanced IN network provides the multimedia communications include the videophone, video teleconferencing and remote access to multimedia databases.

The IN network basic call model is done. This model describes the operations that the service switching point (SSP) and service control point (SCP) executes. The two type data packets of each call arrive according to a Poisson process with rates λ_1 , λ_2 and are served by two separate channels with exponentially distributed transmission time. Using the Markov chains exact analytical queueing model was created for IN network call service process. The Markov chains state transition diagram is taken. A careful IN network performance analysis effort is taken by accurate analytical model. IN network queueing performance measures such as mean queue lengths, the mean waiting times, call loss probabilities in finite buffers system is taken. An exact system analytic model is very complicated when the buffer sizes in SSP and SCP are large, because Markov chains has a large number of states and more general study of system may be achieved via simulation. Ill. 6, bibl. 14 (in English; summaries in Lithuanian, English and Russian).

Р. Риндзевичюс, Ю. Гвергждис. Исследование потоков вызовов в интеллектуальной сети связи // Электроника и электротехника. – Каунас: Технология, 2005. – № 1(57). – С.28–33.

Основное назначение интеллектуальной сети (ИС) – немедленно предоставить пользователю его желаемую услугу. Потребность традиционных телефонных услуг все уменьшается, поэтому операторы, предоставляющие услуги и оценивая изменения в рынке телекоммуникационных услуг, ищут новых услуг, удовлетворяющих их клиентов и дающих доход. Современные ИС предоставляют пользователю разные телекоммуникационные услуги, такие как голос, видео, видеоконференция, дата, доступ к разным банкам данных и информации. Предоставляется модель обслуживания базового и интеллектуального звонка в ИС. Модель обслуживания базового и интеллектуального звонка в ИС отображает процессы в узлах коммутации и управления.

Пуассоновские потоки данных от двух типов звонков интенсивностью λ_1 , λ_2 поступают в систему и обслуживаются двумя различными каналами. Длина пакетов данных и время их передачи по каналам распределено экспоненциально. На основе цепи Маркова создана модель обслуживания звонка и получена система линейных алгебраических уравнений для определения вероятностей состояний марковской цепи. Для точной оценки производительности ИС приведены выражения для расчета среднего времени ожидания, средней длины очереди, вероятности необслуживания звонка в случае конечной емкости буферов. Рекомендуется для анализа более сложной ИС системы применять методы моделирования, так как аналитический метод анализа становится очень сложным и трудоемким. Ил.6, библ.14 (на английском языке; рефераты на литовском, английском и русском яз.).

DOI: 10.5755/j02.eie.10332