

Modeling and Investigation of Active Noise Control System

A. Dumčius, A. Bartušis

*Department of Electronics Engineering, Kaunas University of Technology,
 Studentų str. 50-142, LT-51368 Kaunas, Lithuania, phone: +370 37 300520, e-mail: antanas.dumcius@ktu.lt*

Introduction

For the protection of the auditory organs from the harmful effect of loud sound signals it is using passive and active means of protection. Passive protection is very effective against mid- and high-frequency noise, but low-frequency noise generated by engines, motors, and fans is more challenging. Low-frequency noise waves, prevalent in many industrial environments, are longer, can travel great distances, and can penetrate passive barriers. Active Noise Control (ANC) is the only effective method of attenuating low-frequency noise. ANC is achieved by electronically coupling a noise wave with its exact mirror image, thereby canceling the noise. In the mid- 1970s was the recognition that many noises, particularly those produced by man-made machines, are periodic or tonal. This tonal noise allowed for a more effective solution because each repetition created a predictable harmonic pattern, which enabled the electronic system to generate a more accurate anti-noise signal. In noise room it is suitably to use passive protection devices [1]. The active anti-noise systems with distributed mode loudspeakers are applicable for the protection of adjacent rooms [2] and the noise level in the adjacent room can be calculated [3].

In most environments, there is noise in a wide frequency range. In this way the characteristics of an acoustic noise source and the environment are not constant, the frequency content, amplitude, phase, and velocity of the undesired noise are non-stationary. An ANC system must be adaptive in order to regularize with these changing characteristics. For the realization of this task, it adapts the active filters, which change their coefficients in such a way as to minimize the error signal.

For the reduction of ambient noises it adapts wide-band or narrow-band ANC with the loop of direct or feedback [4].

ANC systems are based on one of two methods. Feed forward control is where a coherent reference noise input is sensed before it propagates past the canceling speaker. Feedback control is where the active noise controller attempts to cancel the noise without the benefit of an upstream reference input [4].

A structure of algorithm of broadband ANC system is

shown in Fig. 1. Usually in the ideal active noise control system is used an adaptive filter $W(z)$ to estimate the response of an unknown primary acoustic path $P(z)$ between the reference input sensor and the error sensor.

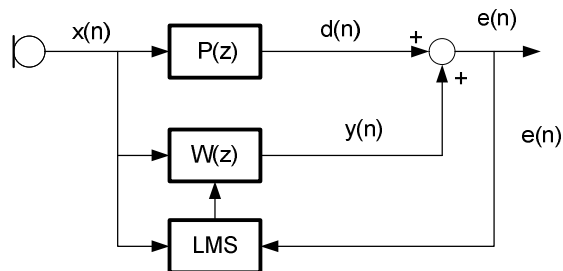

Fig. 1. The structure of algorithm of broadband ANC system; here $P(z)$ – primary acoustic path; $W(z)$ – adaptive filter; LMS – least-mean-square algorithm; $x(n)$ – discrete-time signal from environment; $d(n)$ – primary noise; $y(n)$ – adaptive filter output; $e(n)$ – error signal; $z=A(\cos\phi+j\sin\phi)$

Usually in the ideal ANC system is used an adaptive filter $W(z)$ to estimate the response of an unknown primary acoustic path $P(z)$ between the reference input sensor and the error sensor. The z -transform of $e(n)$ signal can be expressed as:

$$E(z) = D(z) + Y(z) = X(z)[P(z) + W(z)], \quad (1)$$

where $E(z)$ is the error signal, $X(z)$ is the input signal, and $Y(z)$ is the adaptive filter output. After the adaptive filter $W(z)$ has converged, $E(z) = 0$. Equation (1) becomes:

$$W(z) = -P(z), \quad (2)$$

for this case:

$$y(n) = -d(n). \quad (3)$$

Therefore, the adaptive filter output signal $y(n)$ will have the same amplitude but opposite phase with the primary noise signal $d(n)$. When $d(n)$ and $y(n)$ signals are acoustically summarized, the residual error signal becomes

zero, resulting in cancellation of both sounds based on the principle of superposition.

The error signal $e(n)$ is measured by the error sensor in acoustic chamber where the primary noise signal $d(n)$ and anti-noise signal $y(n)$ is mixed. The anti-noise signal $y(n)$ can be modified by the secondary-path function $H(z)$ in the acoustic channel from $y(n)$ to $e(n)$, in this same way as the primary noise signal $x(n)$ is modified by the primary path $P(z)$ from the noise source to the error signal sensor. Therefore, it is necessary to compensate for $H(z)$ [5].

The structure of algorithm of broadband ANC system that includes the secondary path $H(z)$ is shown in Fig. 2.

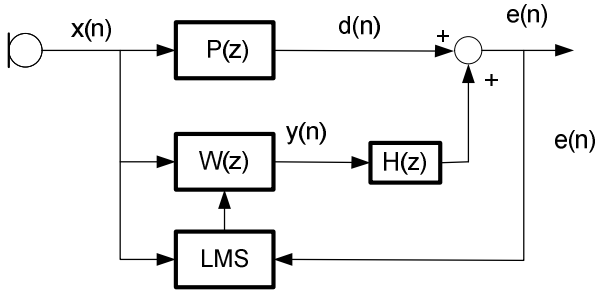

Fig. 2. The structure of algorithm of broadband ANC system within the secondary path $H(z)$

In this way the z -transform of error signal $e(n)$ can be expressed as:

$$E(z) = X(z) \cdot P(z) + X(z) \cdot W(z) \cdot H(z). \quad (4)$$

If the function $W(z)$ has sufficient order, after the convergence of the adaptive filter, the residual error signal must be zero ($E(z) = 0$). For this case for the realization of the optimal transfer function must be required the condition:

$$W(z) = -P(z)/H(z). \quad (5)$$

Secondary path $H(z)$ will be introduce signal delay, which is not in the primary path $P(z)$. This is the overall limiting in broadband feed forward control systems [4].

In the active noise systems usually is used the least mean-squared or Kalman algorithm [6, 7].

Experiment methods and results

Testing of experimental head sets was conducted according to the requirements of standard ISO 4869-2:1994 with the use of the designed and prepared dummy type Acoustic Test Fixture [7, 8, 9]. The channel of human ear in the dummy was approximated by the cylinder with a length of 3 cm and with a diameter of 0.8 cm. In the process of measurement the computer program SoundCheck 7.0 was used [8].

The sound pressure level (SPL) with presence and absence of head sets on the dummy was measured. The difference of measured pressure levels of sound are called by Insertion Loss (IL). In the field of research it was

created by system of loudspeakers 80 dB SPL of pink noise. The level of background noise it was measured by the gauge of noise of the type Mastech MS6701. Measurement procedure: 1. It was measured SPL inside the dummy without the head sets i.e., Open-Ear Spectrum (OE). 2. It was measured SPL within ear-channel of dummy with the head sets but with the ANC system switched off, thus was determined the passive suppression of noise by the head sets, i.e., Passive-Protected-Ear Spectrum (PP). 3. It was measured the total suppression of noise with switch on the ANC system, i.e., Total Protected Spectrum (TP).

The measurements were carried out in the range frequencies from 20 Hz to 8000 Hz (according to standard).

The basic parameters of the head sets noise reduction were calculated from the results of measurement:

1. Passive Insertion Loss was calculated from the formula

$$IL_p = OE - PP, [dB]. \quad (6)$$

2. Total Insertion Loss was calculated from the formula

$$IL_T = OE - TP, [dB]. \quad (7)$$

3. Active Insertion Loss was calculated from the formula

$$IL_A = PP - TP, [dB]. \quad (8)$$

The structure of experiment equipment is shown in Fig. 3.

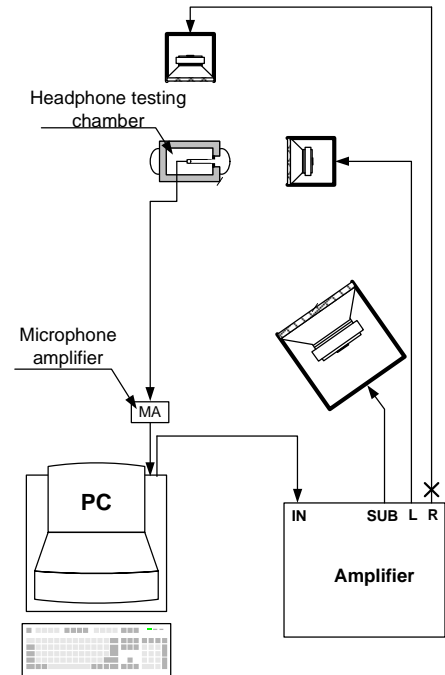

Fig. 3. The structure of experiment equipment

In the case of measurement dependence IL_T on the environment noise SPL the level of ambient noise it changed from the nominal level of 80 dBA within the limits of ± 10 dBA.

The block diagram of experimental equipment is shown in Fig 4.

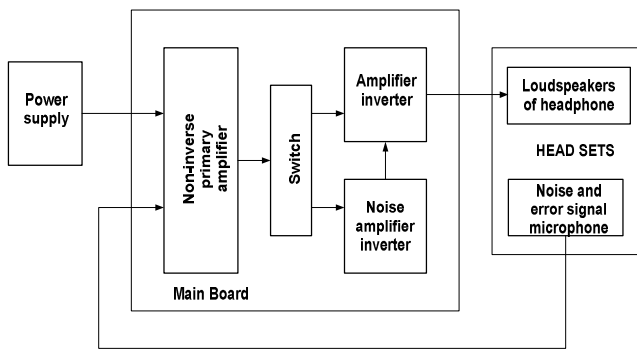

Fig. 4. The block diagram of experimental equipment

The results of measurement and calculation features of the experimental head sets are shown in figures from Fig. 5 to Fig. 9.

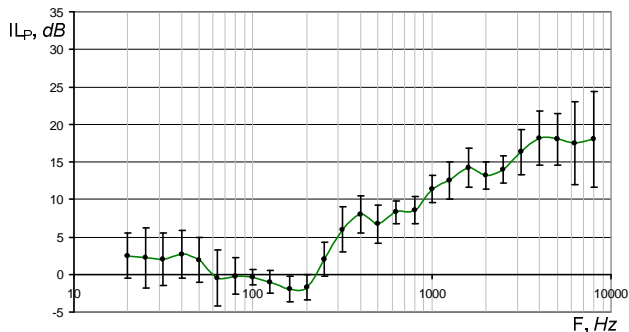

Fig. 5. The passive insertion loss of experimental head sets

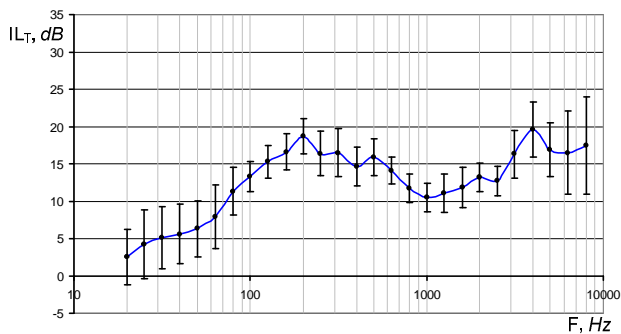

Fig. 6. The total insertion loss of experimental head sets

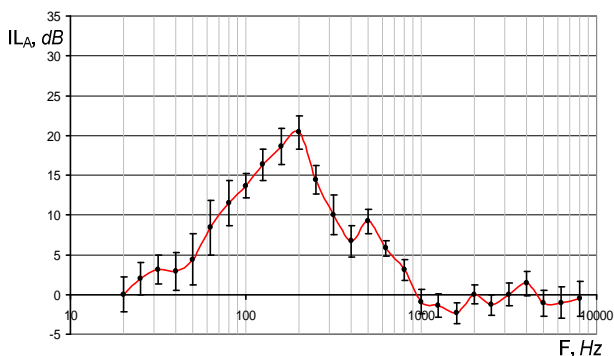

Fig. 7. The active insertion loss of experimental head sets

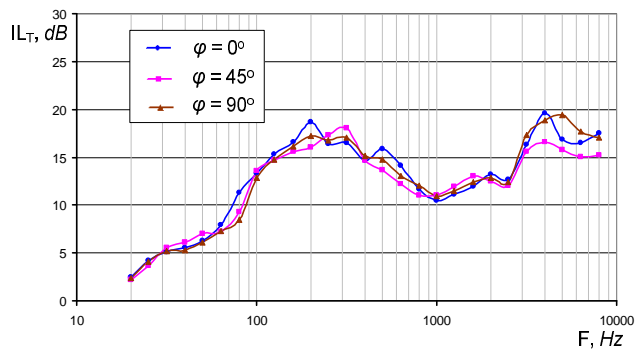

Fig. 8. The dependence IL_T on the angle of head sets rotation

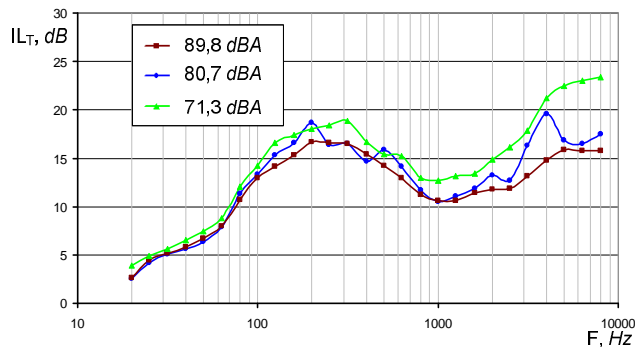

Fig. 9. The dependence IL_T on the environment noise SPL

For the comparative analysis analogous measurements were carried out also with the typical head sets industrial production with ANC system. Same results of measurement features of head sets industrial production are shown in figures from Fig. 10 to Fig. 12.

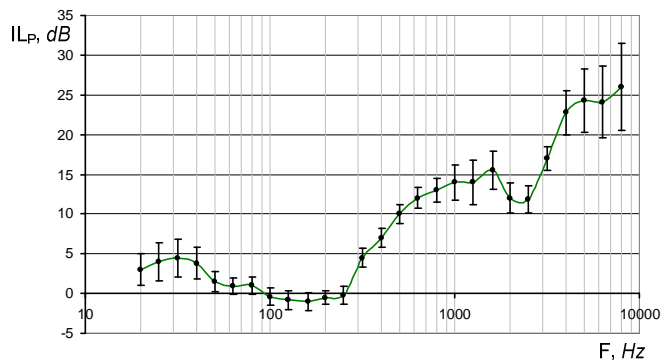

Fig. 10. The passive insertion loss of industrial production head sets

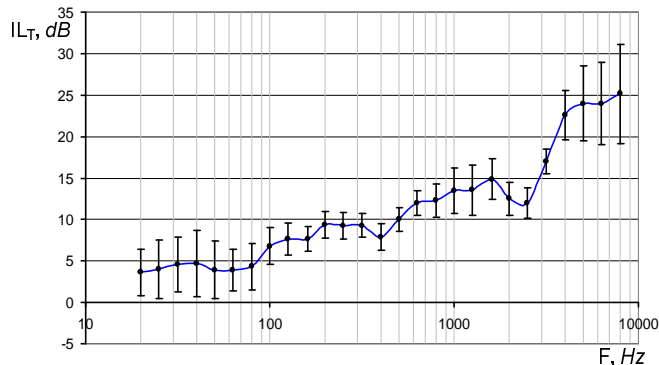

Fig. 11. Total insertion loss of industrial production head sets

The passive insertion loss of industrial production head sets were more than experimental head sets.

The total insertion loss in low frequency range from 31.5 Hz to 800 Hz of experimental head sets were more than head sets type Philips SBC HN110.

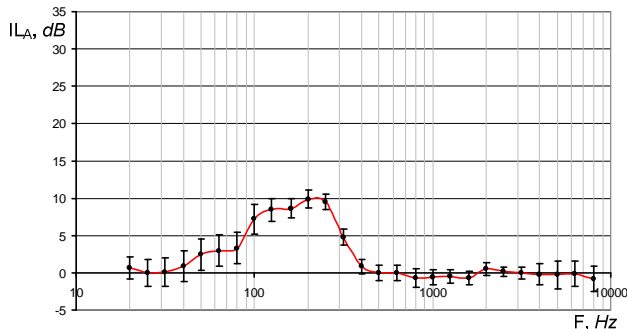

Fig. 12. The active insertion loss of industrial production head sets

The active insertion loss of experimental head sets were more than head sets industrial production in the frequency range from 25 Hz to 900 Hz. At the frequency of 300 Hz the Active insertion loss of noise was more even on 20 dB.

Conclusions

1. The total suppression of noise by experimental head sets in range frequencies from 100 Hz to 300 Hz, where the suppression of noise by passive means little is effective, is achieved the suppression of noise within the limits of 10-20 dB.
2. The mechanism of the passive suppression of noise plays the basic role in the noise suppression of the head sets with the active noise control system in over a wide range the frequencies.
3. The angle of head sets rotation relative to the direction of the noise source it have a little influence to the total

A. Dumčius, A. Bartušis. Modeling and Investigation of Active Noise Control System // Electronics and Electrical Engineering. – Kaunas: Technologija, 2009. – No. 3(91). – P. 27–30.

The results of modeling and investigation of experimental head set with active noise control system are presented. On results of simulation the rated step size of adaptive algorithm was choose. The structure of experiment equipment and measurement results of the passive insertion loss, total insertion loss, active insertion loss, dependence of total insertion loss on the angle of experimental head sets rotation and dependence of total insertion loss on the sound pressure level of environment noise are presented. Ill. 12, bibl. 9 (In English; summaries in English, Russian and Lithuanian).

A. Думчюс, А. Бартушис. Моделирование и исследование активной системы подавления шума // Электроника и электротехника. – Каунас: Технология, 2009. – № 3(91). – С. 27–30.

Представлены результаты моделирования и исследования экспериментальных наушников с системой активного подавления шума. Приведена структурная схема оборудования эксперимента и результаты измерения экспериментальных наушников с системой активного подавления шума характеристик: пассивного шума подавления, суммарного шума подавления, активного шума подавления, зависимости суммарного шума подавления от угла поворота наушников и уровня шума в окружающей среде. Ил. 12, библи. 9 (на английском языке; рефераты на английском, русском и литовском яз.).

A. Dumčius, A. Bartušis. Aktyvios triukšmo slopinimo sistemos modeliavimas ir tyrimas // Elektronika ir elektrotechnika. – Kaunas: Technologija, 2009. – Nr. 3(91). – P. 27–30.

Pateikta ausinių su aktyviaja triukšmo slopinimo sistema modeliavimo ir tyrimo rezultatai. Remiantis modeliavimo rezultatais parinktas nominalus adaptyvaus algoritmo žingsnis. Pateikti eksperimentinių ausinių pasyvaus slopinimo, suminio slopinimo ir aktyvaus slopinimo priklausomybės nuo ausinių pasukimo kampo ir ausinių suminio slopinimo priklausomybės nuo aplinkos triukšmo lygio matavimo rezultatai bei eksperimentuose naudotos įrangos struktūros schema. Il. 12, bibl. 9 (anglų kalba; santraukos anglų, rusų ir lietuvių k.).

insertion loss both of experimental and industrial head sets. 4. It is defined; that with an increase in the level of ambient noise level decreases both active insertion loss and passive insertion loss of head sets with ANC.

5. The active insertion loss of experimental head sets were more than head sets industrial production in the frequency range from 25 Hz to 900 Hz.

References

1. **Požėra A., Volkovas V.** Acoustic Fields Horizontal Layer Reconstruction // *Matavimai. – Kaunas: Technologija, 2007. – Nr.2(40). – P. 17–20.*
2. **Dumčius A., Bernatavičius L.** The Research of the of DML Loudspeakers Properties // *Electronics and Electrical Engineering. – Kaunas: Technologija, 2008. – No. 8(88). – P. 47–50.*
3. **Dumčius A.** Simulation of Sound Field in a Classroom // *Electronics and Electrical Engineering. – Kaunas: Technologija, 2007. – No. 5(77). – P. 73–76.*
4. **Nelson P. A., Elliott S. J.** Active Control of Sound. – Toronto: Academic Press, Inc., 1993.
5. **Nishimura M.** Some Problems of Active Noise Control for Practical Use // *Proc. Int. Symp. Active Control of Sound and Vibration. – Tokyo. – 1991. – P. 157–164.*
6. **Kuo S. M., Morgan D. R.** IEEE Active Noise Control: A Tutorial Review // *Proc. of The IEEE. – 1999. – Vol. 87, 6. – P. 934–945.*
7. **Morgan D. R., Thi J. C.** A Delay less Sub band Adaptive Filter Architecture // *IEEE Transactions on Signal Processing. – 1995. – Vol 43, 8. – P. 1820–1830.*
8. Insertion loss testing of active noise reduction headsets using acoustic fixture. Accessed at: www.eecg.utoronto.ca/~willy/anr.pdf.
9. ISO 4869-2:1994. Acoustics -- Hearing protectors -- Part 2: Estimation of effective A-weighted sound pressure levels when hearing protectors are worn. Accessed at: http://www.iso.org/iso/iso_catalogue/catalogue_tc/catalogue_detail.htm?csnumber=10851.

Received 2009 01 20

DOI: 10.5755/j02.eie.10273