

## Influence Of The Inverter Boost Voltage On The Transients Of Variable Speed Drive

**R. Rinkevičienė, V. Batkauskas**

*Automation Department, Vilnius Gediminas Technical University,  
 Naugarduko str. 41, LT-03227, Vilnius, Lithuania; e-mail: vygintas.batkauskas@el.vgtu.lt*

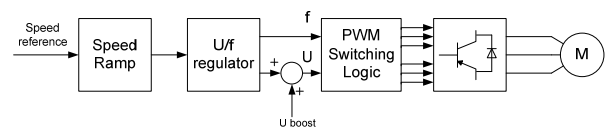
### Introduction

The operation of induction motors in the so-called constant volts per hertz ( $U/f$ ) mode has been known for many decades, and its principle is well understood [1]. Method and apparatus for providing adequate breakaway torque for the AC motors started in a system in which inverter supplies electric power to the motors are presented. The output voltage of the source is substantially increased for an initial predetermined starting period to provide adequate breakaway torque, the voltage thereafter being reduced to a level corresponding to a predetermined desired constant ratio relative to output frequency. Systems with a static load with and without the starting voltage boost are analyzed. Different output frequencies are used to find out the optimal relation between voltage and frequency in scalar control method especially in low speed region.

### Basic fixed $U/f$ drives

The control strategy of a fixed  $U/f$  drive is usually open-loop control as shown in Fig. 1. The speed reference is taken from an external source and controls the voltage and frequency applied to the motor. The speed reference is first fed into a ramp circuit to convert a step change in the speed request to a slowly changing signal. This prevents electrical and mechanical shock to the speed control system. The acceleration and deceleration ramp times can be set by the user. The signal is then passed to a section that sets the magnitude of both the voltage and frequency fed to the motor. The  $U/f$  ratio between the voltage and frequency is kept constant at all times. It also sets the rate of change of these two values, which determines the motor acceleration. The base voltage and base frequency used for this ratio are taken from the motor nameplate. Finally, the signal passes to the PWM switching logic module that controls the switching pattern of the IGBT switches to provide the voltage pattern at the output terminals according to the PWM algorithm [2].

There is usually no speed feedback from the motor. It is assumed that the motor is responding to and following the output frequency.



**Fig. 1.** Block control diagram of fixed  $U/f$  drive

This method of open loop fixed  $U/f$  control is adequate for controlling steady-state conditions and simple applications, such as pumps, fans and conveyors, which allow a lot of time for speed changes from one level to another and where the consequences of the changes in the process are not severe. This type of drive is not well suited to the following:

- Applications where motors run at low speeds (below 10 Hz). The torque at low speed is generally poor because the stator voltage drop significantly affects the magnitude of the flux-producing current. Many  $U/f$  drives include a “start boost” when allows the  $U/f$  ratio to be boosted at starting in an attempt to improve the flux and consequently the starting torque [3];
- Applications which require higher dynamic performance;
- Applications that require direct control of motor torque rather than motor frequency;
- The dynamic performance of this type of drive with shock loads is poor [4];

### Model of variable speed drive

Dynamic performance of an AC induction motor is complex problem taking into account three-phase rotor windings moving with respect to three-phase stator windings. The coupling coefficient changes continuously with the change of rotor position  $\theta_r$  and motor model is described by differential equations with time varying mutual inductances. To simplify the problem solution, any

three phase induction motor can be represented by an equivalent two phase motor, where  $d^s - q^s$ , are stators direct and quadrature axes as well as  $d^r - q^r$ , are rotor direct and quadrature axes.

Time-varying inductances in the voltage equations of an induction motor also can be eliminated by transforming rotor variables to variables associated with fictitious stationary windings. In this case, the rotor variables are transformed to a stationary reference frame fixed to the stator.

The paper presents a mathematical model of the induction motor in a stationary reference frame. A mathematical model of the linear induction motor in stationary reference frame  $\alpha, \beta$  developed for the linear motor is presented in [5]. For revolving induction motor it can be written as (1):

$$\begin{cases} u_{ds}^s = \left[ \left( \frac{1}{L_s} + \frac{L_m k_1}{L_s L_r} \right) \cdot \psi_{ds}^s - \frac{L_m}{L_s L_r} \cdot \psi_{ds}^r \right] \cdot R_s + \frac{d\psi_{ds}^s}{dt}; \\ u_{qs}^s = \left[ \left( \frac{1}{L_s} + \frac{L_m k_1}{L_s L_r} \right) \cdot \psi_{qs}^s - \frac{L_m}{L_s L_r} \cdot \psi_{qs}^r \right] \cdot R_s + \frac{d\psi_{qs}^s}{dt}; \\ u_{ds}^r = \left[ \frac{1}{L_r} \left( \psi_{ds}^r - k_1 \cdot \psi_{ds}^s \right) \right] \cdot R_r + \frac{d\psi_{ds}^r}{dt} + \omega_r \cdot \psi_{qs}^r; \\ u_{qs}^r = \left[ \frac{1}{L_r} \left( \psi_{qs}^r - k_1 \cdot \psi_{qs}^s \right) \right] \cdot R_r + \frac{d\psi_{qs}^r}{dt} + \omega_r \cdot \psi_{ds}^r. \end{cases} \quad (1)$$

Detailed description of modelling of AC induction motor in stationary reference frame can be found in [6].

To realize an advanced  $U/f$  control, an auto-boost voltage method to compensate the voltage drop across the stator leakage impedance is proposed. Then:

$$U = U_0 + K \cdot f_p, \quad (2)$$

where  $U$  – stator voltage.

In this case critical slip increases significantly with  $f_p$  reduction while the critical torque is only slightly decreased when  $f_p$  decreases at frequencies above 5 Hz. Below this value the peak torque decreases dramatically. For a safe start  $U = U_0 + K \cdot f_p$ , is applied to compensate the stator resistance drop  $R_s, I_s$

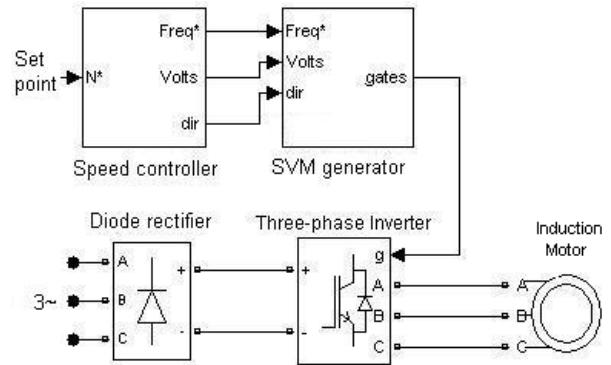
$$U_0 = R_s I_s, \quad (3)$$

$U_0$  is called the voltage boost and amounts to a 5% percent of rated voltage  $U$  higher for low power motors. The motor model has been realized using the actual parameters of the induction motor presented in the Table 1.

**Table 1.** Parameters of the modelled induction motor

Parameter	Units	Value
U	[V]	380
P	[kW]	4
I	[A]	7,7
n	[rpm]	3000
T	[N · m]	13,22
$R_s$	[ $\Omega$ ]	1,55
$L_s$	[mH]	5,2
$R_r$	[ $\Omega$ ]	1,04
$L_r$	[mH]	9,3

Designed model presented in Fig. 2 consist of speed controller with ramp and voltage boost function, space vector modulation generator, diode rectifiers, three phase inverters and induction motor.



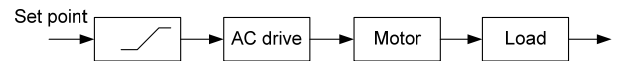
**Fig. 2.** Structure of Simulink model of variable speed drive

The developed model of the induction motor can be used with various motor parameters in order to analyze different transients in the motor with desired load on the shaft [8].

### Simulation results of open-loop mechatronic system

Usually, a constant  $U/f$  drive is not used for high-performance applications and its dynamic response is not of primary concern; however, all drives should exhibit a reasonable dynamic response and avoid instability problems.

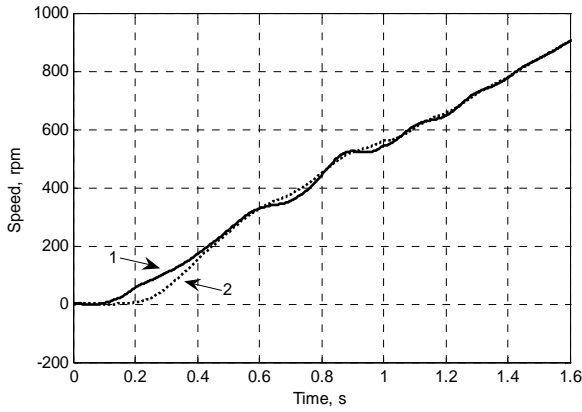
The effectiveness of the stator resistance compensation algorithm was evaluated by measuring the resultant torque and speed characteristics at different frequencies. Because the presented technique is developed to enhance the operation at low speed region, the responses of drive are analyzed at speed around 100 rpm.



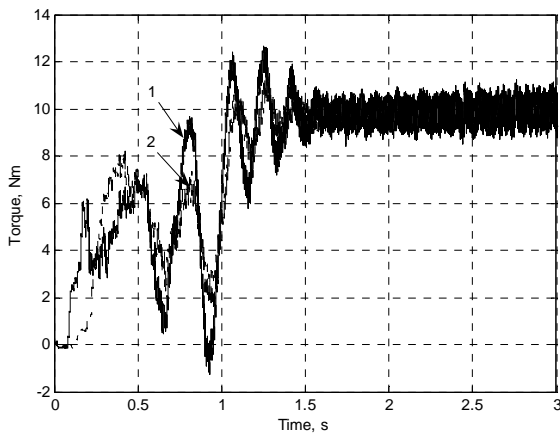
**Fig. 3.** Structure of open loop mechatronics system

Open-loop mechatronics system with different static loads  $T = 5 \text{ N}\cdot\text{m}$ ,  $3 \text{ N}\cdot\text{m}$ ,  $1 \text{ N}\cdot\text{m}$  and different phase frequencies  $f_p = 50 \text{ Hz}$ ,  $30 \text{ Hz}$ ,  $10 \text{ Hz}$  are applied to the motor shaft after 1 sec., after the start up are simulated. System has an acceleration of 600 rpm/s, that means that speed reference equal to rated speed is reached in 5 sec., this is mostly the case in different applications. Different manufactures of ac drives allowing changing the ramp to different values (0.1 – 600 sec.) depending on application.

Simulation results showing the response of torque change with a 5 N·m load at 50 Hz and to a ramp speed command are presented in Figs. 4 and 5. In the first case, the motor initially stalls after the load is applied, and after 1 s, the drive recovers and reaches the final speed with zero steady-state error. Torque response in the system with voltage boost to a ramp command shows a good dynamic behaviour (1) comparing with the system without (2) voltage boost.

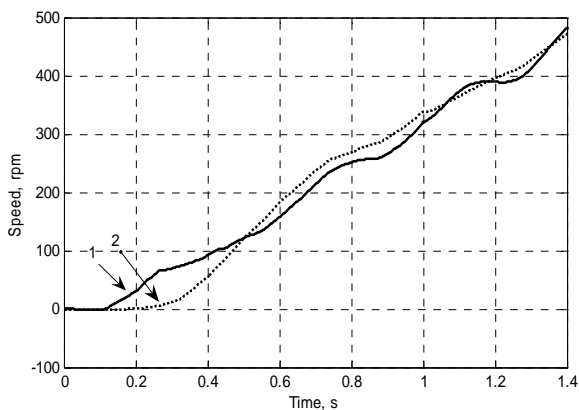


**Fig. 4.** Drive response to ramp speed reference at  $f_p = 50 \text{ Hz}$  and  $T_{load} = 5 \text{ N} \cdot \text{m}$  : 1 – with applied voltage boost, 2 – without the voltage boost



**Fig. 5.** Response of developed torque at  $f_p = 50 \text{ Hz}$  and  $T_{load} = 5 \text{ N} \cdot \text{m}$  : 1 – with applied voltage boost, 2 – without the voltage boost

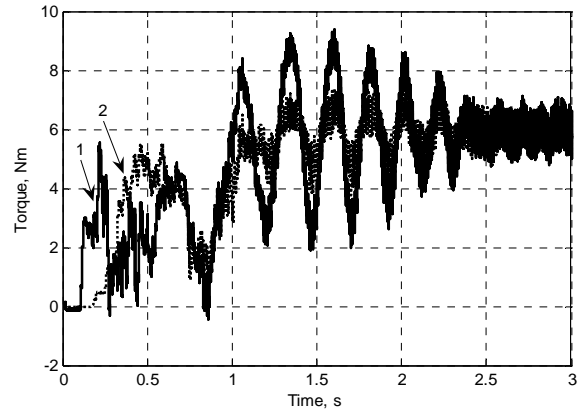
Figure 6 and 7 shows simulation results of torque change with 3 N·m load at 30 Hz and speed response command.



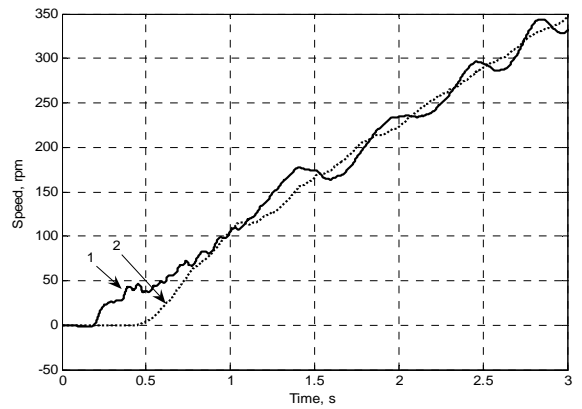
**Fig. 6.** Drive response to ramp speed reference at  $f_p = 30 \text{ Hz}$  and  $T_{load} = 3 \text{ N} \cdot \text{m}$  : 1 – with applied voltage boost, 2 – without the voltage boost

With a proposed stator resistance voltage drop compensation method the response was faster and with lower overshoot comparing with the system response without the voltage boost.

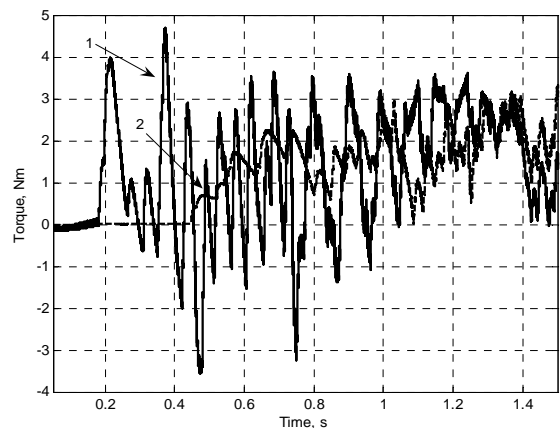
Also average torque produced by the motor in the case with the voltage boost is twice higher than in conventional  $U/f$  method at the initial of starting transients.



**Fig. 7.** Response of developed torque at  $f_p = 30 \text{ Hz}$  and  $T_{load} = 3 \text{ N} \cdot \text{m}$  : 1 – with applied voltage boost, 2 – without the voltage boost



**Fig. 8.** Drive response to ramp speed reference at  $f_p = 10 \text{ Hz}$  and  $T_{load} = 1 \text{ N} \cdot \text{m}$  : 1 – with applied voltage boost, 2 – without the voltage boost



**Fig. 9.** Response of developed torque at  $f_p = 10 \text{ Hz}$  and  $T_{load} = 1 \text{ N} \cdot \text{m}$  : 1 – with applied voltage boost, 2 – without the voltage boost

Fig. 8 and 9 shows simulation results of torque change with 1 Nm load at 10 Hz and speed response command. At this low frequency region higher ripples of

speed and torque response can be observed. However faster response to speed set point is achieved by using stator voltage compensation method.

Using the proposed stator voltage drop compensation method, the flux has constant rated level with lower ripples and current drawn from the supply. This means lower iron and copper losses, which leads to better efficiency.

## Conclusions

A novel  $U/f$  control method has been presented. Auto-boost voltage compensation for the voltage drop across stator leakage impedance are realized. When the constant  $U/f$  method is used, the motor cannot operate at very low speed. On the other hand, the proposed method can realize the speed control at very low frequency operation, from no load to the rated load. Simulation results show that good speed control accuracy can be achieved by the proposed method. This method can be easily applied to existing  $U/f$  drives. Compared to sensorless vector control system, our method does not need any PI controllers for current control, speed control and speed estimation.

## Acknowledgement

The Lithuanian State Science and Studies Foundation supported this work under High-tech development program project Nr. B/13/2008.

## References

1. **Abbondanti A.** Method of flux control in induction motors driven by variable frequency, variable voltage supplies, in Proc. IEEE-IAS Int. Semi-Annual Power Conversion Conf., 1977. – P. 177–184.
2. **Vas P.** Sensor-less Vector and Direct Torque Control // Oxford university press. – New York, 1998. P. 729.
3. **Gastli A., Matsui N.** V/f PWM inverter with motor parameter identification and voltage auto-boost capabilities. 16th Annual Conference of IEEE, 27–30 Nov 1990. – P. 903 – 908.
4. **Boldea I., Nasar S. A.** Electric Drives // Taylor&Francis, 2005. – P. 500.
5. **R. Rinkevičienė, S. Lisauskas.** Models of mechatronic systems with linear motors // Electronics and electrical engineering. Kaunas: Technologija, 2003. – Nr. 4(46). – P. 69–73.
6. **Petrovas A., Lisauskas S., Batkauskas V., Baškys A.** Variable Speed Drive Supplied by the Voltage Formed using Special-purpose Algorithm // Electronics and Electrical Engineering. – Kaunas: Technologija, 2008. – No 7(87). – P. 53–56.
7. **R. Rinkevičienė, V. Batkauskas.** Modeling and investigation of vector controlled induction drive // Electronics and Electrical Engineering. – Kaunas: Technologija, 2008. – No 1(81). – P. 53–56.

Received 2009 02 26

**R. Rinkevičienė, V. Batkauskas. Influence Of The Inverter Boost Voltage On The Transients Of Variable Speed Drive // Electronics and Electrical Engineering. – Kaunas: Technologija, 2009. – No. 4(92). – P. 75–78.**

Method and apparatus for providing adequate breakaway torque for the a-c motors started in a system in which inverter supplies electric power to the motors are presented. The output voltage of the source is substantially increased for an initial predetermined starting period to provide adequate breakaway torque, the voltage thereafter being reduced to a level corresponding to a predetermined desired constant ratio relative to output frequency. Systems with a static load with and without the starting voltage boost are analyzed. Different output frequencies are used to find out the optimal relation between voltage and frequency in scalar control method especially in low speed region. Ill. 9, bibl. 7 (in English; summaries in English, Russian and Lithuanian).

**P. Ринкявичене, В. Баткаускас. Влияние подталкивания инвертора тока на переходных процессах привода переменной скорости // Электроника и электротехника. – Каунас: Технология, 2009. – № 4(92). – С. 75–78.**

В статье приводится метод для компенсации уменьшения момента двигателя, управляемого инвертором. В начале пуска напряжение статора увеличивается для обеспечения повышенного момента. Далее напряжение снимается до постоянной величины, соответствующей частоте выходного сигнала инвертора. Приводится анализ системы с повышением напряжения статора при постоянной нагрузке и без него. Система исследована при нескольких частотах с целью найти оптимальное соотношение между напряжением и частотой. Этот вопрос особенно актуален для приводов, работающих по закону скалярного управления в режиме малых скоростей. Ил. 9, библи. 7 (на английском языке; рефераты на английском, русском и литовском яз.).

**R. Rinkevičienė, V. Batkauskas. Inverterio išėjimo įtampos padidinimo įtaka pereinamosioms kintamo greičio pavaros charakteristikoms // Elektronika ir elektrotechnika. – Kaunas: Technologija, 2009. – Nr. 4(92). – P. 75–78.**

Straipsnyje pateiktas variklio, valdomo inverteriu, momentui sumažinti taikomas kompensavimo metodas. Sukimo momento padidinimui užtikrinti asinchroninio variklio statoriaus įtampa padidinama pradiniu paleidimo periodu. Vėliau įtampa sumažinama iki nustatytos vertės, atitinkančios inverterio išėjimo dažnį. Analizuojama sistema su statoriaus pradinės įtampos padidinimo funkcija ir be jos, esant pastoviai veleno apkrovai. Sistema tiriama esant skirtingoms fazinio dažnio vertėms, kad būtų galima siekiant išsiaiškinti optimalų įtampos ir dažnio santykį. Tai ypač aktualu, kai pavaros valdomoms skaliariniu metodu mažų greičių zonoje. Il. 9, bibl. 7 (anglų kalba; santraukos anglų, rusų ir lietuvių k.).