

Real Time Image Processing for Object Detection

I. Mednieks, A. Skageris

Institute of Electronics and Computer Science

Dzerbenes st. 14, LV-1006 Riga, Latvia, phone: +371 7554500; e-mail: mednieks@edi.lv

Introduction

Detection of small objects over some background is an image processing topic that has been on focus of many researchers dealing with detection of moving objects in military applications, detection of abnormal formations in medical images as well as in other areas including industrial inspection. Potential of automated detection of small foreign objects in various industrial products is increasing significantly during the last years with the enhancement of speed and resolution parameters of the new X-ray detectors. X-ray image line scanners are mainly used for development of high speed industrial inspection systems. For example, digital X-ray camera SCAN300TDL, made by company AJAT Oy [1], placed across the conveyor apron, may collect image lines with resolution 0.1 mm and maximum conveyor speed of 50 cm/s. With such growth of the system speed and resolution, volume of digital data to be acquired and analysed in real time is increased substantially. For example, digital image of the controlled object with size 30 cm x 50 cm, acquired using the X-ray camera mentioned above, would consist of 3000 x 5000 pixels and, to exploit the maximum speed of the camera, it should be analysed in one second to meet the real time requirements.

Most of the pattern recognition methods for foreign object detection [2] are rather complicated and difficult to implement in real time industrial inspection systems exploiting maximum resolution and speed of the modern X-ray detectors. These methods and their hardware implementations usually are based on analysis of the whole acquired and buffered digital image [3, 4, 5] and are capable to detect only foreign objects of predicted size or shape. Most of those solutions are too sophisticated to implement them in fast production line systems using high resolution imaging and related algorithms are not suitable for effective implementation on the basis of very-large-scale integration circuits. It limits adoption of the new detector technology as developers of fast conveyor systems usually exploit lower resolution detectors.

Attempts to solve this problem are sought worldwide both in area of image background filtering and analysis of neighboring image pixels. For example, new ideas have been proposed in the areas of mean, median and

morphological filtering [6], new image processing methods based on regression models [7] and calculation of covariance features [8] have been designed. One of the possible ways to solve this problem is described in this paper, based on solution presented in [9] and using background filtering, thresholding and simultaneous analysis of neighboring pixels from several binary image lines. A device for detection of small foreign bodies in controllable objects exploiting this approach is proposed here, oriented towards implementation on the basis of programmable logic technologies including PLD and FPGA.

Processing approach

For the considered grayscale image processing cases, digital images are represented by matrices of integer numbers $A = (a_{ij})$ where each number corresponds to one image pixel and represents the detected brightness level of that pixel. It should be mentioned that acquisition of digital images is influenced by random factors that introduce additive noise in these values with zero mean and a definite variance depending on the characteristics of the X-ray system. At the output of the X-ray detector, range of possible pixel values is related with the resolution of exploited analog-to-digital converter (ADC). Fig. 1 illustrates such processing task. Raw image at the output of the detector is presented there; small darker regions are related with foreign bodies to be detected while the varying background represents the image of the controlled object.

Usually X-ray imaging systems do not provide linear response to linear changes of the object's thickness. For proper detection of foreign body in every location of the background related with controlled object, linearization of the system's response is needed. In addition, range of pixel values produced by different detectors is different from case to case and it is feasible to normalize it (transfer to different range of values convenient for processing) before further actions.

Fig. 2 illustrates results obtained after the linearization was performed. It is noticed that the range of pixel values is narrowed and foreign objects are equally well observed in regions with different background intensity.

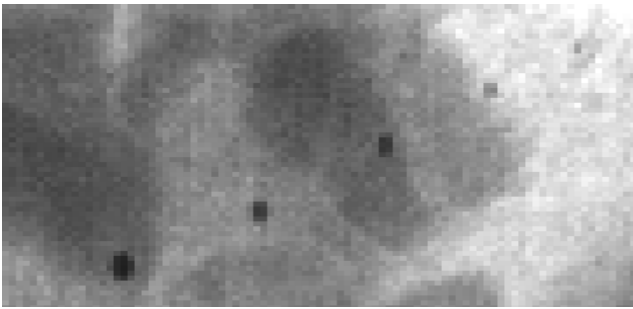

Fig. 1. Raw X-ray image fragment of the food package with foreign bodies attached for testing

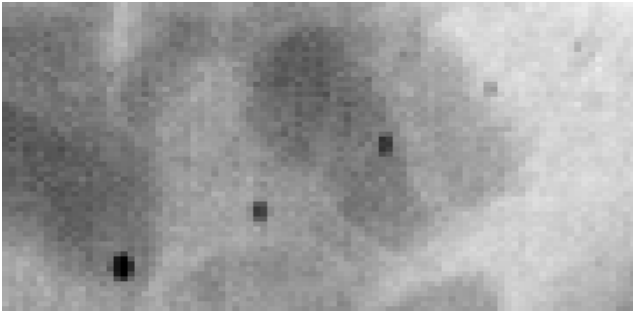

Fig. 2. X-ray image fragment after linearization

The next proposed step for analysis of X-ray scanner data is image background compensation in line profiles. This operation is used for extraction of small darker regions of image which may be recognized as possible foreign objects in the product under inspection. One of the common ways to perform this operation is using a so-called anti-median filter. In this filter, background trend of the image line is obtained pixel by pixel by applying median filter to the neighboring values of this pixel, and then the background line is subtracted from the original one. In this way slow changes of grey background levels in the image line are eliminated and only the fast brightness changes related to small objects are retained. Length of the median filter (number of neighboring pixels used to calculate the median value) must exceed doubled size of the largest object to be detected as a foreign body. Fig. 3 illustrates modeling results obtained after the background compensation by filtering horizontal lines. It is noticed that the image background is neutralized and foreign objects are accented.

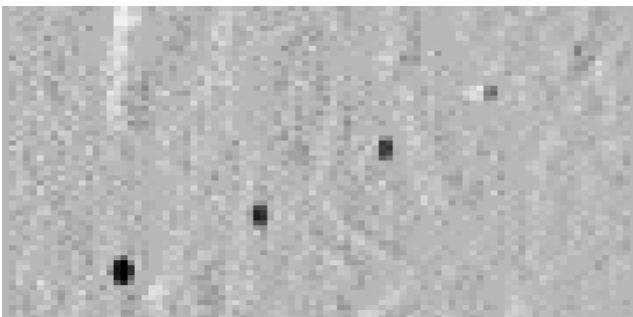

Fig. 3. X-ray image fragment after background compensation over horizontal lines using the anti-median filter with length 9

The following step is thresholding performed by comparing each output code of the anti-median filter with the certain threshold value. Threshold value has to be

calculated in advance from the available samples of objects without foreign bodies. Threshold is set to a value less than the minimum pixel value obtained within all images of such objects after the background compensation. During the actual image analysis of the controlled objects without prior knowledge about their contents, thresholding produces a binary image indicating presence of pixels in these images with values less than the calculated threshold.

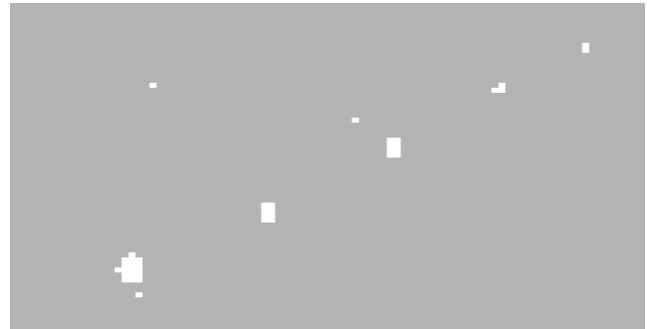

Fig. 4. X-ray image fragment after thresholding

Fig. 4 illustrates binary image obtained after the thresholding was performed. Due to the hardware noise in pixel values obtained at the output of the detector, some "false positive" pixels are obtained and additional analysis of several neighboring pixels has to be performed for reliable detection of the foreign body. Acquired binary data from L image lines (at least 2 or 3) are stored in memory, content of which is changing and corresponding to the last L lines of the binary image obtained from the X-ray scanner. Additional analysis of neighboring pixels in square region of $L \times L$ pixels is performed and decision about the presence of the foreign body made only if the sufficient amount of neighboring binary pixels in this area hold the value "1". When such decision is made, robust alarm signal is generated.

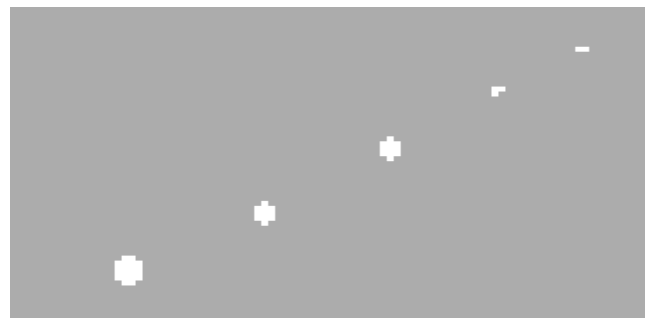

Fig. 5. X-ray image fragment after the connectivity analysis

Fig. 5 illustrates modeling results obtained after the connectivity analysis. Here, the analysis of 2×2 pixel blocks was performed and positive decision about the presence of foreign body made if more than one pixel in such neighborhood in the binary image obtained after thresholding was equal to "1". It is noticed that binary image is filtered and "false positive" pixels are removed.

Structure of the proposed device

Structure of the proposed device is presented in Fig. 6. Image data appearing at its input (0) pixel by pixel and

coupled with the pixel clock signal (5) are transformed in the linearization/normalization unit (1), processed in the anti-median filter (2) for background compensation and then presented to the code comparator (3) where pixel values are compared with the chosen threshold (4) and binary image pixel values (10) are obtained. These values are stored in memory (8) for several last lines of the image. Pixel values of the current line together with neighbouring ones of the previous lines are presented to the alarm unit (9) where the decision about the presence of the foreign object in the input image is made. Implementation and operation of the individual blocks is explained below.

Linearization-normalization unit. The easiest way to implement these operations is conversion of X-ray scanner data pixel by pixel using the programmable look-up-table (LUT) which can be adjusted to different types of detectors and parameters of the X-ray source using the experimental data obtained by processing an image of the homogenous object with linearly changing thickness. Simple realization of this unit is possible using the memory unit, where original pixel parallel code is connected to LSB address bits, and MSB part of address can be used for switching between several tables prepared for different hardware parameters. This unit does not need any clock signals.

Background filter. Major concern in development of this filter is its speed of operation. Each pixel data must be processed within one pixel clock period. For example, if conveyor speed is 500 mm/s, apron width ~4000 mm and pixel size 0.1mm x 0.1 mm, then every image line has 4K pixels, line clock frequency must be at least 5 kHz and pixel clock frequency must be at least 20 MHz. So every pixel data must be filtered in time interval less than 50 ns.

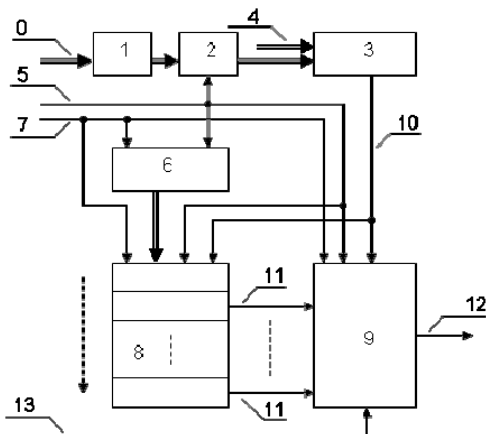

Fig. 6. Structure of the proposed device: 0 – input pixel code; 1 – linearization/normalization unit; 2 – anti-median filter; 3 – code comparator; 4 – threshold code; 5 – pixel clock; 6 – pixel counter; 7 – image line clock; 8 – binary image memory; 9 – alarm unit; 10 – binary pixel; 11 – memory outputs; 12 – alarm output; 13 – alarm reset signal

Different filters for background compensation can be exploited, however only anti-median filter is considered here. It would consist of the median filter and an algebraic adder for subtraction of the median filter output code from pixel code at the filter input. Median filter will have pixel data at its input, coupled with the pixel clock signal that can be used to form internal synchronization signals. It will contain a register for collecting N pixel values (N is the

length of the filter) from which the median value is calculated. Various implementations of median filters are described in scientific literature and patents, most adequate for real-time operation are proposed in [10, 11]. Fast implementations use symmetric register structures relative to the pixel under analysis and keep the pixel values sorted in the register, so that the output median value is available from the middle of the register. For this purpose N must be an odd number.

Code comparator. This unit produces binary digit for each pixel of the processed image at the output of the background filter by comparing its code with the threshold value (4): "0", if brightness of the pixel is greater than the threshold, and "1", if brightness of pixel is equal or lower than the threshold, "1"-es are indicating possible presence of the foreign body.

Storage of L lines of the binary image. Memory unit (8) is used for this purpose with the structure described below. It contains a separate register for storing binary pixel data of each image line considered in connectivity analysis. Each register has one input (10) and one output (11) wire and m address bits related with number of pixels M in image line. For example, if $M=4096$, then $m=12$. Besides, there is an m -bit binary address counter, which counts up pixels in every image line by pixel clock signal (5) and is reset to 0 by the line clock signal LCS (7). Parallel code of this counter is used as the address code for registers mentioned above. All these registers are mutually connected in the way that simultaneous parallel shifting is possible of all information written in the first register to the second register, from the second register to the third register, etc., initiated by the LCS. Binary pixel data (10) of the new image line are written to the first register, but outputs of other registers (11) are connected to the corresponding inputs of the alarm unit. After each data shift by LCS, the first register is cleared for writing of the next image line pixel data, but data from the last memory register are deleted.

Connectivity analysis and alarm generation. Analysis of "dark" pixel mutual disposition in the neighborhood of $L \times L$ pixels and decision to generate an alarm is made by the alarm unit (9).

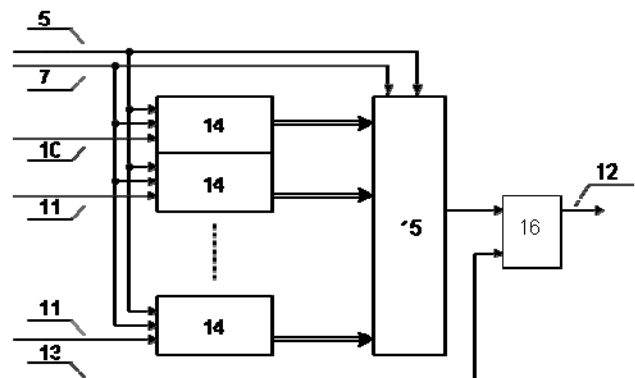

Fig. 7. Structure of the alarm unit: 14 – shift registers; 15 – programmable look-up-table; 16 – alarm trigger

Proposed structure of this unit is detailed in Fig. 7. It consists of L shift registers, each L bits long, programmable digital matrix (15) for analyzing $L \times L$ bits,

and alarm output trigger. The unit is controlled by the pixel clock (5), line clock (7) and an external alarm acknowledgement (13) signals.

Input of the first shift register is connected to the code comparator output (10), but inputs of other shift registers are connected to outputs of corresponding memory registers. All code outputs of the shift registers are connected to inputs of programmable digital matrix. This matrix is programmed to produce "1"-es at the output, if a certain number or combinations of "1"-es are present at its inputs, reflecting presence of several neighboring "dark" pixels in the currently processed region of $L \times L$ pixels. In this case, alarm trigger (16) is switched on with the next pixel clock signal (5) and alarm output signal (12) is generated until the alarm trigger is reset by the external acknowledgement signal (13).

Discussion

Image processing approach and object detection device described above have the following highlights:

1. All involved digital image processing operations can be executed within one pixel clock period so that the proposed device is suitable for implementation of systems operating in real time mode.

2. Foreign objects in inspected products can be detected using data from only few stored lines of the binary image so that the memory requirements of the device are kept to minimum.

3. Proposed structure of the object detection device can be implemented on the basis of very-large-scale integrated circuits, including PLD and FPGA, so it provides means for very fast image processing and can be realized in hardware featuring small size and very low energy consumption.

References

1. http://www.ajat.fi/products_scan.php
2. **Marques de Sa J. P.** Pattern recognition: concepts, methods and applications. Springer, Portugal. – 2001.
3. **Herley C. E.** Detecting multiple objects in digital image data. Patent US 7,058,224 B2, Jun. 6, 2006.
4. **Ikeda H.** Object detecting apparatus, method for detecting an object, and object detection program. Patent application US 2007 / 0280540 A1, Dec. 6, 2007.
5. **Basterrechea J. M. C., Kaltschmidt R.** Medical system comprising a detection device for detecting an object and comprising a storage device and method thereof. Patent application US 2008 / 0177176 A1, Jul. 24, 2008.
6. **Warren R. C.** The performance of small support spatial and temporal filters for dim point target detection in IR image sequences. <http://www.dsto.defence.gov.au/corporate/reports/DSTO-TR-1282.pdf>
7. **Lorencs A., Mednieks I., Sinica-Sinavskis J.** Biomedical image processing based on regression models. NBC-Nordic-Baltic Conference on Biomedical Engineering and Medical Physics, Riga, IFMBE Proceedings. – 2008. – Vol. 20. – P. 536–539.
8. **Mednieks I.** Object detection in grayscale images based on covariance features. Proceedings of ICSES 2008, Krakow. – 2008. – P. 205–209.
9. **Mednieks I., Skageris A.** Digital X-ray image analyzer for real-time detection of foreign bodies. Latvian patent Nr.13857, publ.20.01.2009.
10. **Sung-Wook Yoon.** Median filtering method and apparatus using plurality of processing elements. US patent, May 4, 1999.
11. **Huang S.** Method and hardware apparatus for implementing an N-sample median filter. US patent 6,078,213, Jun. 20, 2000.

Received 2009 02 10

I. Mednieks, A. Skageris. Real Time Image Processing for Object Detection // Electronics and Electrical Engineering. – Kaunas: Technologija, 2009. – No. 4(92). – P. 33–36.

A device implementing fast processing of grayscale images is described, capable of detecting small foreign bodies in images of controlled objects and proposed for industrial inspection (e.g. of food products) systems exploiting modern image detectors featuring high resolution and scanning speed. Exploited methods and structure of the device are optimized for use in real time mode and suitable for implementation on the basis of FPGA technology. Ill. 7, bibl. 11 (in English; summaries in English, Russian and Lithuanian).

И. Медникс, А. Скагерис. Обработка изображений в реальном времени для обнаружения объектов // Электроника и электротехника. – Каунас: Технология, 2009. – № 4(92). – С. 33–36.

Рассмотрены методы и устройство для скоростной обработки черно-белых изображений, позволяющие найти мелкие посторонние предметы в контролируемых объектах и предназначенные для систем промышленного контроля (например, продовольственных продуктов), использующих современные детекторы изображения, имеющие высокое разрешение и большую скорость сканирования. Исползованные методы и структура устройства оптимизированы для работы в реальном времени и приемлемы для реализации на базе ПЛИС (FPGA или PLD). Ил. 7, библи. 11 (на английском языке; рефераты на английском, русском и литовском яз.).

I. Mednieks, A. Skageris. Vaizdų apdorojimas objektams aptikti realiu laiku // Elektronika ir elektrotechnika. – Kaunas: Technologija, 2009. – Nr. 4(92). – P. 33–36.

Išanalizuoti nespaltotų vaizdų apdorojimo metodai ir įranga, leidžiantys aptikti nedidelius pašalinius objektus kontroliuojamuose objektuose, kurie skirti pramoninėms kontrolės sistemoms (pvz., maisto). Šiuolaikiniuose inžineriniuose naudojami modernūs didelės raiškos ir didelio nuskaitymo greičio detektoriai. Iširti metodai ir prietaisai yra suderinti dirbti realiu laiku ir tinkami naudoti pagal FPGA technologiją. Il. 7, bibl. 11 (anglų kalba; santraukos anglų, rusų ir lietuvių k.).