

Novel Phase-Locked Loop Using Adaptive Notch Filter

Lin Xu¹, Yang Han^{1,2}, Li-Dan Zhou¹, Gang Yao¹, Mansoor¹, Chen Chen¹, Junmin Pan¹

¹Department of Electrical Engineering, Shanghai JiaoTong University

DongChuan Road #800, Shanghai, P. R. China, phone: +086 21 62932367, e-mail: hanyang_facts@hotmail.com

²School of Mechatronics Engineering, University of Electronic Science and Technology of China

North JianShe Road, #2-4, Chengdu, P. R. China.

Introduction

Accurate phase detection of utility voltages is the most critical factor to control the power converters for custom power applications. The reference signal generated by a phase-locked loop (PLL) affects the performance of custom power devices for compensating power factor, harmonic current, and voltage disturbances. Specifically, the amplitude and phase angle of the positive-sequence component must be fast and accurately obtained, even if the utility voltage is distorted and unbalanced.

Recently, there has been increased interest in PLL topologies for grid-connected system. The three-phase PLL discussed in [1] is based on a synchronous reference frame (SRF) to detect the phase angle, frequency and amplitude of the utility voltage, which gives satisfactory performance under ideal input conditions but causes large oscillations in unbalanced and distorted conditions. A novel decoupled double synchronous reference frame phase-locked loop (DDSRF-PLL) was proposed in [2], which is achieved by transforming both positive-sequence and negative-sequence components of the utility voltages into the double reference frame, and shows excellent performance even in case of unbalanced utility voltages. Another three-phase PLL was presented in [3], which is based on a conventional three-phase PLL followed by a proportional-integral controlled moving average filter. This PLL gives fast, accurate angular frequency and phase-locking and is robust to numerous utility distortion conditions.

This paper investigates a novel three-phase PLL which is capable of locking to the phase and frequency of three-phase ac supply voltage under distorted conditions, which is based on the conventional PLL structure followed by an adaptive notch filter (ANF) and proportional-integral (PI) controller. The excellent performance of the presented PLL is validated by extensive simulation results and a detailed comparison with the conventional PLL, which has overwhelming advantages in terms of dynamic response, high accuracy in phase tracking and enhanced robustness

under various grid voltage disturbances such as voltage sag, harmonics, unbalance.

Conventional three-phase PLL

The conventional three-phase phase-locked-loop (CPLL) topology is illustrated in Fig.1. The three-phase voltage vector is transformed from abc natural reference frame to the dq rotating reference frame by using Clark's transformation and Park's transformation. The angular position of this dq reference frame is controlled by a feedback loop which regulates the q component to zero. Therefore in steady-state, the d component depicts the voltage vector amplitude and its phase is determined by the output of the feedback loop. It has been shown that the performance of CPLL is significantly degraded in presence of even slight disturbance [2].

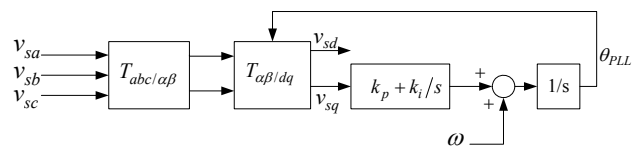

Fig. 1. Block diagram of the conventional PLL

Proposed three-phase PLL

In order to introduce the structure of three-phase PLL, some mathematical analysis will be presented. It is assumed that the utility voltages are composed of generic harmonic components and represented as:

$$\begin{cases} v_{sa}(t) = V_s^{+1} \cos(\omega t + \varphi^{+1}) + \sum_{m=-1, \dots, \pm N} V_s^m \cos(m\omega t + \varphi^m), \\ v_{sb}(t) = V_s^{+1} \cos(\omega t - \frac{2\pi}{3} + \varphi^{+1}) + \sum_{m=-1, \dots, \pm N} V_s^m \cos(m\omega t - \frac{2\pi}{3} + \varphi^m), \\ v_{sc}(t) = V_s^{+1} \cos(\omega t + \frac{2\pi}{3} + \varphi^{+1}) + \sum_{m=-1, \dots, \pm N} V_s^m \cos(m\omega t + \frac{2\pi}{3} + \varphi^m), \end{cases} \quad (1)$$

where m can be either positive or negative with ω the fundamental utility frequency; φ^{+1} and φ^m – the initial

phase angle of the fundamental; m th order component, respectively, which can be expressed as:

$$\varphi^{+1} = \theta_1 + \Delta\theta_1, \varphi^m = m\varphi^{+1} + \Delta\theta_m, \quad (2)$$

where θ_1 and $\Delta\theta_1$ represent the estimated phase angle of the fundamental component of grid voltage and the estimation error, respectively, obtained from PLL, and the phase angle of the m th order harmonic component; φ^m – derived in terms of the phase angle of the fundamental grid voltage and the error signal $\Delta\theta_m$.

Hence the three-phase grid voltages can be transformed to the stationary α - β frame by using Clark's transformation, as:

$$\begin{bmatrix} v_{S\alpha} \\ v_{S\beta} \end{bmatrix} = \begin{bmatrix} V_S^{+1} \cos(\omega t + \varphi^{+1}) + \sum_{m=-1, \dots, \pm N} V_S^m \cos(m\omega t + \varphi^m) \\ V_S^{+1} \sin(\omega t + \varphi^{+1}) + \sum_{m=-1, \dots, \pm N} V_S^m \sin(m\omega t + \varphi^m) \end{bmatrix}. \quad (3)$$

The obtained quantities are transformed into synchronous rotating reference frame by using Park's transformation:

$$v_{S(dq^{+1})} = T_{\alpha\beta/dq} v_{S\alpha\beta}, \quad (4)$$

where $T_{\alpha\beta/dq} = \begin{bmatrix} \cos\theta_{PLL} & \sin\theta_{PLL} \\ -\sin\theta_{PLL} & \cos\theta_{PLL} \end{bmatrix}$; θ_{PLL} – the phase

angle detected by PLL. The q -axis voltage $v_{Sq^{+1}}$ can be derived as:

$$v_{Sq^{+1}} = V_S^{+1} \sin(\omega t + \varphi^{+1} - \theta_{PLL}) + \sum_{m=-1, \dots, \pm N} V_S^m \sin(m\omega t + \varphi^m - \theta_{PLL}). \quad (5)$$

If a perfect synchronization of the PLL is possible, which means $\theta_{PLL} = \omega t + \theta_1$. Substituting Eq. (2) into Eq. (5), rearranging terms, the following Equation can be got :

$$\begin{aligned} v_{Sq^{+1}} &= V_S^{+1} \sin(\Delta\theta_1) + \sum_{m=-1, \dots, \pm N} V_S^m \sin(m\omega t + \varphi^m - \omega t - \theta_1) = \\ &= V_S^{+1} \sin(\Delta\theta_1) + \sum_{m=-1, \dots, \pm N} V_S^m \sin[(m-1)(\omega t + \theta_1) + \varphi^m - m\theta_1] = \\ &= V_S^{+1} \sin(\Delta\theta_1) + \sum_{m=-1, \dots, \pm N} V_S^m \sin[(m-1)(\omega t + \theta_1) + m\Delta\theta_1 + (\varphi^m - m\varphi^{+1})] = \\ &= V_S^{+1} \sin(\Delta\theta_1) + \sum_{m=-1, \dots, \pm N} V_S^m \cos[m\Delta\theta_1 + (\varphi^m - m\varphi^{+1})] \sin[(m-1)(\omega t + \theta_1)] + \\ &+ \sum_{m=-1, \dots, \pm N} V_S^m \sin[m\Delta\theta_1 + (\varphi^m - m\varphi^{+1})] \cos[(m-1)(\omega t + \theta_1)]. \end{aligned} \quad (6)$$

Equation (6) suggests that the original signal $v_{Sq^{+1}}$ can be regenerated by adjusting the coefficients $V_S^{+1} \sin(\Delta\theta_1)$, $V_S^m \cos[m\Delta\theta_1 + (\varphi^m - m\varphi^{+1})]$, $V_S^m \sin[m\Delta\theta_1 + (\varphi^m - m\varphi^{+1})]$, ($m=-1, \pm 2, \dots, \pm N$), even though the phase angle of the original signal is unknown. The objective of the proposed PLL is to reconstruct the phase information of the fundamental grid voltage angle using least-mean-square (LMS) algorithm [4]. Applying this algorithm, Eq. (6) can be expressed as:

$$\hat{Y} = WX, \quad (7)$$

where \hat{Y} – the estimated value of signal $v_{Sq^{+1}}$. The vector W and X correspond to the weight vector and the input vector for the signal, respectively, are represented as:

$$W = [V_S^{+1} \sin(\Delta\theta_1), \dots, V_S^m \cos(m\Delta\theta_1 + (\varphi^m - m\varphi^{+1})), V_S^m \cos(m\Delta\theta_1 + (\varphi^m - m\varphi^{+1})), \dots], \quad (8)$$

$$X = \{1, \sin[-2(\omega t + \theta_1)], \cos[-2(\omega t + \theta_1)], \dots, \sin[(m-1)(\omega t + \theta_1)], \cos[(m-1)(\omega t + \theta_1)], \dots\}^T. \quad (9)$$

In order to make adaptation of weight vector W , the following cost function is chosen:

$$J_k = (\hat{W}_{k+1} - \hat{W}_k)^H \cdot (\hat{W}_{k+1} - \hat{W}_k) + \lambda \cdot (Y_k - \hat{W}_{k+1}^H X_k) \quad (10)$$

where λ denotes the real-valued Lagrange multiplier, \hat{W}_k denotes the old weight vector at the k th iteration and \hat{W}_{k+1} denote its updated weight vector at the $(k+1)$ th iteration, Y_k – the desired output corresponding to input vector X_k , which means that for each (X_k, Y_k) pair, there exists at least one \hat{W}_{k+1} , such that the following equation is satisfied:

$$\hat{W}_{k+1}^H X_k = Y_k. \quad (11)$$

The optimum weight vector can be found by minimizing J_k , differentiate J_k with respect to \hat{W}_{k+1} , then:

$$\frac{\partial J_k}{\partial \hat{W}_{k+1}} = 2(\hat{W}_{k+1} - \hat{W}_k) - \lambda X_k. \quad (12)$$

By setting Eq. (12) to zero, the optimum value for \hat{W}_{k+1} can be got:

$$\hat{W}_{k+1} = \hat{W}_k + \frac{1}{2} \lambda X_k. \quad (13)$$

The output Y_k can be rewritten:

$$Y_k = \hat{W}_k^H X_k + \frac{1}{2} \lambda \|X_k\|^2. \quad (14)$$

Then, the Lagrange multiplier λ can be obtained as:

$$\lambda = \frac{2e_k}{\|X_k\|^2}, \quad (15)$$

where $e_k = Y_k - \hat{W}_k^H X_k$ represents the estimation error of the adaptive notch filters. From the above Eq. (13) and Eq. (15), the following equation can be derived:

$$\hat{W}_{k+1} - \hat{W}_k = \frac{1}{\|X_k\|^2} X_k e_k. \quad (16)$$

In order to ensure stable operation of the weight vector updating process, a positive real scaling factor μ is introduced to the step size. Therefore Eq. (16) can be redefined as:

$$\hat{W}_{k+1} - \hat{W}_k = \frac{\mu}{\|X_k\|^2} X_k e_k. \quad (17)$$

The selection of the step-size parameter μ is a compromise between the estimation accuracy and the convergence speed of the weights updating process. Assuming that the physical mechanism responsible for generating the desired response Y_k is controlled by the multiple regression model:

$$Y_k = \hat{W}_{k+1}^H X_k = W^H X_k + d_k, \quad (18)$$

where W represents the model's unknown parameter vector and d_k represents unknown disturbances that account for various system impairments, such as random noise, modeling errors or other unknown sources. The weight vector \hat{W}_k computed by the adaptive notch filtering algorithm is an estimate of the actual weight vector W , hence the estimation error can be presented by:

$$\varepsilon_k = W - \hat{W}_k \quad (19)$$

the incremental in the estimation error can be derived as:

$$\varepsilon_{k+1} = \varepsilon_k - \frac{\mu}{\|X_k\|^2} X_k e_k. \quad (20)$$

The object of adaptive notch filter is to minimize the incremental change in the weight vector \hat{W}_{k+1} from the k th and $k+1$ th iteration, subject to a constraint imposed on the updated weight vector \hat{W}_{k+1} . Therefore, the stability of ANF algorithm can be investigated by defining the mean-square deviation of the weight vector estimation error:

$$\rho_n = E[\|\varepsilon_k\|^2]. \quad (21)$$

Taking the squared Euclidean norms of both sides of Eq.(20), rearranging terms, and then taking the expectations on both sides of equation, we get:

$$\rho_{n+1} = \rho_n + \mu^2 E\left[\frac{|e_k|^2}{\|X_k\|^2}\right] - 2\mu E\left[\frac{\xi_k e_k}{\|X_k\|^2}\right], \quad (22)$$

where ξ_k denotes the undisturbed error signal defined by $\xi_k = (W - \hat{W}_k)^H X_k$; $X_k = \varepsilon_k^H X_k$, to realize the object of convergence, that is $\rho_{n+1} < \rho_n$, then the step-size parameter μ should satisfy the following condition:

$$0 < \mu < 2 \frac{E[\xi_k e_k / (\|X_k\|^2)]}{E[|e_k|^2 / (\|X_k\|^2)]}. \quad (23)$$

Description of the proposed three-phase PLL

Based on the adaptive notch filter methodology mentioned in the above section, a novel phase-locked loop algorithm is derived, as shown in Fig.2. For the sake of brevity, only fundamental component, fifth and seventh order harmonics are considered in the grid voltages, including positive sequence and negative sequence component, therefore the estimation blocks corresponding to these components are considered in the proposed PLL. One may extend the order of the PLL by incorporating higher order harmonic blocks in the algorithm according to the particular applications.

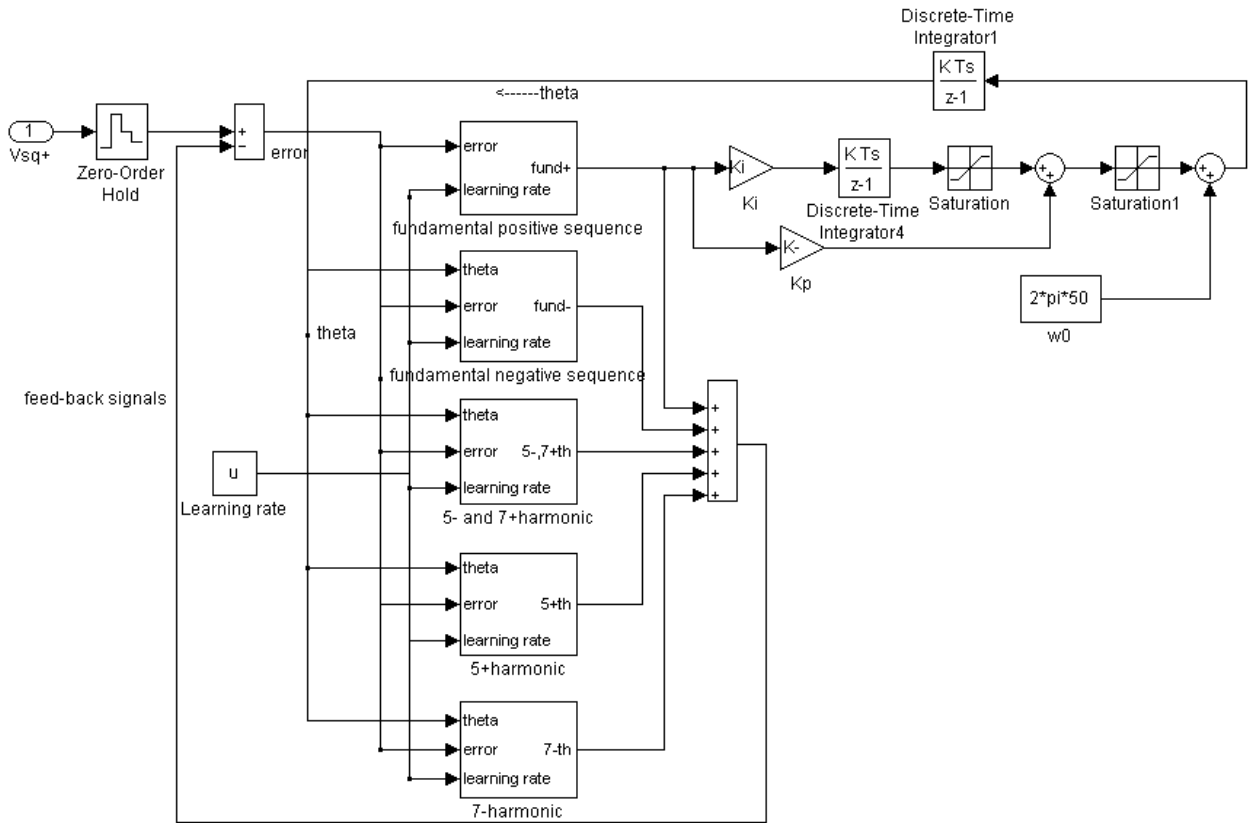

a)

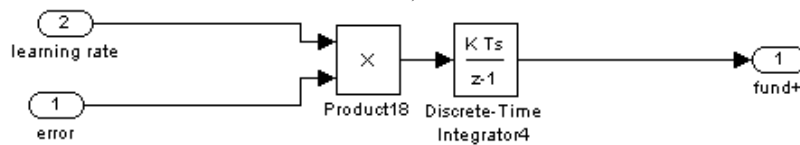

b)

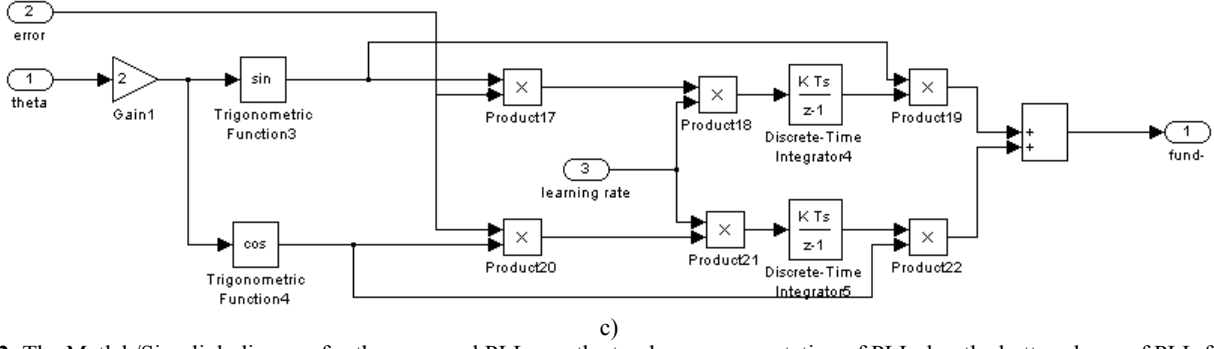

Fig. 2. The Matlab/Simulink diagram for the proposed PLL: a – the top layer representation of PLL; b – the bottom layer of PLL for the fundamental frequency – positive sequence component estimation; c – the bottom layer of PLL for fundamental frequency-positive sequence component estimation

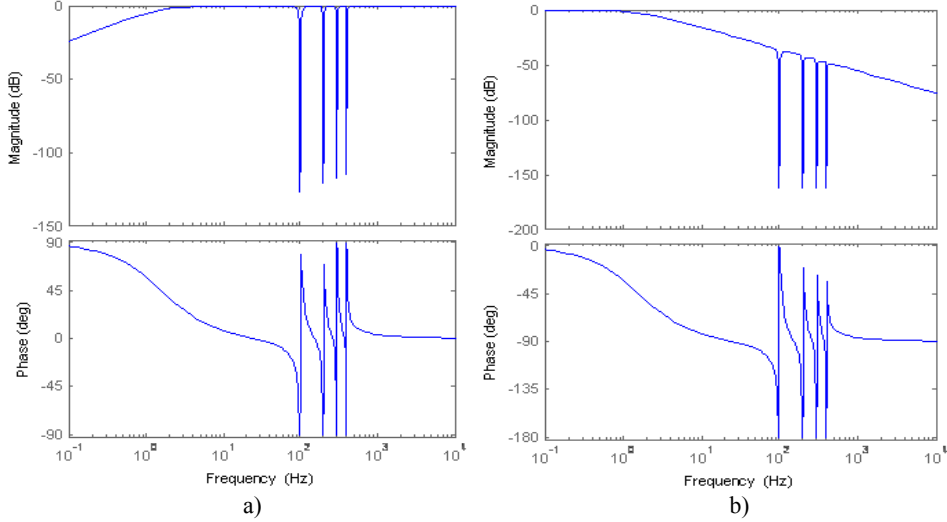

Fig. 3. Bode plot of the PLL when the fundamental frequency block, the fifth and seventh harmonic blocks are considered: a – frequency response from $v_{Sq}^{+1}(s)$ to $E(s)$; b – frequency response from $v_{Sq}^{+1}(s)$ to $v_{Sq}^{+1}(s)$

Fig.2a shows the top layer representation of the PLL, which shows the estimation error, phase angle of the fundamental component. The learning rate are utilized as the inputs to the subsystems, namely, the fundamental frequency-positive sequence block, the fundamental frequency-negative sequence block, the fifth order harmonic-negative sequence and seventh order harmonic-positive sequence block, the fifth order harmonic-positive sequence block, the seventh order harmonic-negative sequence block. However, only the weight of the fundamental frequency-positive sequence block is used for the outer loop controller, namely, the PI controller and the integrator, in a similar manner as that of the conventional three-phase PLL shown in Fig.1. Fig.2 (b)-(c) shows the two subsystems for individual component estimation, namely, the fundamental frequency -positive sequence component estimation and the fundamental frequency-negative sequence component estimation. Similarly, the following subsystems are nearly the same as the frequency-negative sequence block, just exchanging the gain “2” into “6”, “4” and “8”. The phase estimation error denoted by $V_S^{+1} \sin(\Delta\theta_1)$ can be regulated to zero by using such a properly designed closed-loop control system in incorporating the adaptive notch filter methodology, and the original signal can be regenerated.

In order to analysis characteristic of the proposed PLL, frequency domain analysis on the control block diagram will be shown on. According to the block diagram in Fig.2, the following transfer functions from estimation error $E(s)$ to the individual harmonic component output $V_{sn}(s)$ can be derived as:

$$G_1(s) = \frac{K_1}{s}, \quad G_n(s) = \frac{K_n s}{s^2 + (n\omega)^2}, \quad (24)$$

where $n=2, 4, 6, 8$. Hence the transfer function from input v_{Sq}^{+1} to E can be represented as:

$$G_{error}(s) = \frac{E(s)}{v_{Sq}^{+1}(s)} = \frac{1}{1 + G_1(s) + \sum_{n=2,4,6,8} G_n(s)}. \quad (25)$$

Similarly, the transfer function from v_{Sq}^{+1} to the estimated fundamental component $\overline{v_{Sq}^{+1}}$ can be derived as:

$$G_{fund}(s) = \frac{\overline{v_{Sq}^{+1}}(s)}{v_{Sq}^{+1}(s)} = \frac{G_1(s)}{1 + G_1(s) + \sum_{n=2,4,6,8} G_n(s)}. \quad (26)$$

Fig. 3 shows the frequency response of the PLL when the positive-sequence and negative-sequence components

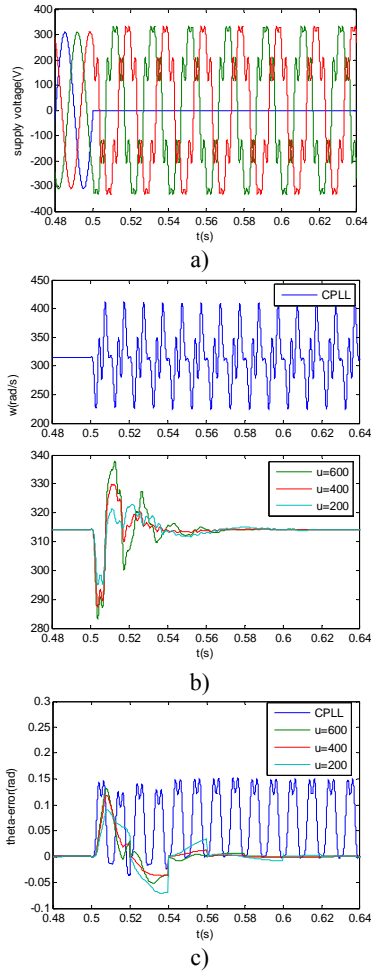

Fig. 4. Performance comparison between CPLL and the proposed PLL in case 1: a – grid voltages; b – angular frequency output; c – phase estimation error

Simulation results

To compare the operation of the conventional and proposed PLLs, simulation results are provided to study the effect of voltage distortion on both PLL outputs. Fig.4 shows the performance of both PLL when 0.2 pu 5th order negative-sequence and 0.2 pu 7th order positive-sequence harmonic components are suddenly applied to phase *b* and phase *c* of the grid voltages, meanwhile, phase *a* voltage sags to zero. The waveform of the supply voltage is shown in Fig.4a. Fig.4b and Fig.4c show the PLL output angular

frequency detection and phase detection error of both PLL respectively. It can be observed that the phase angle and angular frequency are highly distorted for the conventional PLL. For the proposed PLL, the angular frequency stabilizes in one or two ac cycles, without the large oscillations that occur with the conventional PLL, the maximum overshoot θ is nearly 0.1 rad. With different learning rate μ , the velocity of the proposed PLL convergence is quite different. In simulation results shown, the conventional PLL phase angle does not phase back like the proposed PLL.

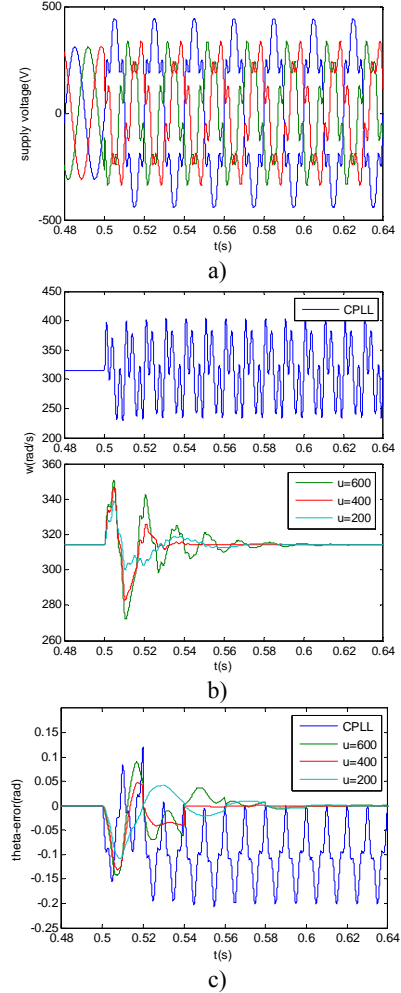

Fig. 5. Performance comparison between CPLL and the proposed PLL in case 2: a – grid voltages; b – angular frequency output; c – phase estimation error

Fig.5 shows the performance of both PLL when fundamental frequency and harmonic components are highly unbalanced and distorted, with 0.3 pu fundamental frequency negative-sequence, 0.2 pu 5th order negative-sequence, 0.1 pu 5th order positive-sequence, 0.1 pu 7th order positive-sequence, 0.1 pu 7th order negative-sequence component. The waveform of the supply voltage is shown in Fig.5a. It can be observed that the proposed PLL tracks the grid frequency in one ac supply period. However, the conventional PLL has difficulty tracking the frequency as the supply distortion and unbalance increase, as shown in Fig.5b and Fig.5c.

The simulation results shown in Fig.4 and Fig.5 verify the ability of the proposed PLL to accurately lock to the

supply angular frequency and phase in one ac supply period under line disturbances, such as sag, harmonic, unbalance, whereas the conventional PLL fails to lock accurately in the highly distorted and unbalanced grid.

Conclusions

In this paper, a novel PLL composed of an adaptive notch filter is proposed. The accuracy and robustness of the proposed algorithm is verified by the comparison between the proposed and conventional PLLs under distorted and unbalanced condition. The transient response of the proposed PLL was tested and it responds in one ac supply cycle. Supply angular frequency locking and phase angle tracking are much better than the conventional PLL schemes. The proposed PLL can be utilized as a basic control element of a power converter for active power filter (APFs), dynamic voltage restorer (DVRs) and motor drives applications.

References

1. **Zhan C., Fitzer C., Ramachandaramurthy K., Arulampalam A., Barnes M., Jenkins N.** Software phase-locked loop applied to dynamic voltage restorer // Proc IEEE-PES Winter Meeting. – 2001. – P. 1033–1038.
2. **Rodriguez P., Pou J., Bergas J.** Decoupled Double Synchronous Reference Frame PLL for Power Converters Control // IEEE Transaction on Power Electronics. – 2007. – Vol. 22, No. 2. – P. 584–592.
3. **Salamah A. M., Finney S. J., Williams B. W.** Three-phase phase-lock loop for distorted utilities // IET Electr. Power Appl. – 2007. – Vol. 1, No. 6. – P. 937–945.
4. **Widrow B., Lehr M.A.** 30 years of adaptive neural networks: perceptron, madaline, and backpropagation // Proc. IEEE – 1990. – Vol. 78, No. 9. – P. 1415–1442.

Received 2009 01 21

Lin Xu, Yang Han, Li-Dan Zhou, Gang Yao, Mansoor, Chen Chen, Junmin Pan. Novel Phase-Locked Loop Using Adaptive Notch Filter // *Electronics and Electrical Engineering*. – Kaunas: Technologija, 2009. – No. 4(92). – P. 7–12.

A novel three-phase phase-locked loop (PLL) structure suitable for phase and angular frequency tracking from distorted ac utility voltages is presented. The proposed PLL has a simple structure: a conventional three-phase PLL followed by adaptive notch filtering technique and proportional integral controller. The feasibility of the PLL was confirmed by theoretical analysis, and the performance was verified through simulations. The proposed PLL system shows accurate performance under various line voltage disturbances, such as sag, unbalance and harmonics. Ill. 5, bibl. 4 (in English; summaries in English, Russian and Lithuanian).

Лин Ху, Янг Хан, Ли-Дан Зхоу, Ганг Яо, Мансоор, Чен Чен, Юмин Пан. Использование адаптивного затворного фильтра при фазовой автоподстройке частоты // *Электроника и электротехника*. – Каунас: Технология, 2009. – № 4(92). – С. 7–12.

Анализируется новая структура трехфазной автоподстройки частоты (ФАПЧ). Предлагаемая ФАПЧ имеет простую структуру: обычную трехфазную ФАПЧ, адаптивную фильтрацию методом вырезки и пропорциональный интегральный контроллер. Целесообразность ФАПЧ подтвердили: теоретический анализ и результаты моделирования. Предлагаемая система ФАПЧ обеспечивает хорошие показатели при различных изменениях. Ил. 5, библи. 4 (на английском языке; рефераты на английском, русском и литовском яз.).

Lin Xu, Yang Han, Li-Dan Zhou, Gang Yao, Mansoor, Chen Chen, Junmin Pan. Adaptyvaus užtvarinio filtro taikymas fazinėje kilpoje // *Elektronika ir elektrotechnika*. – Kaunas: Technologija, 2009. – Nr. 4(92). – P. 7–12.

Pasiūlyta nauja trifazės fazinės kilpos (FK) struktūra. Siūloma FK turi paprastą struktūrą: įprastas tris FK su adaptuotu užtvariniu filtru ir proporcingą integralinį valdiklį. FK tinkamumą patvirtina teorinės analizės ir modeliavimo metu gauti rezultatai. Siūloma FK sistema gali dirbti esant įvairiems įtampoms sutrikimams. Il. 5, bibl. 4 (anglų kalba; santraukos anglų, rusų ir lietuvių k.).

