

Autonomous Mobile Device Controlled by On-chip Network of Intelligent Sensors for Indoor Environment Navigation

Cr. A. Tanase, A. Graur, V.G. Gaitan, V. Popa

*Department of Computers, Faculty of Electrical Engineering and Computer Science,
Stefan cel Mare University of Suceava, Romania, phone: +40-230-520277 ext. 225;
e-mails: andy_1@eed.usv.ro, adriang@eed.usv.ro, gaitan@eed.usv.ro, valentin@eed.usv.ro*

Introduction

The growing complexity of the multiprocessor on-chip systems (SoC) makes a revision of the on-chip communication techniques to be necessary. Wireless stations, TV of high definition / resolution, mobile telephony and many other devices of great complexity, are only a few applications that are developed thanks to the multiprocessor systems SoC.

In this kind of chips, the restrictions connected to the performances, the energy consumption, the reliability, cost and tolerances at errors are extremely severe. The implementation on the effective development of an on-chip network requires a whole set of dedicated devices that form the infrastructure, as well as a set of techniques and connection methods. For example, NoC requires switches, routers and communication protocols [1][2].

Within a short period of time, the implementation of the networks on the chip will be as usual as possible. Because of the complexity of SoC, these will be strictly necessary in the implementation of the communications between different devices on the chip. The basic concept is to communicate inside the chip in the same way that the messages are transmitted today over the internet.

General description

The device mainly consists of two components:

Sensorial (intelligent sensors) for searching the target and for detecting the obstacles.

The informatics system for determination of the target position, establishing the route to follow, the analysis and the control of the information taken over from the sensors.

The sensorial component is made up of a great number of sensors of different kinds, especially selected and mounted in order to obtain a quantity as great as possible of information from these. There are IR sensors to locate an IR target. The ultrasonic sensors to detect the great obstacles placed at distances over 1 meter. The optical sensors are used to avoid the collision with small obstacles and keep a certain distance from the nearby

walls. There is a Hall-effect sensor (electronic compass) for maintaining the direction.

The informatics component is carried out entirely on a FPGA programmable device. The system on-chip (SoC) that is performed is actually an internal network (NoC) of functional units that have the task to receive raw data from the sensors and to transfer them in useful information as much as possible. Every sensor has an intelligent unit of description assigned to it.

The positioning of the sensors on the mobile device is presented in the Fig. 1.

The intelligent sensors consist of sensors and the functional units dedicated and implemented in FPGA. Thanks to the great number of functional units, they are connected with each other through an internal network (Network on chip - NoC). This network shows some features, such as: a dedicated protocol, a system of switches and network interfaces, devices for detection and correction of the errors, protocols of routing the messages depending on their priorities. There is more, implemented on the chip, a main mobile for decision, according to the information received through the network from the sensors and to the fixing of the followed route.

The main problems that must be solved consist of:

- Establish the number and the kinds of necessary sensors;
- To achieve the power electronic equipment and interfacing between the sensorial and the informatics system;
- Designing the SoC architecture, the NoC architecture and determination of their features;
- Implementing the SoC architecture on the FPGA device;
- Implementing the NoC architecture on the FPGA device and performing the connections between the functional block of the SoC.

The target is an IR source, searched by an IR radar, consisting of 8 sensors placed equidistant on the circumference of a circle. In the moment of the determination of the direction of the target, the compass

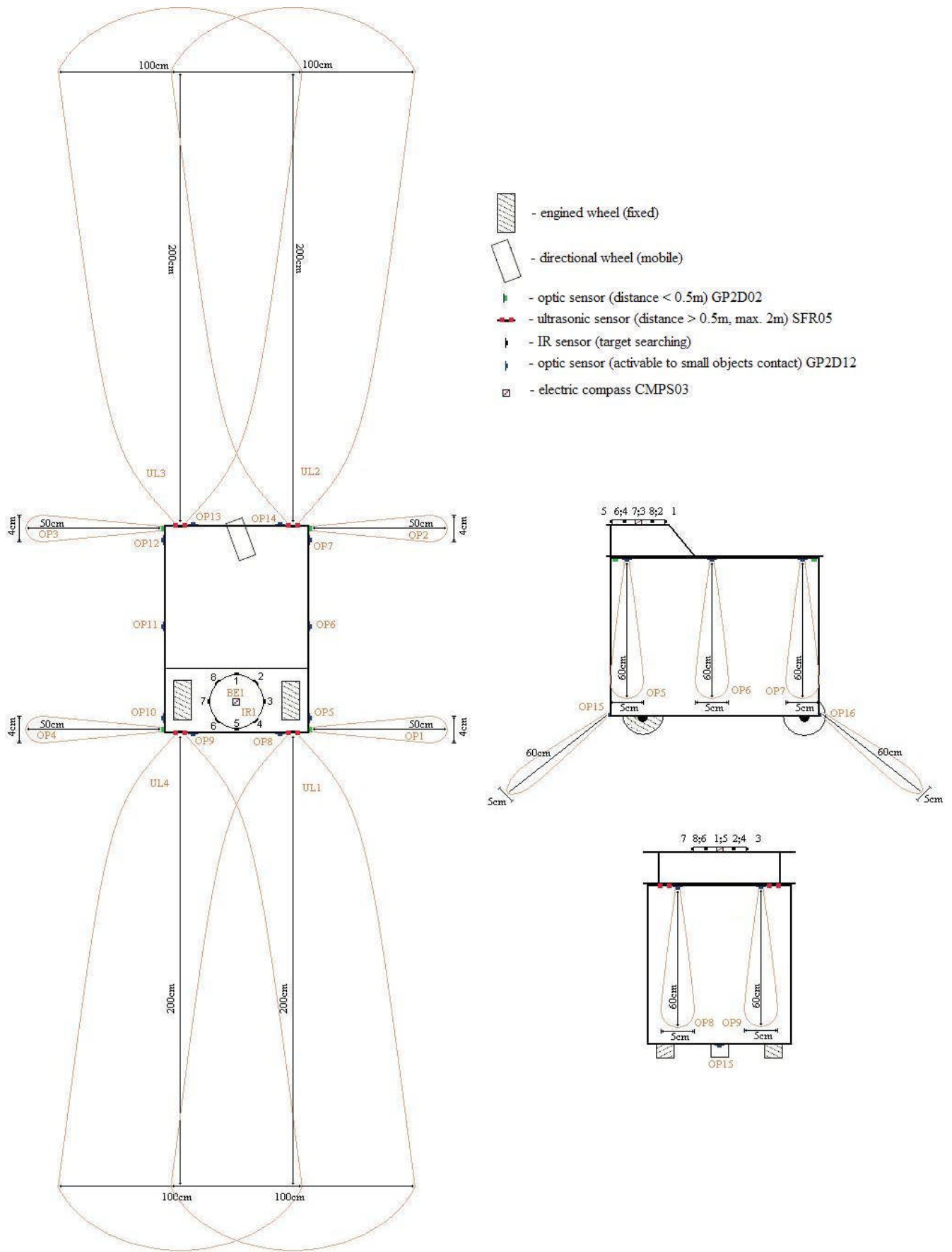

Fig. 1. The emplacement of the sensors on the mobile device

reads this direction and follows it permanently. When an obstacle appears, the algorithm of detection and avoidance of the obstacles is activated and after that the target is searched again.

The NoC architecture

Every sensor has a functional unit assigned to it, a unit that is an automat machine that links with the dedicated sensor and reads the data generated from it. These automats have some features specific for systems with intelligent sensors. They are adaptable to the environment, which means they optimize the activity of

detection and communication according to the needs of the environment. Another feature is that the data are recorded, filtered, and the result is only a useful information. The digital automats are implemented with built-in self-diagnostic functions such as for normal or abnormal work and make it to be informed about by the other sensor of the system.

The implemented NoC architecture is shown in figure 2. Every switch is connected to a resource block in which the functional unit dedicated to the sensor is implemented. These functional units are different from architectural and functional point of view. For this reason there are necessary interfacing blocks with the network [4].

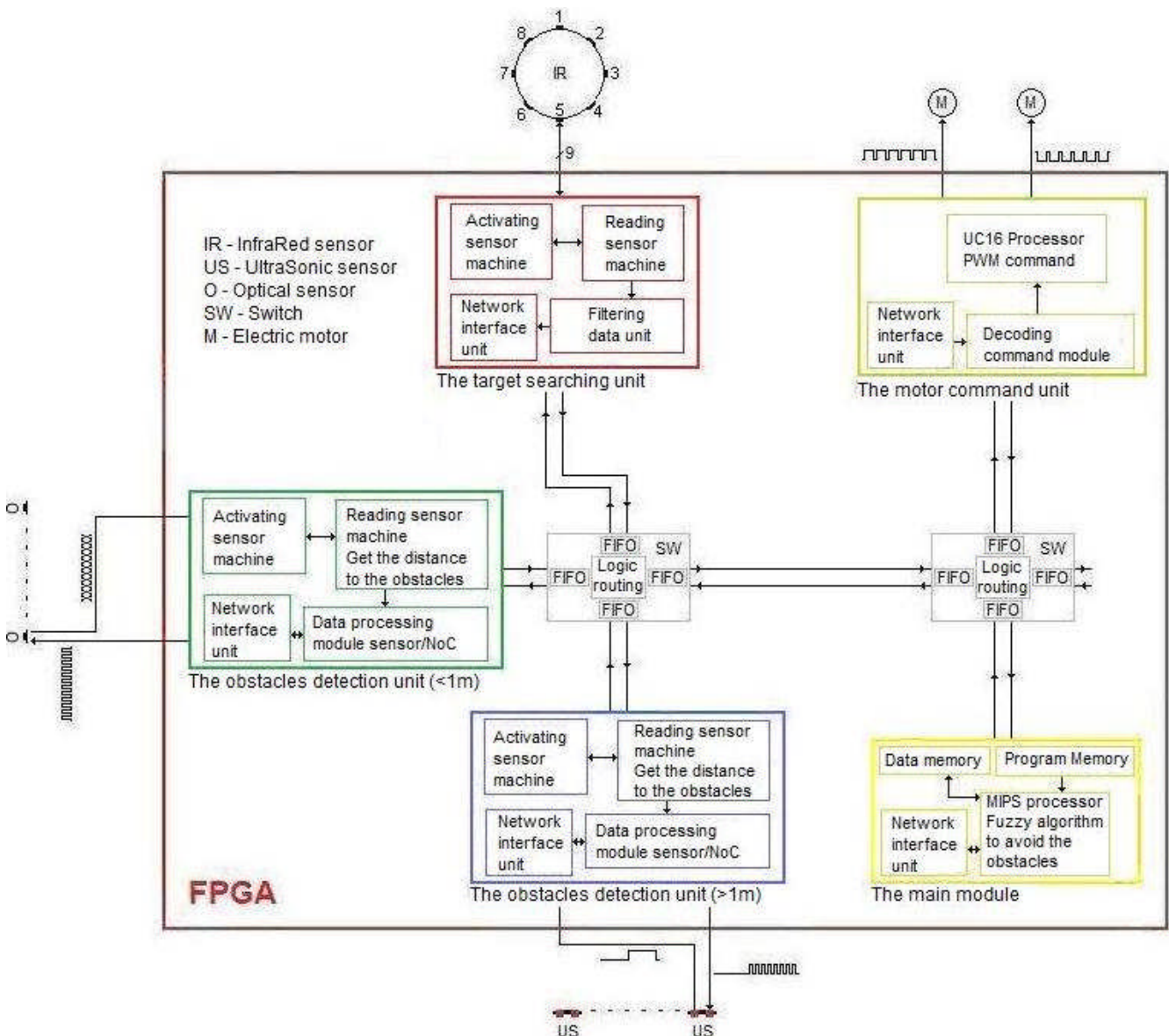

Fig. 2. Internal network of intelligent sensors

Functional units are:

- find the target unit, implemented as an asynchronous machine what scan the infrared sensors placed in a circle (simulating the operation of a radar), filters the data coming from them and send information

about the direction of the source to the other modules through the network;

- an unit to detect obstacles at distances greater than one meter and implemented like an automat that accesses the ultrasonic sensors, get data from them, process it and

send information about possible obstacles to the other modules;

- an unit to detect obstacles at distances of less than a meter, such as walls or furniture, implemented as an automatic that accesses the infrared Sharp sensors, get data from them, process it and send the information to other modules in order to maintaining a proper distance against them;

- a motor command module, implemented in around a 16-bit processor (UC16), which takes orders coming from the network and generates a PWM signal to command the CC motors, while making a slow passage through zero (in the case of an inverse order) for anti-overload them;

- the main module, implemented around a MIPS (pipeline) processor, which aims to retrieve information from the modules and find the path to following the target with avoid the obstacles using fuzzy techniques. This module is enable when "orders" from the sensors are contradictory;

- switch used to routing the network packages;
- network interface (NI) takes packages from the network and convert the data available for each module separately. They are not identical, but are suited for interfacing with each part.

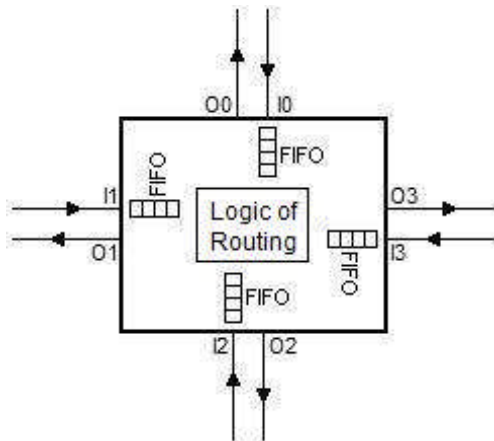

Fig. 3. Switch (block diagram)

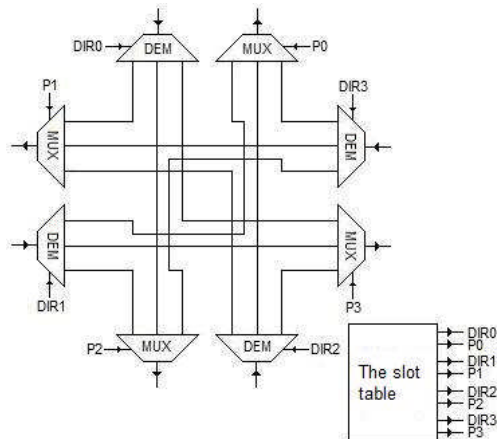

Fig. 4. The logic of routing unit

Each module has a unique address within the network and is connected to switches via the network interface.

The switches have four emission/reception interfaces used for connection with the adjacent switches or with network interfaces devices (Fig. 3). The inputs are buffered while the outputs are multiplexed for the selection of the direction of communication [3]. A logic of routing block that takes the decision of routing is also present (Fig. 4). It contains a routing table with six rows (six slots) and four columns for each outputs (Fig. 5).

	O0	O1	O2	O3
S0		I0		I2
S1			I0	I1
S2			I1	I0
S3			I1	I0
S4			I0	I1
S5		I0		I2

	O0	O1	O2	O3
S1	I2		I1	
S2	I1			
S3	I1			
S4	I2		I1	
S5			I1	
S0	I1			

Fig. 5. The slot table. (SW1 and SW2)

Each module processes data independently of other modules achieving a model of parallel computing. The modules are kept informed of the present situation through packages sent. They can make decisions separately [5].

The logical levels of the application are shown in Fig. 6.

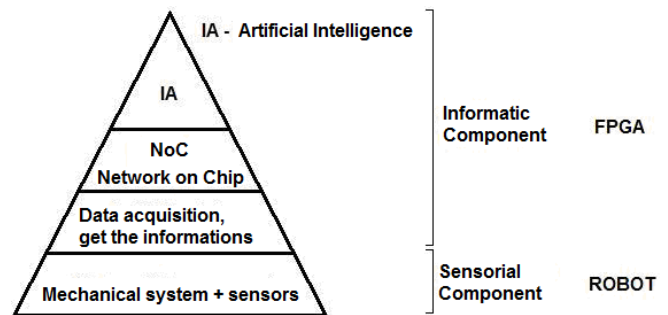

Fig. 6. Logical levels of the application

The strategy of navigation

It is using a reactive strategy of navigation, which implies the detection of a space without obstacles and follow the target. These are totally based on the sensorial information. The detection of a space without collisions is built with a STFIS (Self Tunable Fuzzy Interference System) that controls the speed and the linear velocity of the mobile robot. The variables ω and v are computed permanently by the implicated modules of intelligent sensors while the network is permanently informed with their values.

The structure of a FIS consists of triangular function members with the goal to extract and to show easily the final results. So, the output values $y(\omega$ or $v)$ are given by the formula:

$$y = \frac{\sum_{i=1}^n w_i \times \alpha_i}{\sum_{i=1}^n \alpha_i}, \quad (1)$$

where α_i are the true values for every component while w_i are the afferent loads for these.

The architecture of fuzzy control is shown in Fig 7.

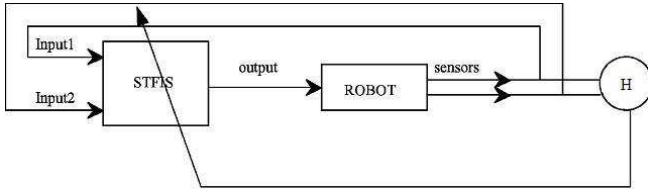

Fig. 7. The simplified architecture of a STFIS control system

Together, the modules implement a navigation system that is built through two elementary behaviors: a fuzzy controller with its own adjustment for detecting the middle of the free space and a component for detection and pursuit the target. The values ω and v – angular speed and linear velocity and they can have values within -1 and 1.

- $\omega = -1$ turning around strongly left
- $\omega = 1$ turning around strongly right
- $v = -1$ great speed forward
- $v = 1$ great speed backwards
- $\omega = v = 0$ robot stopped

These numerical values are translated in symbolic values in order to check the logic sense of these rules. We assign them a linguistic interpretation by form: PB (positive big) for values greater than 0,7, PS (positive small) for values between 0,2 and 0,7, Z (approximately zero) for values between -0,2 and 0,2, NS (negative small) for values between -0,7 and -0,2 and NB (negative big) for values lower than -0,7. Finally, it is obtained the linguistic table for the angular speed from the Table 1 [6][7].

Table 1. The linguistic table for the angular speed ω

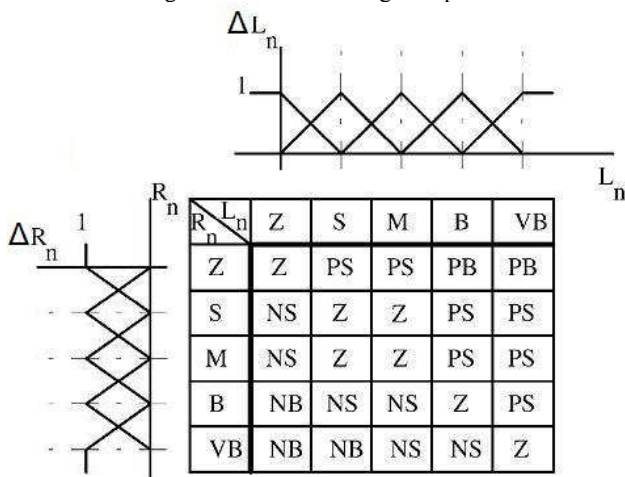

where:

$$R_n = \frac{R}{R+L}, L_n = \frac{L}{R+L}, F_n = \frac{F}{MAXRANGE}; \quad (2)$$

with:

$$F = \min(UL2, UL3),$$

$$R = \min(OP1, OP2, OP5, OP6, OP7, OP14, UL2),$$

$$L = \min(OP4, OP3, OP10, OP11, OP12, OP13, UL3).$$

If $v < 0$ then:

$$F = \min(UL8, UL9),$$

$$R = \min(OP4, OP3, OP10, OP11, OP12, OP13, UL3),$$

$$L = \min(OP1, OP2, OP5, OP6, OP7, OP14, UL2).$$

A similar structure is used for generating the control rules for the linear velocity v depending on the angular speed ω and the front distance F .

Table 2. The linguistic table for the linear velocity v

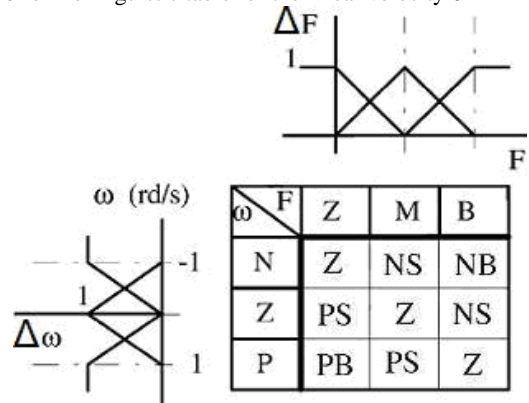

The feedback coefficient (see Fig. 7) is obtained with the formula:

$$H = \text{mod}(v - F); \quad (3)$$

Conclusions

Even if the idea of on-chip network appeared, it was never put into connection with intelligent systems. Systems much more complex than the actual ones can be obtained based on the same principle. These systems may control mobile autonomous auto-routed devices. They can process a very large quantity of information derived from a great number of sensors. At the same time, the systems SoC-NoC with intelligent sensors can be used in all fields where the machines need more information from the environment.

It can also use self-reconfigurable devices that can change on-line the architecture for calculation and for inter-sensorial communication, in order to gain an increased efficiency of the computational power and of the programming density.

As well as independent systems equipped with artificial intelligence and a massive sense will be forced to rethink the system and communication between functional blocks. Noc architectures can be a solution to these problems.

Acknowledgment

This work has been supported through the national research funding grant INTEROB in the framework of the Romanian Research of Excellence Programme, Ref. No. CEEX 131/2006 (INTEROB), grant TD – 161 / 01.10.2007

- Contributions to the Development of Computer aided design techniques of integrated structures.

References

1. **Rajesh Gupta.** On-chip networks // IEEE Design&Test of Computers - September-October 2005.
2. **Partha Pratim Pande, Cristian Grecu, Andre Ivanov.** Design, Synthesis, and Test of Networks on Chips // IEEE Design&Test of Computers - September-October 2005.
3. **Andre Ivanov, Giovanni De Micheli.** The Network-on-Chip Paradigm in Practice and Research // IEEE Design&Test of Computers - September-October 2005.
4. **Se-Joong Lee, Kangmin Lee, Hoi-Jun Yoo.** Analysis and Implementation of Practical, Cost-Effective Networks on Chips // IEEE Design&Test of Computers - September-October 2005.
5. **Kangmin Lee, Se-Joong Lee, Donghyun Kim, Kwanho Kim, Gawon Kim, Joungho Kim, Hoi-Jun Yoo.** Networks-on-chip and Networks-in-Package for High-Performance SoC Platforms // Dept. of Electrical Engineering, Korea Advanced Institute of Science and Technology (KAIST), Daejeon, Korea - 2006.
6. **H. Maaref, C. Barret.** Sensor-based navigation of a mobile robot in an indoor environment // Robotics and Autonomous Systems 38 - 2002.
7. **Luis Montesano, Javier Minguez.** Lesson Learned in Integration for Sensor-Based Robot Navigation Systems // Advanced Robotic Systems - 2006.

Received 2009 02 15

Cr. A. Tanase, A. Graur, V.G. Gaitan, V. Popa. Autonomous Mobile Device Controlled by On-chip Network of Intelligent Sensors for Indoor Environment Navigation // Electronics and Electrical Engineering. – Kaunas: Technologija, 2009. – No. 5(93). – P. 77–82.

The aim is to present the carrying out of an on-chip system (SoC) round about of an on-chip network (NoC) implemented on a FPGA structure. The hardware system is developed in order to control a mobile autonomous device that is able to search and track a mobile target, detecting and avoiding all obstacles in its route. The device consists mainly of two components: 1) Sensorial (Intelligent sensors) for searching the target and for detection of the obstacles, made up of a great number of sensors of different kinds; 2) Informatics to determine the target, establishing the route to go on, for analysis and control of the information taken over from the sensors. It is entirely implemented on a reprogrammable FPGA device. The developed system on-chip (SoC) is a network of functional units (NoC) that has to receive raw data from the sensors and to transform it in as much useful information as possible. Ill. 7, bibl. 7 (in English; summaries in English, Russian and Lithuanian).

Цр. А. Танасе, А. Граур, В. Г. Гайтан, В. Попа. Автономное мобильное устройство, управляемое при помощи сети интеллектуальных датчиков // Электроника и электротехника. – Каунас: Технология, 2009. – № 5(93). – С. 77–82.

Приведены интегральные системы, реализованные при помощи сети FPGA архитектуры интеллектуальных датчиков. Аппаратная часть системы контролирует мобильное автономное устройство, которое может обнаружить и сопровождать мобильную цель, на своем пути обнаруживая и избегая всех препятствий. Устройство состоит из двух основных компонентов: сенсорного компонента (интеллектуальных датчиков), предназначенного для обнаружения цели и препятствий и объединяющего большое количество датчиков разных типов; информационного компонента, предназначенного для определения цели, планирования маршрута, а также анализа и контроля информации, получаемой от датчиков. Устройство создано используя перепрограммируемую FPGA платформу. Созданная интегральная система (SoC) по сути есть сеть функциональных узлов интегральной сети (NoC), которые принимают необработанные данные из датчиков и трансформируют их в полезную информацию. Ил. 7, библи. 7 (на английском языке; рефераты на английском, русском и литовском яз.).

Cr. A. Tanase, A. Graur, V.G. Gaitan, V. Popa. Autonominis mobilus įtaisas, valdomas naudojant intelektualiųjų jutiklių tinklą // Elektronika ir elektrotechnika. – Kaunas: Technologija, 2009. – Nr. 5(93). – P. 77–82.

Pristatoma integrinė sistema, sukurta naudojant FPGA architektūros integrinių jutiklių tinklą. Sistemos aparatinė dalis kontroliuoja mobiliąjį autonominį įtaisą, kuris gali nustatyti ir sekėti mobiliųjų taikinių, kelyje aptikdamas visas kliūtis ir jų išvengdamas. Įtaisas sudarytas iš dviejų pagrindinių komponentų: 1) sensorinio (intelektualieji jutikliai), sudaryto iš didelio skaičiaus skirtingų tipų jutiklių ir skirto taikiniui ir kliūtims aptikti; 2) informacinio, skirto taikiniui nustatyti, maršrutui suplanuoti, iš jutiklių gautai informacijai analizuoti ir kontroliuoti. Įtaisas sukurtas naudojant perprogramuojamą FPGA platformą. Sukurtoji integrinė sistema (SoC) iš esmės yra tinklas funkcionaliųjų integrinio tinklo (NoC) mazgų, kurie priima neapdorotus duomenis iš jutiklių ir transformuoja juos į naudingą informaciją. Il. 7, bibl.7 (anglų kalba; santraukos anglų, rusų ir lietuvių k.).

DOI: 10.5755/j02.eie.10187