

Features of Implementation of the Modified "up-and-down" Method

K. Krūmiņš, V. Pētersons, V. Plociņš

Institute of Electronics and Computer Science,

Dzerbenes str. 14, Riga LV-1006, Latvia, phone +371-7-558115; e-mail: krumins@edi.lv

Introduction

Stroboscopic converters are divided into analogous and discrete converters. In analogous converters during the activity of narrow strobopulse accumulative capacitor is charged, voltage of which is proportional to the instantaneous value of the signal to be converted. In discrete stroboscopic converters instantaneous value of the input signal at the moment of clocking (strobing) is compared with the known threshold of the clocked comparator. If the threshold of the comparator is selected so that in case of multiple clocks response and refusal of the comparator becomes equiprobable, the obtained threshold is proportional to the instantaneous value of the input signal.

From the industrially produced converters to the said type one can relate, for example, converters PSP-1000 and PSP-750 produced by *Hypress*. Converters of this type are currently being intensely investigated because of the possibilities of increasing sensitivity and bandwidth [1, 2, 3].

The simplest method for selection of the threshold of the comparator in discrete stroboscopic converters is the so-called "up-and-down" method (hereinafter – the *ud* method). Measurement of instantaneous values of the input signal according to this method is done as follows.

Let in the phase t_i of time the instantaneous value of the signal be equal with $u_{1,i}$, masked with Gaussian additive noise X with variance $DX = \sigma_1^2$ and mean value $EX = 0$. Thus, it may be assumed that the input signal of the converter is

$$U_{1,i} = u_{1,i} + X, \quad (1)$$

which is compared to the threshold $e_{i,j}$. After comparison the following value of the threshold $e_{i,j+1}$ is set in accordance with the expression:

$$e_{i,j+1} = e_{i,j} + s * \text{sign}(U_{1,i} - e_{i,j}), \quad (2)$$

where s - step of the *ud* procedure.

After sufficiently large number of n clocks, we obtain the result of the measurement of the signal $u_{1,i}$ in the form of voltage $u_{2,i} = e_{i,n}$. After measurement of the instantaneous value of the input signal in phase t_i , the measurement phase is moved to t_{i+1} and the *ud* procedure is repeated with the initial value of the threshold $e_{i+1,1} = e_{i,n}$.

The result of such conversion is masked by the noise with the mean square deviation [4]:

$$\sigma_2 = \sqrt{0.625\sigma_1 s + 0.25s^2}. \quad (3)$$

In the expression (3) it can be seen that, for achieving the necessary noise suppression, a sufficiently small value of the step s should be set. It should be noted that decreasing of the step s causes increasing of the number of n clocking operations, since with

$$n < \frac{2}{\beta s} \ln \frac{sh \frac{\beta}{2} e_0}{sh \frac{\beta}{2} s}, \quad (4)$$

where $\beta = \frac{4}{\sigma\sqrt{2\pi}}$, the form of the signal is distorted [5].

Modified "up-and-down" method

Measurement of instantaneous values of an input signal according to the modified *ud* method (hereinafter the *udc* method) is carried out as follows. Comparison of the signal with the threshold and establishing each following value of the threshold is done in the same way as in case of the *ud* method. The result of the measurement of the instantaneous value of a noisy signal is determined in accordance with the expression

$$u_{2,i} = \frac{1}{n} \sum_{j=1}^n e_{i,j}. \quad (5)$$

After measurement of the instantaneous value of an input signal in the phase t_i , the phase of measurement is moved to t_{i+1} and the udc procedure is repeated with the initial value of the threshold $e_{i+1,1} = e_{i,n}$ the same as in case of the ud method.

In case of a noiseless signal the measurement result of the instantaneous value $u_{1,i}$ in accordance with the procedure ud will be $u_{2,i} \in (u_{1,i} - s; u_{1,i} + s)$. It is clear that in case of the udc procedure the measurement result of the noiseless signal will be displaced and the form of the converted signal – distorted. Therefore it is advisable to use the udc method only in case of severely noisy signals. To illustrate this, a statistical modelling of conversion of a noisy signal by means of the method ud and udc was carried out. As a signal to be converted there was used harmonic mono wave with the amplitude A_1 , masked with Gaussian additive noise with the mean square deviation $\sigma_1 = 1$. The results of the modelling are given in the Fig. 1 (method ud) and Fig. 2 (method udc) with the following conditions: $A_1 = 1$, $n = 1000$, $s = 0.1$, number of points of the phase in the period of the mono wave $n_T = 50$, number of points of the phase during the whole time base $N = 350$.

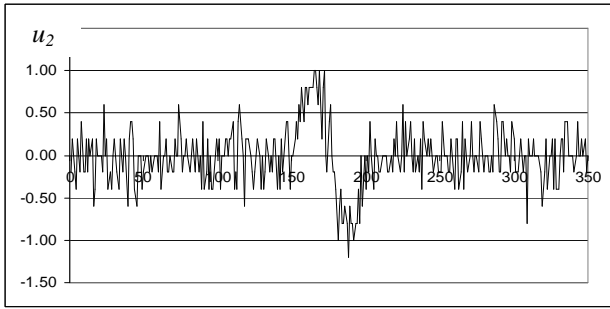

Fig. 1. Conversion result of a severely noisy signal by means of the ud method

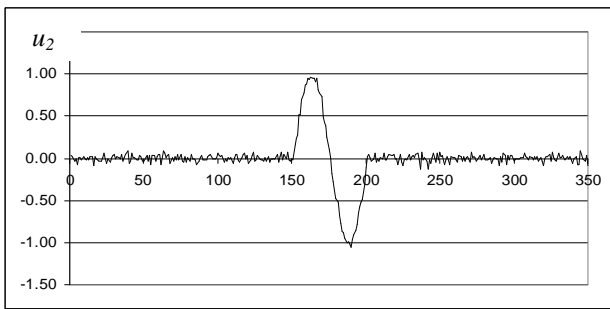

Fig. 2. Conversion result of the same signal by means of the udc method

Comparison of the obtained results shows that the method udc with the same conditions provide more efficient noise suppression.

In order to compare the methods ud and udc for conversion of a relatively high amplitude signal, a modelling with the following conditions were carried out: $A_1 = 35$, $n = 1000$, $s = 0.1$, $n_T = 50$, $N = 350$.

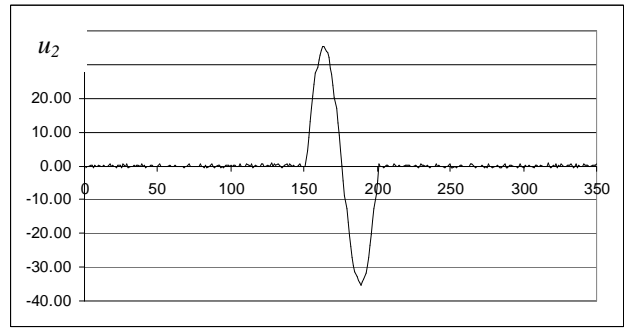

Fig. 3. Conversion result of a relatively high amplitude signal by means of the ud method

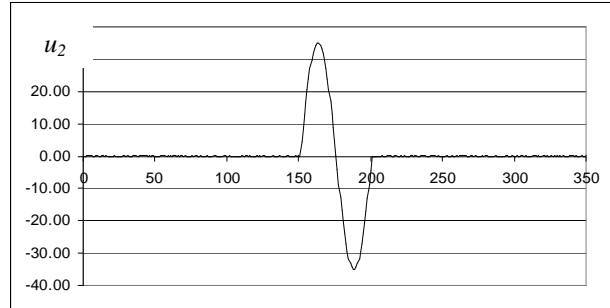

Fig. 4. Conversion result of the same signal by means of the udc method

The obtained results show that the method udc (Fig. 4) with a relatively high amplitude signal is also more efficient than the method ud (Fig. 3), though not so significantly.

Properties of the modified "up-and-down" method

In accordance with the previous studies [4], the mean square deviation of the result of noise conversion by means of the method udc is expressed as

$$\sigma_2 = 1.25 \frac{\sigma_1}{\sqrt{n}}. \quad (6)$$

From the expression (6) it is obvious, that the mean square deviation of the noise conversion does not depend on the size of the udc procedure step. To illustrate that, a statistical modelling of the noise conversion was carried out by means of the method udc with the following conditions: $\sigma_1 = 1$, $n = 1000$, $s = 0.001 \div 0.5$.

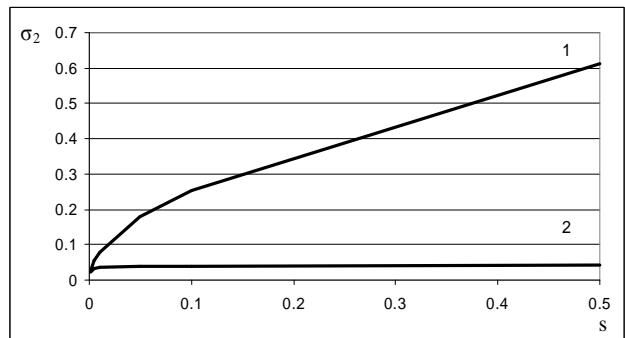

Fig. 5. Dependence of the mean square deviation of the noise at the converter output on the step s : 1 – method ud ; 2 – method udc

As the obtained results show (Fig. 5), in practically applicable range of the step s the mean square deviation of the result of the noise conversion does not depend on s . The results of the modelling match well with the results of theoretical calculations. In accordance with the expression (6) using $n = 1000$ we obtain $\sigma_2 = 0.039528$. According to the results of the modelling, for example, if $s = 0.1$ and $n = 1000$, we obtain $\sigma_2 = 0.040$. This feature allows using large values of the step s and thus ensures wider range of the amplitudes to be converted with the same noise level at the converter output.

Another feature, which may be used in practical implementation of the udc method, is based on auto correlation of the ud process. That allows averaging out not all n threshold values, but only an effective amount of selections [4]:

$$n^* = \frac{ns}{\sigma_1 \sqrt{2\pi}}. \quad (7)$$

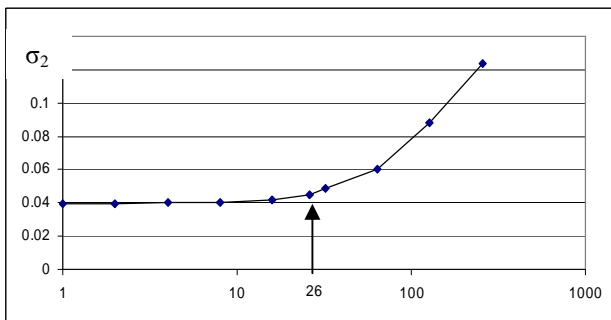

Fig. 6. Dependence of the mean square deviation of the noise at the converter output on the amount of the non-relevant in succession selections

In our example with $\sigma_1 = 1$, $n = 1000$, $s = 0.1$ in accordance with the expression (6) we obtain $n^* = 40$,

which corresponds to $\frac{n}{n^*} = \frac{1000}{40} \approx 26$ non-relevant in succession selections. This matches well the results of the modelling (see Fig. 6).

This feature allows with the given throughput of the processor to increase the clocking frequency by $\frac{n}{n^*}$ times.

Implementation flowchart of the modified "up-and-down" method

Implementation flowchart of the udc method is given in Fig. 7. The proposed equipment operates as follows. The input signal u and the compensation signal e , meant for changing the compensator's threshold, is supplied to the clocked comparator. The comparator is clocked by the clock signal v . At the same time the clock signal is supplied to the synchronisation input (clock input) C of the up-down counter. Binary signal (1 or 0) from the comparator output is supplied to the counter up-down input U/D. The code from the up-down counter is sent to the digital-analogous converter (DAC), forming the compensation signal e . At the same time the signal from the output of the up-down counter is sent to the input of the microcontroller MCU, calculating the value of the measurement result. The amount of the selections to be averaged is determined by the divider, installed between the strobe former (clock generator) and the RS-trigger. The output signal of the trigger is timing signal for acceptance of the date by the microcontroller. The measurement result from the output of the microcontroller is sent to the LCD indicator.

Phase shift of clocking is carried out by known methods (e.g., [6]); therefore phase shift in the flowchart is not depicted. The results of the theoretical calculation were confirmed by physical experiments with produced converter.

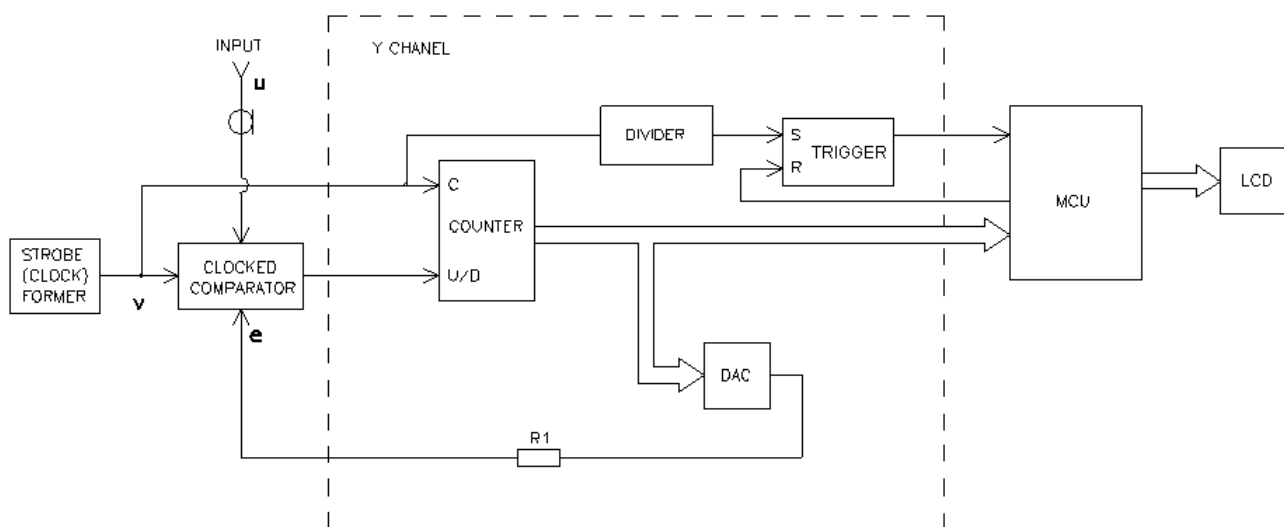

Fig. 7. Flowchart of implementation of the modified "up-and-down" method

Conclusions

1. The modified method provides more effective noise suppression in comparison with the standard "up-and-down" method.

2. Efficiency of noise suppression by the modified method may be improved by increasing the amount of clocking operations.

3. The modified method is not critical in selection of the step size of the threshold changing.

4. Autocorrelation feature of the converted noise allows using fewer values to be averaged. That makes it possible to increase the clocking frequency of the comparator with the given throughput of the microcontroller.

5. The physical experiments have demonstrated good match with the theoretical calculations.

References

1. Аскерзаде И. Н., Refik Samet. Переходная характеристика пары Гото на малых джозефсоновских переходах // ПЖТФ. – 2008. – Vol. 34, No. 17. – P. 26–31.

2. Maruyama M., Wakana H., Hato T., Suzuki H., Tanabe K., Uekusa K., Konno T., Sato N., Kawabata M. HTS Sampler with Improved Circuit Design and Layout // IEICE Transactions on Electronics E90-C. – 2007. – P. 579–587.
3. Suzuki H., Hato T., et al. Progress in HTS Sampler Development // Physica C. – Oct. 2005. – Vol. 426–431. – P. 1643–1649.
4. Krūmiņš K. and Kārklis V. The method "up-and-down" modifications at the mode of detection low signals for superwideband radars // Automatic Control and Computer Sciences. – New York: Allerton Press, 2005. – Vol. 39, No. 4. – P. 70–77.
5. Krūmiņš K. Noisy Signal Tracking in the Sampling Converter by the „Up and Down” Method. – Workshop on Sampling Theory & Applications. – Jūrmala, Latvia. – September, 1995. – P. 215–218.
6. Рябинин Ю. А. Стробоскопическое осциллографирование // Москва: Советское радио. – 1972.

Received 2009 02 18

K. Krūmiņš, V. Pētersons, V. Pločiņš. Features of Implementation of the Modified "up-and-down" Method // Electronics and Electrical Engineering. – Kaunas: Technologija, 2009. – No. 5(93). – P. 51–54.

There is described the modified "up-and-down" method and illustrated the advantages of the said method in comparison with the standard "up-and-down" method. The modified method is not critical in selection of the step size of the threshold changing. The autocorrelation feature of the converted noise is used for decreasing the amount of averaged values. There is given the flowchart of the practical implementation of the modified method to be used in discrete stroboscopic converters. Il. 7, bibl. 6 (in English; summaries in English, Russian and Lithuanian).

К. Круминьш, В. Петерсонс, В. Плоциньш. Особенности осуществления модифицированного „up-and-down” метода // Электроника и электротехника. – Каунас: Технология, 2009. – № 5(93). – С. 51–54.

Излагается модифицированный „up-and-down” метод и иллюстрируются его преимущества, по сравнению со стандартным „up-and-down” методом. Модифицированный метод не критичен к выбору величины шага изменения порога. Свойство автокорреляции преобразованного шума используется для уменьшения количества усредняемых величин. Приведена блок-схема практической реализации модифицированного метода для использования в дискретных стробоскопических преобразователях. Ил. 7, библи. 6 (на английском языке; рефераты на английском, русском и литовском яз.).

K. Krūmiņš, V. Pētersons, V. Pločiņš. Modifikuoto aukštyn-žemyn metodo taikymo aspektai // Elektronika ir elektrotechnika. – Kaunas: Technologija, 2009. – Nr. 5(93). – P. 51–54.

Aprašomas modifikuotas aukštyn-žemyn metodas bei iliustruojami jo pranašumai lyginant su standartiniu variantu. Modifikuotą metodą taikyti pasirenkant slenkstinės vertės dydžio keitimo žingsnį nėra būtina. Konvertuoto triukšmo autokoreliacinė savybė panaudojama suvidurkintų verčių kiekiui mažinti. Pateikiama praktinės modifikuoto metodo realizacijos schema, kurią galima naudoti stroboskopiniuose keitikliuose. Il. 7, bibl. 6 (anglų kalba; santraukos anglų, rusų ir lietuvių k.).

DOI: 10.5755/j02.eie.10180