

Using Complex Conjugated Magnitudes- and Orthogonal Park/Clarke Transformation Methods of DC/AC/AC Frequency Converter

B. Dobrucky, M. Benova, P. Spanik

*University of Zilina,
 Univerzita1, Zilina, Slovakia, phone: +421 41 5131602; e-mail: dobrucky@fel.uniza.sk*

Introduction

The paper deals with mathematical modeling of two-stage frequency converter system with induction motor. There are used two special methods of investigation: method of complex conjugated amplitudes, and the orthogonal Park/Clarke transformation method. The first one is used for steady-state investigation; the second one is suitable for investigation of three-phase electric circuits. The combination of both methods is very useful for analysis of three-phase electric motors in steady-state condition: constant angular speed, and when operator d/dt in its dynamical model is substituted by operator $j.v.\omega.t$. Then the effect of individual harmonic components on motor properties can be investigated.

Methods Used for Modelling and Calculation

Method of complex amplitudes has been introduced by Takeuchi [1] for analysis of converter circuit supplied electric machines in steady-state. The principle is based on substitution of trigonometric function by exponential one with complex argument. After determination of investigated variable in complex form, the variable can be than transformed back into time domain. Regarding to non-harmonic time waveforms of converter quantities the Fourier analysis is used for variables as the first step.

Method of orthogonal transformation for electrical quantities was introduced by Park [2] for three-phase electric machines. The method makes it possible to transform symmetrical 3-phase system into equivalent two-phase orthogonal system. This transformation decreases number of differential equations (from 3 to 2), and removes variable coefficients in the equations. Besides, trajectories of the quantities in complex Gauss plane denote themselves by six-side symmetry, thus the steady-state quantities can be calculated in only one sixth of time period. Clarke's multiplicative transformation constant (equal $2/3$) provides the invariances of voltage and current quantities in the both coordinating systems.

Using of Complex Conjugated Amplitude Methods for Electrical Circuit Fed by Single-Phase Inverter

For rectangular form of electric voltage with cosine harmonic components, the sum of its odd harmonic components can be written as:

$$u(t) = \frac{4U_0}{\pi} \sum_{\nu=0}^{\infty} (-1)^{(2\nu+1)} \frac{\cos((2\nu+1)\omega t)}{(2\nu+1)} \quad (1)$$

for non-negative integer ν (from interval $\langle 0; \infty \rangle$), constant supply voltage of inverter U_0 and constant angular frequency ($\omega = 2\pi f_0$)

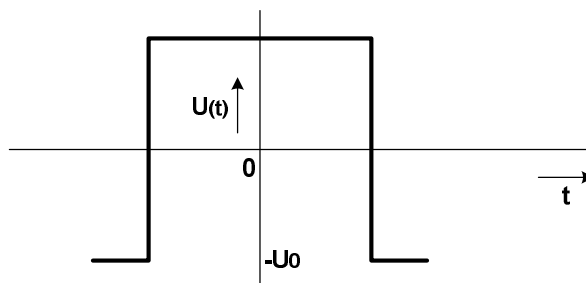

Fig.1. Rectangular time-waveform of single phase inverter voltage with cosine harmonic components

Let us apply such a voltage to passive R - L circuit whose complex impedance is:

$$\underline{Z}_{2\nu+1} = R + j(2\nu+1)\omega L = |Z_{2\nu+1}| e^{j\varphi_{2\nu+1}}, \quad (2)$$

where $\underline{Z}_{2\nu+1}$ – complex impedance, R – resistance of the circuit, j – complex unit ($= \sqrt{-1}$), L – inductance of the circuit, $|Z_{2\nu+1}|$ – module (magnitude) of complex impedance ($= \sqrt{R^2 + (2\nu+1)^2 \omega^2 L^2}$), $\varphi_{2\nu+1}$ – argument (phase angle) of \underline{Z} ($= \arctan \frac{(2\nu+1)\omega L}{R}$).

Using Euler relations the non-harmonic voltage can be expressed as

$$u(t) = \frac{2U_0}{\pi} \sum_{\nu=0}^{\infty} (-1)^{2\nu+1} \frac{e^{j(2\nu+1)\omega t} + e^{-j(2\nu+1)\omega t}}{(2\nu+1)}. \quad (3)$$

Then corresponding complex current is

$$i(t) = \frac{2U_0}{\pi} \sum_{\nu=0}^{\infty} (-1)^{2\nu+1} \frac{e^{j(2\nu+1)\omega t} + e^{-j(2\nu+1)\omega t}}{(2\nu+1)(R + j(2\nu+1)\omega L)}, \quad (4)$$

that can be written in complex conjugated magnitude form:

$$i(t) = \frac{1}{\sqrt{2}} \sum_{\nu=0}^{\infty} (I_{2\nu+1} e^{j(2\nu+1)\omega t} + I_{2\nu+1}^* e^{-j(2\nu+1)\omega t}), \quad (5a)$$

where complex magnitude of current will be

$$I_{2\nu+1} = \frac{2\sqrt{2}}{\pi} \frac{(-1)^{2\nu+1}}{2\nu+1} \frac{U_0 e^{-j\varphi_{2\nu+1}}}{\sqrt{R^2 + (2\nu+1)^2 \omega^2 L^2}} \quad (5b)$$

and complex conjugate current magnitude

$$I_{2\nu+1}^* = \frac{2\sqrt{2}}{\pi} \frac{(-1)^{2\nu+1}}{2\nu+1} \frac{U_0 e^{j\varphi_{2\nu+1}}}{\sqrt{R^2 + (2\nu+1)^2 \omega^2 L^2}}. \quad (5c)$$

Finally, by adapting of (5) and by substitution in the equation (4) with using (2), for current form in time domain one will obtain

$$i(t) = \frac{4U_0}{\pi} \sum_{\nu=0}^{\infty} \frac{(-1)^{2\nu+1}}{(2\nu+1)} \frac{\cos[(2\nu+1)\omega t - \varphi_{2\nu+1}]}{\sqrt{R^2 + (2\nu+1)^2 \omega^2 L^2}}. \quad (6)$$

Note: Eq. (6) is approximated numerical solution of ordinary differential equation

$$\frac{di(t)}{dt} = -\frac{R}{L} \cdot i(t) + \frac{1}{L} \cdot u(t). \quad (7)$$

The relation for resulting current wave-form can be obtained also in compact closed form using classical analytical solution, Laplace transform or z-transform [3]

$$i(t) = \frac{U_0}{R} \cdot (1 - e^{-t/\tau}) + I_0 \quad (8)$$

$$\text{and } i(t) = \frac{U_0}{R} \cdot \frac{1 - e^{-T/2\tau}}{1 + e^{-T/2\tau}} = \frac{U_0}{R} \cdot \tanh\left(\frac{T}{4\tau}\right), \quad (9)$$

where τ – time constant of the circuit, $\tau = L/R$.

Anyway, the solution (6) makes it possible to analyse more exactly each harmonic component (of current) comprised in total waveform

$$i_{2\nu+1}(t) = \frac{4U_0}{\pi} \frac{(-1)^{2\nu+1}}{2\nu+1} \frac{1}{|Z_{2\nu+1}|} \cdot \cos[(2\nu+1)\omega t - \varphi_{2\nu+1}]. \quad (10)$$

The waveforms whose Fourier series analysis leads to sine functions of the harmonics can be expressed by the similar way, Fig. 2.

$$u(t) = \frac{4U_0}{\pi} \sum_{\nu=0}^{\infty} \frac{\sin(2\nu+1)\omega t}{(2\nu+1)}, \quad (11)$$

$$i(t) = \frac{4U_0}{\pi} \sum_{\nu=0}^{\infty} \frac{\sin[(2\nu+1)\omega t - \varphi_{2\nu+1}]}{(2\nu+1)\sqrt{R^2 + (2\nu+1)^2 \omega^2 L^2}}. \quad (12)$$

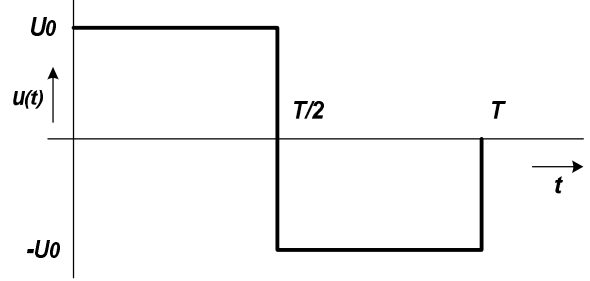

Fig. 2. Rectangular time-waveform of single phase inverter voltage with sine harmonic components

The rectangular pulse time-waveforms as is shown on Fig.3 can be expressed by the similar way

$$u(t) = \frac{4U_0}{\pi} \sum_{\nu=0}^{\infty} \frac{\cos\left((2\nu+1)\frac{\pi}{6}\right)}{2\nu+1} \sin(2\nu+1)\omega t, \quad (13)$$

$$i(t) = \frac{4U_0}{\pi} \sum_{\nu=0}^{\infty} \frac{\cos\left((2\nu+1)\frac{\pi}{6}\right) \sin[(2\nu+1)\omega t - \varphi_{2\nu+1}]}{(2\nu+1)\sqrt{R^2 + (2\nu+1)^2 \omega^2 L^2}}. \quad (14)$$

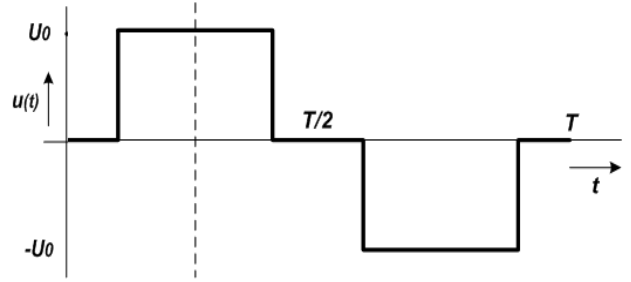

Fig. 3. Rectangular pulse time-waveform of single phase of three phase's inverter voltage

Electrical model of 2-stage converter

Scheme of the 2-stage converter is shown in Fig. 4. It comprises two semiconductor type of converters [4]:

- single-phase voltage inverter as the first stage,
- three-phase matrix converter or cycloconverter as the second stage.

The first stage operates with constant voltage U_0 and fixed frequency f_0 . The second one supplies passive R - L or active load (electric motor) with variable output frequency and which is much lesser than frequency of AC interlink between stages.

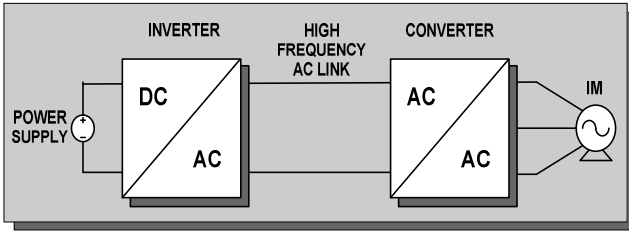

Fig. 4. Overall schematic diagram of 2-stage 3-phase DC/AC/AC converter

Considering rectangular form of the phase-voltage length of $2\pi/3$ radians with I_0 equal U_0/R , the scheme can be reconfigured to the scheme of three-phase current inverter with IM motor load [4], Fig. 5, whereas commutating capacitors could be omitted because of switches of inverter are switch-off capability. Control of such system is described in greater detail in [5].

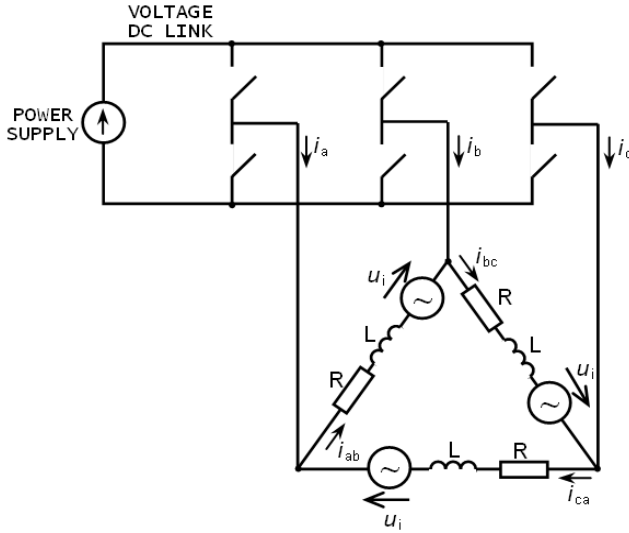

Fig. 5. Transfigured scheme of three-phase voltage inverter with IM motor load in delta connection

Mathematical model of 2-stage converter

The phase voltage of the three-phase current inverter (Fig. 6) can be expressed by Fourier series

$$u(t) = \sum_{n=0}^{\infty} [a_n \cos n \omega t + b_n \sin n \omega t], \quad (15)$$

where a_n and b_n – coefficients of Fourier series.

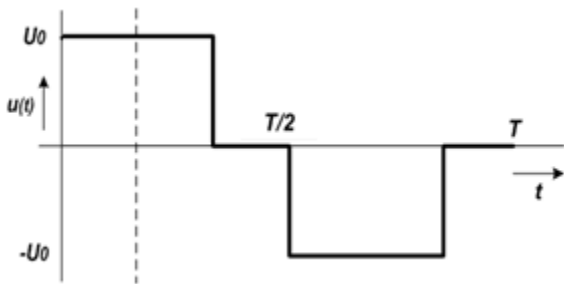

Fig. 5. Rectangular pulse time-waveform of single phase of three phase's inverter voltage

The coefficients for odd $n (=2\nu+1)$ will then be

$$a_{2\nu+1} = \frac{2U_0}{\pi} \frac{\sin(2\nu+1)\frac{2\pi}{3}}{2\nu+1}, \quad (16a)$$

$$b_{2\nu+1} = \frac{2U_0}{\pi} \left[\frac{1 - \cos(2\nu+1)\frac{2\pi}{3}}{2\nu+1} \right]. \quad (16b)$$

Using equations (15)-(16b) and complex magnitudes method, the voltage will be

$$u(t) = \frac{4U_0}{\pi} \sum_{\nu=0}^{\infty} \frac{\sin\left((2\nu+1)\frac{\pi}{3}\right) \cdot \cos\left[(2\nu+1)\left(\omega t - \frac{\pi}{3}\right)\right]}{2\nu+1}. \quad (17)$$

Implementation of orthogonal transformation

Based on definition of complex-time vector by Park [2] the real- and imaginary parts of the vector can be obtained:

$$\underline{u}(t) = \frac{2}{3} [u_a(t) + \underline{a}u_b(t) + \underline{a}^2u_c(t)] = u_{\alpha}(t) + ju_{\beta}(t), \quad (18)$$

the real- and imaginary parts of the vector can be obtained:

$$u_{\alpha}(t) = \frac{1}{3} [2u_a(t) - u_b(t) - u_c(t)], \quad (19)$$

$$u_{\beta}(t) = \frac{\sqrt{3}}{3} [u_b(t) - u_c(t)]. \quad (20)$$

Considering sum of phase voltages to be zero:

$$u_a(t) + u_b(t) + u_c(t) = 0, \quad (21)$$

real- and imaginary parts will be

$$u_{\alpha}(t) = u_a(t), \quad u_{\beta}(t) = \frac{u_b(t) - u_c(t)}{\sqrt{3}}, \quad (22)$$

under considering sum of phase voltages to be zero.

Voltage of a -phase of the inverter then will be

$$u_{\alpha}(t) = u_a(t) = \frac{4U_0}{\pi} \sum_{\nu=0}^{\infty} \frac{\sin\left((2\nu+1)\frac{\pi}{3}\right) \cdot \cos\left[(2\nu+1)\left(\omega t - \frac{\pi}{3}\right)\right]}{2\nu+1}. \quad (23)$$

Voltage of b -phase lags the voltage of a -phase, thus

$$\begin{aligned} \sqrt{3}u_{\beta}(t) &= u_b(t) - u_c(t) = \\ &= -\frac{8U_0}{\pi} \sum_{v=0}^{\infty} \frac{\sin^2\left((2v+1)\frac{\pi}{3}\right) \cdot \sin\left[(2v+1)\left(\omega t + \frac{2\pi}{3}\right)\right]}{2v+1}. \end{aligned} \quad (24)$$

Note: it is to be aware of the fact that Eqs. (23) and (24) create orthogonal series for u_a and u_{β} [3], [6-8], which can be processed by orthogonal Fourier series rules.

Determination of phase current of load in steady-state

Based on (19), (20) the differences of the phase voltages are $u_b - u_c$, indeed, the β -components of Park complex time-vector, multiplied by constant $\sqrt{3}$ by (24) and the difference of phase-voltages $u_a(t) - u_b(t)$ then similarly will be

$$\begin{aligned} u_a(t) - u_b(t) &= \\ &= -\frac{8U_0}{\pi} \sum_{v=0}^{\infty} \frac{\sin^2\left((2v+1)\frac{\pi}{3}\right) \cdot \sin\left[(2v+1)\left(\omega t - \frac{2\pi}{3}\right)\right]}{2v+1}. \end{aligned} \quad (25)$$

Since

$$\begin{aligned} u_a(t) - u_b(t) &= \quad (26) \\ &= u_i + (R + j(2v+1)\omega L) \cdot [(i_{ab}(t) - i_{ca}(t)) - (i_{bc}(t) - i_{ab}(t))] \end{aligned}$$

and

$$i_{ab}(t) + i_{bc}(t) + i_{ca}(t) = 0, \quad (27)$$

then

$$u_a(t) - u_b(t) = u_i + 3 \cdot i_{ab}(t) \cdot (R + j(2v+1)\omega L). \quad (28)$$

Load current i_{ab} then will be

$$i_{ab}(t) = \frac{u_a(t) - u_b(t) - u_i}{3 \cdot (R + j(2v+1)\omega L)} = \frac{u_a(t) - u_b(t) - u_i}{3 \cdot |Z_{2v+1}| e^{j\varphi_{2v+1}}}. \quad (29)$$

After substituting $u_a(t) - u_b(t)$ by (26) the current can be expressed as

$$\begin{aligned} i_{ab}(t) &= \\ &= \sum_{v=0}^{\infty} \frac{1}{3 \cdot Z_n} \left(-\frac{8U_0}{\pi} \cdot \frac{\sin^2\left(n\frac{\pi}{3}\right)}{n} \cdot \sin\left[n\left(\omega t - \frac{2\pi}{3}\right)\right] - u_i \right) = \\ &= \sum_{v=0}^{\infty} \frac{1}{3} \left(-\frac{8U_0}{\pi} \cdot \frac{\sin^2\left(n\frac{\pi}{3}\right)}{n|Z_n|} \cdot \sin\left[n\left(\omega t - \frac{2\pi}{3} - \varphi_n\right)\right] - \frac{u_i}{Z_n} \right) \end{aligned} \quad (30a)$$

$$\begin{aligned} i_{ab}(t) &= -\sum_{v=0}^{\infty} \frac{u_i}{3 \cdot Z_n} - \\ &= -\frac{4U_0}{3\pi} \sum_{v=0}^{\infty} \frac{\sin^2\left(n\frac{\pi}{3}\right)}{n} \cdot \frac{1}{Z_n} \cdot \left(e^{jn\left(\omega t - \frac{2\pi}{3}\right)} - e^{-jn\left(\omega t - \frac{2\pi}{3}\right)} \right), \end{aligned} \quad (30b)$$

where $n = 2v+1$, $|Z_n| = |Z_{2v+1}| = \sqrt{(R^2 + (2v+1)^2 \omega^2 L^2)}$;
 $\varphi_n = \varphi_{2v+1} = \arctan\left(\frac{(2v+1)\omega L}{R}\right)$.

Model of induction machine

The key assumptions in the model of induction motor are:

- stator windings are distributed to produce sinusoidal MMF in space,
- the rotor bars or coils are arranged such that at any instant, the rotor MMF waves are sinusoidal in space and have the same number of poles as the corresponding stator MMF wave,
- the air gap is uniform,
- the magnetic circuit is linear.

The equations of the machine are:

$$u_{\alpha s} = pA_{\alpha s} + r_1 \cdot i_{\alpha s}, \quad (31)$$

$$u_{\beta s} = pA_{\beta s} + r_1 \cdot i_{\beta s}, \quad (32)$$

$$0 = pA_{\alpha r} + r_2 \cdot i_{\alpha r} + \omega_r \cdot A_{\beta r}, \quad (33)$$

$$0 = pA_{\beta r} + r_2 \cdot i_{\beta r} - \omega_r \cdot A_{\alpha r}. \quad (34)$$

In the equations ω_r – the rotor speed, p – the time-derivative operator, A – the fluxes linking the subscripted windings, $A \cdot \omega_r$ – rotating voltage.

Voltages of stator and rotor can be derived for d,q voltages

$$u_{d,q} = u_{\alpha,\beta} \cdot e^p \quad (35)$$

Considering rotor speed equal zero and substituting time-derivative operator p by $j \cdot v \cdot \omega t$ currents of the stator or/and rotor can be calculated in the form of Fourier series.

Simulation experiments results

Based on above mentioned equation (23)-(35) the following simulations in Gauss plane and in time-domain have been programmed in Matlab programming environment.

Parameters of the circuit: $R = 1$ Ohm, $L = 5$ mH, $U_0 = 100$ V, $u_i = f(\omega_r)$.

Parameters of the simulation: time increment $\Delta T = 1$ μ s, number of considered odd harmonic components from 1 up to 999. Version of Mat Lab programming environment: R2007b

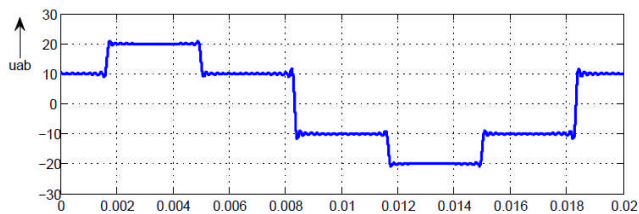

Fig. 7. Time waveform of terminal voltage u_{ab} of the inverter

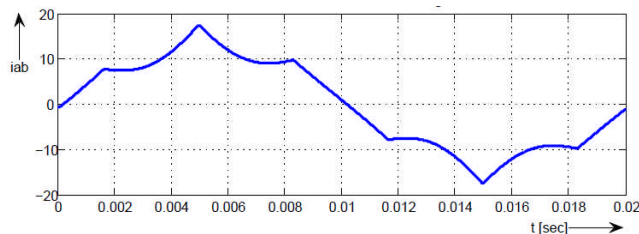

Fig. 8. Phase current i_{ab} of the IM during run

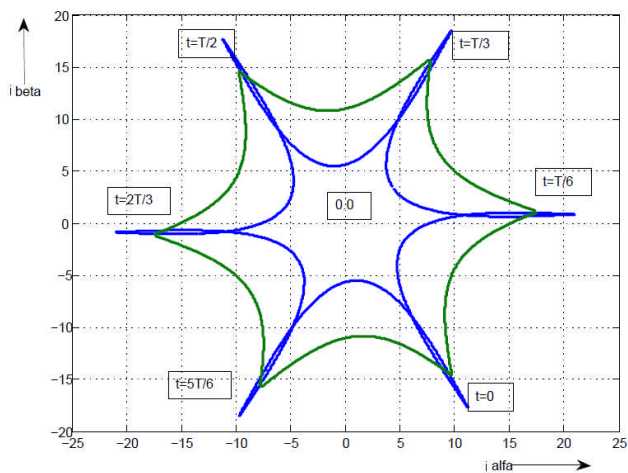

Fig. 9. Trajectory of current vectors of IM in Gauss plane for two case of load

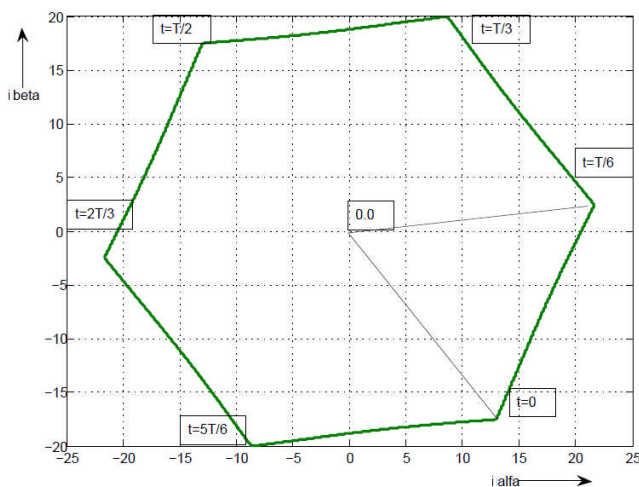

Fig. 10. Trajectory of current vector of IM in Gauss plane at zero speed

Conclusions

The relation for resulting current wave-form can be obtained also in compact closed form using classical analytical solution, Laplace transform and similar methods.

Anyway, the solution given in the paper makes possible to analyse more exactly effect of each harmonic component comprised in total waveform on induction motor quantities.

The simulation experiments have shown very good coincidences of theoretical and simulated results.

Acknowledgement

The authors would like to thank to the Slovak Grant Agency of the Ministry of Education of the Slovak Republic for financial support of the Vega project No. 1/0470/09 "Research of Topology and Control of Power Electronic System with Single-Phase HF Input and Two-Phase Orthogonal Output for SM/IM Electrical Motor.

References

1. **Takeuchi T. J.** Theory of SCR Circuit and Application to Motor Control. – Tokyo: Electrical Engineering College Press, 1968. – Russian Edition – Leningrad-St. Petersburg: Energia Publisher, 1973. – 248 p.
2. **Park R. H.** Two Reaction Theory of Synchronous Machine. Generalized Method of Analysis – Part I // IEEE Transactions. – July 1999. – Vol. 48. – P. 716–730.
3. **Marcokova M.** Equiconvergence of Two Fourier Series // Journal of Approximation Theory. – 1995. – Vol. 80, No. 2. – P. 151–163.
4. **Bala S.** Dynamics of Single/Two Phase Induction Motor. University of Wisconsin-Madison (USA) [interactive]. Accessed at: <http://homepages.cae.wisc.edu/~sbala/scieng/04-singleph.pdf>.
5. **Gonthier I., Bernot F., Bocus S. D., Elbaroudi S., Berthon A.** High-Efficiency Soft-Commutated DC-AC-AC Converter for Electric Vehicles // Journal ElectroMotion (5). – Mediamira Science Publisher (RO). – 1998. – No. 2. – P. 54–64.
6. **Marcoková M., Stancek V.** On Polynomials Orthogonal in a Finite (Symmetric) Interval // Acta mathematica 9. – 2006. – P. 209–214.
7. **Dobrucky B., Marcoková M., Sul R.** Prediction of Periodical Variable Structure System Behaviour using Minimum Data Acquisition Time // Proc. of the 26th IASTED MIC'07 – Int'l Conf. on Modeling, Identification and Control, Innsbruck (AT). – 12-14 Feb. 2007.
8. **Dobrucky B., Marcokova M., Kabasta M.** Using Orthogonal Transform for Solution of Matrix Converter Power Circumstances in Mathematica Environment // Proc. of ApliMat 08 Int'l Conf. on Applied Mathematics. – Bratislava (SK). – Feb. 2008. – P. 54.
9. **Dobrucky B., Šul R., Beňová M.** Mathematical modelling of two-stage converter using complex conjugated magnitudes and orthogonal Park/Clarke transformation methods // Proc. of ApliMat 08 Int'l Conf. on Applied Mathematics. – Bratislava (SK). – Feb. 2009.
10. **Dobrucky B., Beňová M., Pokorný M.** Using Virtual Two Phase Theory for Instantaneous Single-Phase Power System Demonstration // Przegląd Elektrotechniczny (PL). – 2009. – Vol. 85, No. 1. – P. 174-178.

Received 2009 03 27

B. Dobrucky, M. Benova, P. Spanik. Using Complex Conjugated Magnitudes- and Orthogonal Park/Clarke Transformation Methods of DC/AC/AC Frequency Converter // Electronics and Electrical Engineering. – Kaunas: Technologija, 2009. – No. 5(93). – P. 29–34.

The paper deals with mathematical modeling of two-stage frequency converter system with induction motor. There are used two special methods of investigation: method of complex conjugated amplitudes, and the orthogonal Park/Clarke transformation method. The first one is used for steady-state investigation; the second one is suitable for investigation of three-phase electric circuits. The combination of both methods is very useful for analysis of three-phase electric motors in steady-state condition: constant angular speed, and when operator d/dt in its dynamical model is substituted by operator j, v, ω, t . Then the effect of individual harmonic components on motor properties can be investigated. Il. 9, bibl. 10 (in English; summaries in English, Russian and Lithuanian).

Б. Добруцки, М. Бенова, П. Шпаник. Использование методов комплексных объединенных амплитуд и ортогональной трансформации Park/Clarke в преобразователе частоты DC/AC/AC // Электроника и электротехника. – Каунас: Технология, 2009. – № 5(93). – С. 29–34.

Описывается математическое моделирование системы двухступенчатого преобразователя частоты с индукционным двигателем. При исследовании применяются два метода: комплексных объединенных амплитуд и ортогональной трансформации Park/Clarke. При помощи первого анализируется постоянное состояние, а второй более пригодный для исследования трехфазных электрических цепей. Сочетание обоих методов полезно при анализе трехфазных электродвигателей при постоянной угловой скорости и когда оператор динамической модели d/dt заменяется на операторы j, v, ω, t . Показана возможность исследования влияния отдельных гармоник на свойства двигателя. Ил. 9, библи. 10 (на английском языке; рефераты на английском, русском и литовском яз.).

B. Dobrucky, M. Benova, P. Spanik. Kompleksinių jungtinių amplitudžių ir ortogonalios Parko ir Klarko transformacijos metodų taikymas DC/AC/AC dažnio keitiklyje // Elektronika ir elektrotechnika. – Kaunas: Technologija, 2009. – Nr. 5(93). – P. 29–34.

Aprašomas dviejų pakopų dažnio keitiklio sistemos su indukciniu varikliu matematinis modeliavimas. Taikomi du tyrimo metodai: kompleksinių jungtinių amplitudžių ir ortogonalios Parko ir Klarko transformacijos. Pirmuoju analizuojama pastovioji būseną, o antrasis tinka trifaziams elektriniams grandynams tirti. Abiejų metodų derinys naudingas trifaziams elektros varikliams analizuoti, esant pastoviam kampiniam greičiui ir kai jo dinaminio modelio operatorius d/dt pakeičiamas operatoriais j, v, ω, t . Parodyta galimybė tirti atskirų harmonikų poveikius variklio savybėms. Il. 9, bibl.10 (anglų kalba; santraukos anglų, rusų ir lietuvių k.).

DOI: 10.5755/j02.eie.10174