

Modelling of Parameters of Building Earthing Devices

N. Bagdanavičius^{1,2}, D. Eidukas¹, A. Drabatiukas², Š. Kilius²

¹ Department of Electronics Engineering, Kaunas University of Technology

Studentų str. 50, 51368 Kaunas, e-mail: n.bagdanavicius@gmail.com

² Department of Energetics and Electronics, Kaunas Technical College

Tvirtovės av. 35, 50155 Kaunas, phone: +370 37 308626, e-mail: drabatiukas@yahoo.com, sarunas@meganet.lt

Parameters of the earthing devices

Earthing equipment consists of the multifunctional devices and has to conform to all safety, operational requirements for devices of protection from atmospheric surges and electromagnetic compatibility earthing. For this reason the operational characteristics of the electrical grounding (input resistance, lengths of work, touch and step voltages, etc.) have to be researched under the presence both of alternating (frequency of 50 Hz) and pulsed current. It is obvious that wave parameters of the earthing device also possess the practical and scientific interest. These are: wave propagation constant and velocity, wave resistance, reflection and refraction indexes. These parameters are required when investigating the distribution of lightning currents and voltages in the objects containing the discrete earthing.

Energy spectrum of the lightning current is very wide; lightning current varies from 2 kA (probability 85 – 90 %) up to 200 kA (probability 0.7 – 1.0 %). In order to determine the current flowing through the earthing system and through the object communication lines, and also to determine the electric potential at the beginning of the earthing device, its resistance has to be calculated for the frequencies of 50 Hz, 25 kHz (main frequency of the initial lightning pulse), 1 MHz (main frequencies of the second and third lightning pulses) [1].

Human protection condition under the impact of the lightning current pulse is determined in the following way [1]:

$$R_n \int_0^T i_n^2(t) dt \leq [P], \quad (1)$$

here $i_n(t)$ – the time dependency of the current pulse flowing through the human body, A; $[P]$ – marginal permissible energy of the pulse, which does not condition the ventricular heart fibrillation, W·s; R_n – estimated electrical resistance of the human body, Ω ; T – duration of the current pulse, s.

Maximal potential, which may arise at the main potential equalization line of the object [2]:

$$U(t) = i_L(t)R_{IE} + L \cdot l \frac{di_L}{dt}, \quad (2)$$

here $i_L(t)$ – lightning current, A; R_{IE} – resistance of the earthing device; L – inductance of the earthing conductor with the length of one meter ($L \approx 1,5 \dots 2 \mu\text{H/m}$); l – length of the earthing conductor from the earthing device to the main potential equalization line.

The pulse resistance is the quantitative characteristic of the physical processes taking place during the lightning current flow through these devices. Its magnitude differs from the earthing resistance for the current of industrial frequency and depends on the parameters of the lightning current, weather conditions, presence of buildings and other objects near the earthing device, and specific ground resistance. The pulse resistance of the earthing device during the pulse peak moment has the major significance, i.e. it is approximately considered that $t = \tau_f$ (pulse front duration). The earthing devices are divided according to character of the lightning pulse current impact into [3]:

- concentrated. Their lengths are short, the inductivities do not have any significant influence for the specified soil type and lightning pulse front duration and therefore potentials at all points are practically identical;
- elongated. When calculating such earthing devices it is necessary to assess the wave-character of the propagation of voltage and current and inductivities, which increase the pulse resistance. Deep earthing devices are also attributed to this group;
- closed circuit earthing, which involve the advantages both of concentrated and elongated earthing devices.

Building earthing devices in the international lightning protection standards are classified as:

- Type A (the combination of horizontal and vertical earthings, deep earthing devices);
- Type B (ring or underlying earthing devices).

Lightning protection earthings for separately standing lightning-arresters are installed in isolation from the general earthing device of the object; in all other cases they are connected to the object's earthing device. Thus in general case we will have both concentrated and elongated earthing devices.

When discussing about the possibility to attribute the earthing to the group of concentrated earthing devices, it is offered to use the time constant of the transient process which takes place in the earthing device as the criterion:

$$T = \frac{L \cdot g \cdot l^2}{\pi^2} = \frac{L \cdot l}{\pi^2 R}. \quad (3)$$

This duration is proportional to the inductance of the entire earthing device $L \cdot l$ and its conductivity $1/R$. If $\tau_f \gg T$, the transient process quickly fades in the earthing device without lightning current reaching its maximal value. When τ_f is of the same order as T , then the pulse resistance of the earthing device during the maximum of the lightning current is $Z_i > R$. Ratio Z_i/R is called pulse coefficient.

Smallest pulse coefficient is characteristic to the earthing devices, when the minimal distance is formed between lightning current entry point and the most distant point of the earthing device. In this view it would be purposeful to construct the earthing device in the form of star-shaped polygon with minimal radius length. However the coefficient of efficiency of the earthing decreases with the increase of the number of star points, therefore the number of points is limited to four. Pulse coefficient for the concentrated earthing devices is usually less than one.

Modeling of the earthing devices

When analyzing the process of the lightning current propagation through the elements of the earthing device imitational and calculating modeling methods are applied.

However the problems of analytic calculation of parameters of earthing devices for different types of the ground and different lightning parameters are still not completely solved [2]. Certainly there are many works in which parameters of earthing devices under the impact of the pulse current of voltage are investigated [1-11].

Transient characteristics – transient resistance or transient conductivity – may be used for modeling of transient processes taking place in the earthing device in the pulse mode; these characteristics are defined as the reaction of the earthing device to the unit current impulse. Instead of the transient characteristics the pulse characteristics of the earthing devices are used: earthing device reaction to the input impact in the form of the Dirac function.

By applying the conception of the transient characteristic the expression of the earthing device voltage (current) can be written on the basis of Duhamel's integral:

$$u(t) = i(t)z(t) + \int_0^t z(t-x) \cdot i(x)dx. \quad (4)$$

The latter relation allows to calculate the $z(t)$ of the earthing device after experimental determination of the $u(t)$ and $i(t)$ vales [7], under the impact of any current pulse. This method was successfully used to describe the transient processes of the simple earthing devices.

Complex determination of the parameters of the concentrated earthing devices does not pose additional difficulties and can be implemented in the Mathcad, EMTP or Pspice program environments. When investigating the efficiency of the concentrated earthing devices for the pulse currents it is necessary to evaluate the soil ionization effects [3].

When analyzing the elongated earthing devices, most authors consider the earthing device as a long transmission line; its parameters can be determined by solving Maxwell equations:

$$\begin{cases} \oint_l \vec{E} d\vec{l} = -\frac{1}{c} \cdot \frac{d\varphi}{dt}; \\ \oint_l \vec{H} d\vec{l} = \frac{4\pi}{c} (I + I_s); \end{cases} \quad (5)$$

here c – proportion coefficient; E – electric field strength; φ – magnetic flux; H – magnetic field strength; I – conductivity current, proportional to the electric field strength \vec{E} ; I_s – electric displacement current, proportional to $\vec{\partial E} / \partial t$.

Using this method the parameters of the electric field E and magnetic field H can be determined at any point of space. The advantages of the method consist of its strictness and the possibility to obtain the frequency characteristics of the earthing device.

Other often employed view analyzes the earthing device (or its separate parameters) as a long inductive transmission line with the leakage to the ground. This view does not have any practical substantiation [4].

The third quite recently offered method links both of the earlier mentioned views. The constructional parameters of the earthing device are entered into the planar wave equations. Intermediate results are often presented as the earthing device wave resistance frequency characteristics. In the engineering practice the current or voltage pulse parameters are evaluated according to equivalent frequency

$$f_{ekv.} = 1/4\tau_f. \quad (6)$$

By using the equivalent frequency the time domain is transformed to the frequency domain.

The equivalent circuit of the long transmission line with distributed parameters is also used for electromagnetic analysis of the elongated earthing devices (Fig. 1) [5].

Conductivity g and capacitance C_i are variable magnitudes since under the high current density the electric breakdown occurs in the soil layers near the earthing devices and the radius of the earthing device sort of increases. Active longitudinal resistance of the electrodes is usually significantly less than the resistance

of the earthing device and it is not evaluated in the calculations. Calculations of the equivalent circuit parameters of the earthing device are given in [5].

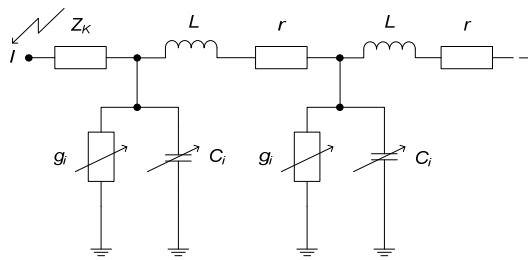

Fig. 1. The equivalent circuit of the elongated earthing device: Z_K – lightning channel resistance; L – longitudinal inductance, r – active longitudinal resistance, g_i and C_i – active pulse conductivity and capacitance of the part of the earthing device

If the lightning protection earthing device is connected to the object earthing devices then the transient characteristic of the electromagnetic wave of the latter device can be modeled using T-type equivalent circuit, which under the impact of the pulsed current would consist of longitudinal resistance R_i , inductance L_s , conductivity g_i and capacitance C_i (Fig. 2).

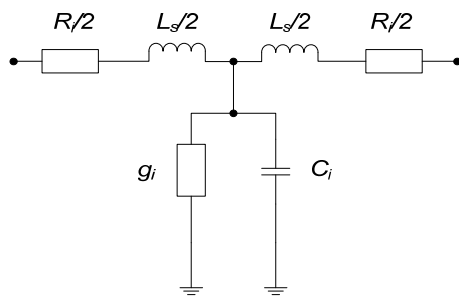

Fig. 2. The equivalent circuit of the non-lightning protection earthing device

Currently computer software of various complexity and different functionality is used to analyze the earthing devices.

Computer programs were written for the investigation of the earthing device resistance and pulse coefficient dependencies on the specific soil resistance, length of the earthing device and lightning current magnitude, separately for the vertical and horizontal earthing, with and without evaluation of the soil ionization phenomenon and dimensions of the streamer zone around the earthing device, which influence the non-linearity of the earthing device resistance. Using these programs the investigations of the earthing resistance for various soil types and electrodes of different dimensions were carried out. The determined parameters can be used for the design and calculations of the earthing devices. This is the initial part of the software, which will be used for evaluation of electromagnetic processes during the wave propagation along the conductor of the earthing system. In the result it will be possible to determine the potentials and currents at all conductive elements of the earthing and electricity supply systems.

The following assumptions were made when creating the mathematical model:

- the soil is homogenous, its specific resistance is constant;
- the influence of the magnetic field on the processes taking place inside the soil is not evaluated;
- conductive current in the soil is considerably stronger than the displacement currents ($\rho\omega\epsilon_2 \gg 1$).

The dependence of the transient process duration on the specific soil resistance ρ and the length of the earthing device l is given in Fig. 3.

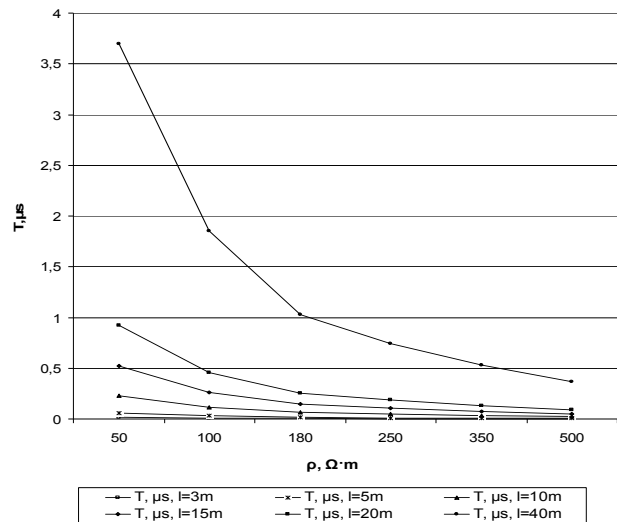

Fig. 3. The dependence of the transient process on the specific soil resistance ρ and the length of the earthing device l

It can be seen from the investigation results given in Fig. 3, that the transient processes should be evaluated for those earthing devices, the length of which exceeds 20 m and the specific soil resistance is below 300 $\Omega \cdot m$.

The dependence of the variable resistance R_{var} and pulse resistance R_{puls} on the soil specific resistance is given in Fig. 4. It can be seen from the presented data, that the difference between the variable resistance R_{var} and pulse resistance R_{puls} increases with the increase of the specific soil resistance.

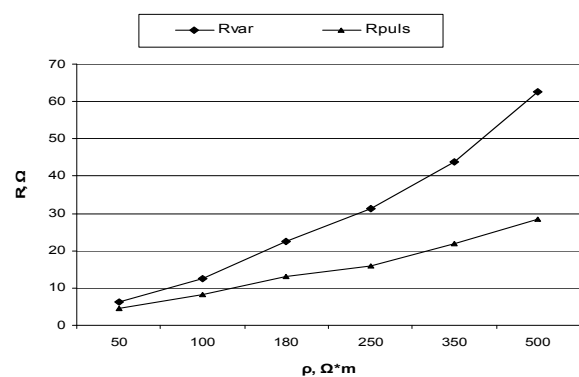

Fig. 4. The dependence of the variable resistance R_{var} and pulse resistance R_{puls} on the soil specific resistance; length of the earthing device $l=10m$, $E_{pr}=800kV/m$, $I_L=63kA$

Pulse coefficient of the elongated horizontal earthing depends on its length and the pulse current front duration

τ_f : the larger the earthing length and the shorter this duration is, the larger is the value of the α_i (Fig. 5).

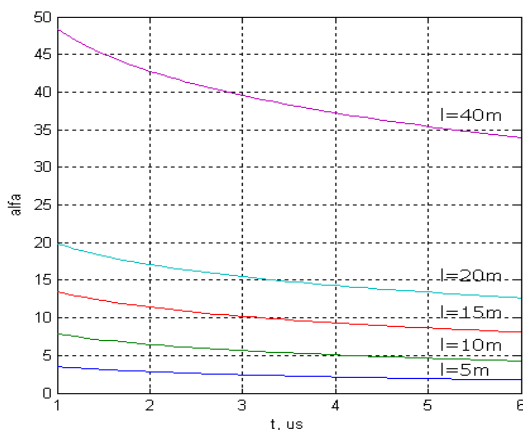

Fig. 5. Dependence of the pulse coefficient α_i on the lightning wave front duration, $\rho=250 \Omega\text{m}$

Pulse coefficient of the concentrated earthings decreases with the increase of the lightning current flowing through the earthing device and with the increase of the specific soil resistance (Fig. 6 and Fig. 7).

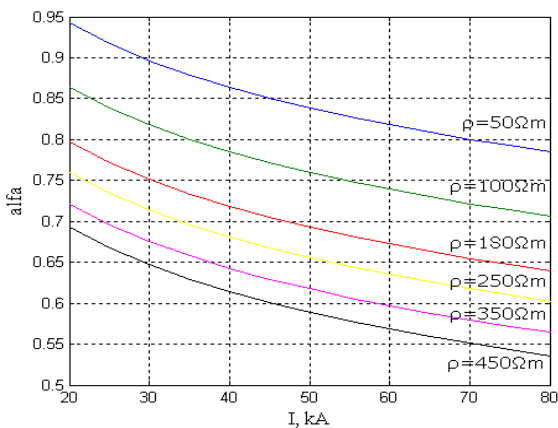

Fig. 6. Dependence of the pulse coefficient α_i of the vertical earthing on the lightning current and the specific soil resistance; earthing length $l=20\text{m}$

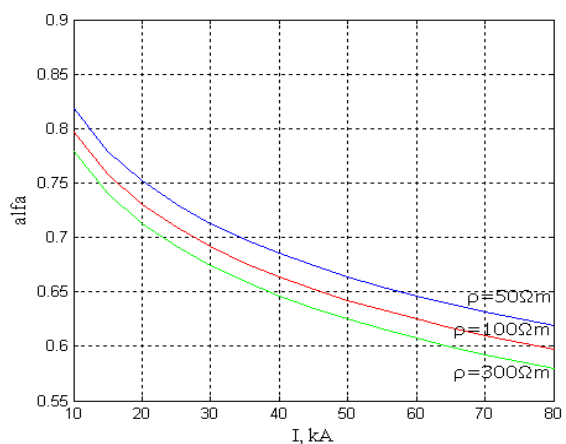

Fig. 7. Dependence of the pulse coefficient α_i of the horizontal earthing on the lightning current and the specific soil resistance; earthing length $l=20\text{m}$

Previously given modeling results do not consider the spark zones located around the earthing devices. Pulse coefficient values with respect to spark zones are given in Table 1. Model of calculations is constructed according to the method described in [5]. Coefficient values obtained by the modeling exceed the values, obtained during experimental investigations.

Table 1. The dependence of the pulse coefficient of the vertical earthing on the length of the earthing device with and without consideration of the spark process; I_L – lightning current, ρ – specific soil resistance

	$I_L = 60 \text{ kA}, \rho = 180 \Omega\text{m}$		$I_L = 60 \text{ kA}, \rho = 450 \Omega\text{m}$	
	$l=10\text{m}$	$l=20\text{m}$	$l=10\text{m}$	$l=20\text{m}$
α_i , without spark consideration	0,563	0,673	0,447	0,568
α_i , with spark consideration	1,235	1,384	1,234	1,248

Modeling of the standard earthing resistances

Constructions of the earthing devices are standardized according to the requirements specified in the building construction technical regulation STR 20106:2003 and in other standard documents, e.g. requirements of the electrical equipment installation rules are valid for the objects of electrical energetics. It is specified in the STR 20106:2003 that the resistance of the earthing devices for protection against lightning strikes in case of newly constructed buildings should not exceed 10Ω . In order to assure the lightning current flow through the ground without causing dangerous surges the construction and dimensions of the earthing system has significantly higher importance compare to the rated resistance to the current flow of the separate electrode. Not less than two earthing electrodes have to be used in the earthing device for the better lightning discharge current flow. However it is still recommended to use small resistances for the earthing of the lightning current.

The diagrams of the earthing devices proposed by republic building construction standards RSN 139-92 are given in Table 2.

In order to determine the suitability of the offered earthing devices for the lithuanian conditions (specific soil resistance varies in the range of $10 \Omega\cdot\text{m} - 7000 \Omega\cdot\text{m}$), the modeling of the dependency of the pulse resistance on the flowing lightning current magnitude and on the specific soil resistance was performed.

Calculations of the horizontal three-point earthing device ($l = 8 \text{ m}$.) are given in Fig. 8. Dependency of the pulse resistance on the lightning current was calculated for two cases: when the earthing device consists of horizontal electrodes only and when the earthing device consists of horizontal and vertical groundings.

As it can be seen from the obtained characteristics, the installation of the vertical electrodes considerably decreases the pulse resistances of the earthing device. Such earthing is effective in the entire lightning current variation range. Meanwhile the horizontal earthings alone can be effective in the soils of high specific resistance under the flow of strong lightning currents.

Table 2. Constructions of the earthing devices according to RSN 139-92

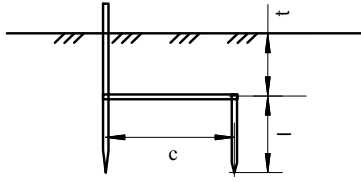
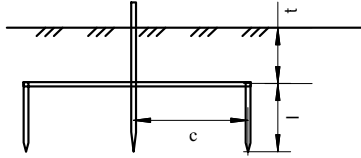
Earthing device	Sketch	Dimensions, m.	Comments
Two steel rods: width of the bar 40x4 mm; diameter of the rods $d = 10-20$ mm.		$t \geq 0,5$ $l = 3-5$ $c = 3-5$	As it is defined by the authors of RSN 139-92, in this table the constructions of the earthing devices are given which satisfy the resistances R_i when the lightning current alternates from 5 to 100 kA.
Three steel rods: width of the bar 40x4 mm; diameter of the rods $d = 10-20$ mm.		$t \geq 0,5$ $l = 3-5$ $c = 3-5$	

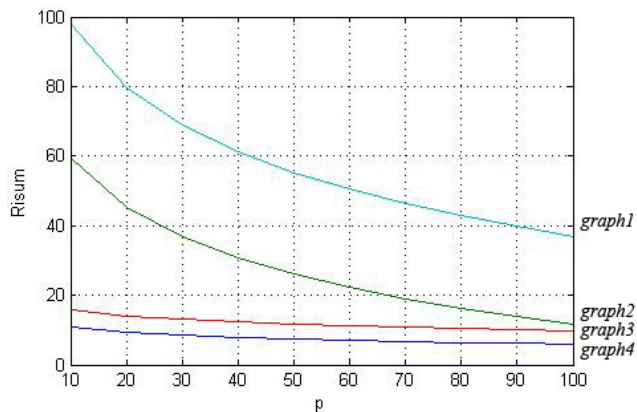

Fig. 8. The dependency of the pulse resistance of the three-point horizontal earthing on the lightning current; *graph1* – $\rho=300 \Omega\cdot\text{m}$, *graph2* – $\rho=3000 \Omega\cdot\text{m}$, *graph3* – $\rho=300 \Omega\cdot\text{m}$ with vertical electrodes, *graph4* – $\rho=3000 \Omega\cdot\text{m}$ with horizontal electrodes

The dependence of pulse resistances of the earthings with two and three vertical electrodes on the specific soil resistance is presented in Fig. 10. As it can be seen from these graphs, pulse resistance of 10Ω can be achieved with all earthing devices under lightning currents above 30 kA.

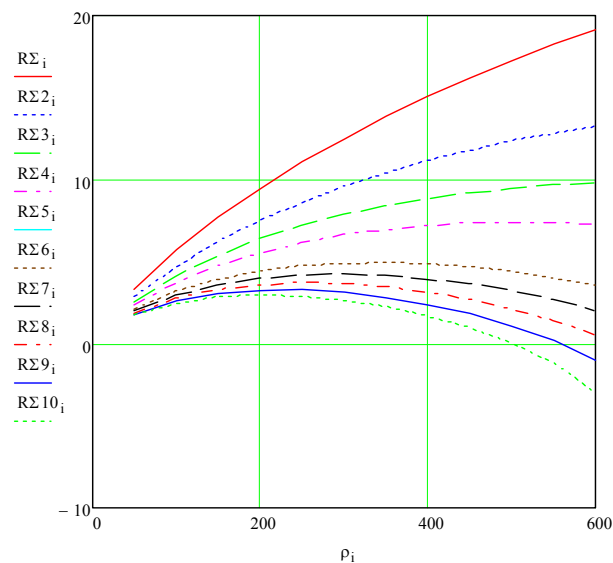

Fig. 9. Dependency of the resistance of the vertical earthings on the specific soil resistance

Generally it can be stated that some certain marginal length l exists for the earthing devices which depends on the specific soil resistance, lightning current magnitude and sharpness of its front. When the length of the electrode is increased even more, the further reduction of the pulse coefficient α_i can not be achieved. It is purposeful to use such earthing devices the spark coefficient of which is $\alpha_i \leq 1$.

Accumulated experience in the field of design and exploitation of the earthing devices and conducted experimental works permits recommendation of the following types of earthing devices:

- in soils of $\rho < 300 \Omega\cdot\text{m}$ it is purposeful to use the concentrated vertical groundings of the length of 2,5-3 m. When lower layers of the soil have high conductivity, the electrode length is increased up to 4-6 m.;
- when upper soil layer has high conductivity, it is purposeful to use horizontal electrodes the length of which starts from 8 m.;
- in soils of $\rho \geq 400-3000 \Omega\cdot\text{m}$ the combined earthing is optimal, for example consisting of 2-3 horizontal points and vertical electrodes 2,5-3 m long. In this case the electrode shielding should be considered, therefore it is not recommended to set the vertical electrodes near each other. The distance between the vertical electrodes should be not less than the double electrode length.;
- in soils of $\rho \geq 800 \Omega\cdot\text{m}$ it is purposeful to use pointed earthing devices, the points of which have the length of 20-40 m. In critical cases ring-shaped long earthings can be used.

Conclusions

The computer program was created for the investigations of the earthing resistances and pulse coefficient. Using this program the dependences of the resistances of the vertical and horizontal earthings on the specific soil resistance and dimensions of the earthing device were determined.

It was determined during the modeling that the pulse resistance of the earthing decreases exponentially with the increase of the lightning current.

During analysis of the computer modeling results it was determined, that theoretical calculations are closest to the experimental results when the spark process around the earthing device is not evaluated.

It was determined by calculations that with the increase of lightning current from several tens to several hundreds of amperes the value of R_i can decrease from 2 to 5 times.

References

1. **Карякин Р. Н.** Нормативные основы устройства электроустановок. – Монография. – Москва. – 1998. – 237 с.
2. **Базелян Э. М., Райзер Ю. П.** Физика молнии и молниезащиты. – Москва: Физматлит, 2001. – 320 с.
3. **Рябкова Е. Я.** Заземления в установках высокого напряжения. – Москва: Энергия, 1978. – 225 с.
4. **Базуткин В. В. и др.** Оценка параметров заземлителей при воздействии импульсных токов // *Электричество*. – 2002. – № 6. – С. 6–12.
5. **Анненков В. З.** Протяженные заземлители молниезащиты в грунтах с нелинейными вольт–амперными характеристиками // *Электричество*. – 2001. – № 6. – С. 22–29.
6. **Baublys J., Gudžius S., Jankauskas P., Markevičius L., Morkvėnas A.** Žaibas. Apsauga nuo žaibo. – Monografija. – Vilnius. – 2006. – 231 p.
7. **Christopoulos Ch., Wright A.** Electrical Power System Protection. – Kluwer. – 1999. – 607 p.
8. **Gudžius S., Markevičius L.** Elektromagnetinių procesų baziniai skaitmeniniai procesai // *Elektrotechnika* 21(30): mokslo darbai. – Kaunas: Technologija, 1997. – P. 126–130.
9. **Arrillaga J., Watson N. R.** Computer Modelling of Electrical Power Systems. 2nd Editon. – John Wiley & Sons. – 2001. – 369 p.
10. **Anderson P. M., Fouad A. A.** Power System Control and Stability. – Wiley – IEEE Press. – 2002. – 672 p.
11. **Bagdanavicius N., Drabatiukas A., Kilius S.** Parameters of Lightning Current in Lightning Protection Calculations // *Electronics and Electrical Engineering*. – Kaunas: Technologija, 2009. – No. 3(91). – P. 103–106.

Received 2009 04 17

N. Bagdanavičius, D. Eidukas, A. Drabatiukas, Š. Kilius. Modeling of Parameters of Building Earthing Devices // Electronics and Electrical Engineering. – Kaunas: Technologija, 2009. – No. 6(94). – P. 51–56.

When researching the process of the lightning current propagation through the elements of the earthing device imitational and computational modeling methods are used. The computer program was created for the investigation of the dependences of the earthing resistances and pulse coefficient on the specific soil resistance, length of the earthing device and lightning current magnitude. Using this program earthing resistance investigations were accomplished for various soil types and electrodes of different dimensions. Determined parameters are suitable for the design and calculations of the earthing devices. Ill. 9, bibl. 11 (in English; summaries in English, Russian and Lithuanian).

Н. Багданавичюс, Д. Эйдукас, А. Драбатюкас, Ш. Килиус. Моделирование параметров заземлителей зданий // Электроника и электротехника. – Каунас: Технология, 2009. – № 6(94). – С. 51–56.

Исследования процесса распространения тока молнии по элементам заземляющих устройств проводится при помощи имитационных и расчетных методов моделирования. Для исследования зависимостей сопротивления и коэффициента импульса заземлителей от удельного сопротивления грунта, длины заземлителя и тока молнии создана компьютерная программа. С помощью программы выполнены исследования заземлителей для различных грунтов и для разных размеров электродов. Найденные параметры пригодны для расчета и проектирования заземлителей. Ил. 9, библи. 11 (на английском языке; рефераты на английском, русском и литовском яз.).

N. Bagdanavičius, D. Eidukas, A. Drabatiukas, Š. Kilius. Pastatų įžemintuvų parametrų modeliavimas // Elektronika ir elektrotechnika. – Kaunas: Technologija, 2009. – Nr. 6(94). – P. 51–56.

Tiriant žaibo srovės sklaidimo įžeminimo įrenginio elementais procesą taikomi imitaciniai ir skaičiuojamieji modeliavimo metodai. Įžemintuvo varžų ir impulso koeficiento priklausomybė nuo grunto savitosios varžos, įžemintumo ilgio ir žaibo srovės stiprio tirti sudaryta kompiuterio programa. Naudojantis programa atlikti įžeminimo varžos tyrimai esant įvairiems gruntams ir įvairių matmenų elektrodams. Nustatyti parametrai tinka įžemintuvams skaičiuoti ir projektuoti. Il. 9, bibl. 11 (anglų kalba; santraukos anglų, rusų ir lietuvių k.).