

Electrical Circuit Model of Fractional Flow Reserve in Cerebrovascular Disorders

H. Pranevicius^{1,2}, D. Naujokaitis¹, V. Pilkauskas¹, O. Pranevicius³, M. Pranevicius⁴

¹*Department of Informatics, Kaunas University of Technology,
Studentu St. 56-301, LT - 51424 Kaunas, Lithuania*

²*Faculty of Informatics, Vytautas Magnus University*

³*Hospital Queens Fleshing,
NY, USA*

⁴*Albert Einstein College of Medicine,
NY, USA*

henrikas.pranevicius@ktu.lt

Abstract—We developed electrical circuit based model for the different components of the cerebral circulation, what allowed us to simulate cerebral blood flow in a variety of cerebrovascular disorders. This approach allowed us to derive a set of equations by which relative maximum, or fractional flow reserve, can be defined and calculated in three relevant sites: the stenotic artery, in the veins related to the stenotic artery, and in the collateral circulation of the affected region of the brain.

Our results create theoretical basis for the entirely new approach to cerebrovascular disorders that currently emphasise anatomical identification of the disease to guide the treatment, such as the degree of arterial luminal stenosis obtained from various imaging modalities. In doing so, we directly address an urgent need for stroke experts to advance the care of their patients, since current approach of stroke treatment has not been meaningfully successful.

Index Terms—Cerebral blood circulation, hybrid system, piece-linear aggregates, Starling resistor.

I. INTRODUCTION

Cerebrovascular occlusive disease (COD) remains one of the most widespread diseases amongst humans, and its extreme expression - stroke, still remains one of the primary causes of the morbidity and mortality. Current, outmoded approach to cerebrovascular disorders heavily relies on the anatomical identification and quantification of the disease to guide the treatment. Unfortunately, despite millions of cases around the world, the results of the current approach have been dismal. This state of affairs can only change with a full understanding of how stenosis of the cerebrovascular vasculature can be defined in the terms of its geometric dimensions, pressure gradient-flow relations, resistances of inflow, outflow, and collateral vessels, and regional fractional flow reserve (rFFR), or maximum flow capacity. Only then the endeavours might be undertaken for the development of our ability to quantify and affect that

reserve.

In this paper, we have simulated physiological and pathophysiological processes of the cerebrovascular occlusion using equivalent electric circuits, and investigated bearing of this technique for the diagnosis of rFFR in COD. We showed that hemodynamic measurements, distal to the stenosis provide the ability to quantify the overall results of a stenosis on cerebral perfusion and the state of the cerebral microcirculation. Moreover, it allows the study of the interaction between cerebral outflow and cerebral inflow dynamics. We showed that the developments in the regional perfusion measurements are expected to be a major step forward in bringing physiology to the clinical arena since not only diminution of blood flow, but also regional differences of blood flow are induced by the stenosis. These regional differences are not only present between perfusion territories distal of obstructed and normal brain arteries but also within and between these territories, especially when the collateral flow is possible.

Model developments allow the integration of all of these measurements at the regional level, all derived from pressure and flow data, provided by the whole brain perfusion imaging, such as 4D CT scanning.

In addition to the integration of data, the computational frameworks presented here will enable the simulation of individual entities such as specific artery occlusion or microvascular disease, and the analysis of physiological mechanisms – such as the role that central venous pressure plays on regional distribution of the cerebral flow. Our goal is to provide more complete picture of the cerebral blood flow physiology in normal and diseased brain conditions and to enhance differentiation and personalisation for the diagnostic and treatment purposes.

II. CEREBRAL BLOOD FLOW MODELLING USING ELECTRICAL CIRCUIT

We adapted model of collateral cerebral blood flow [1], [2] to estimate Fractional Cerebral Blood Flow Reserve (fCBFR) as described for coronary circulation by Pijls [3]

Manuscript received January 26, 2014; accepted May 24, 2014.

This work was supported by the Research Council of Lithuania for collaboration Lithuania and USA scientists under the grant MIT-074/2012.

(Fig. 1). Collateral source (resistors R1, R4) was connected to ischemic region (resistors R2, R5) via collateral pathway (resistor R3). We assumed that arterial pressure P_a is the same inflow pressure for both ischemic region and collateral source, and venous pressure P_v is the same outflow pressure for both pathways. Blood flow restriction by increased tissue pressure was simulated using modified Starling resistors R4 and R5 with external pressures P_1 and P_2 [4]. Ischemia was simulated by increased inflow resistance R2. Absence of auto regulation due to maximal vasodilation was presumed.

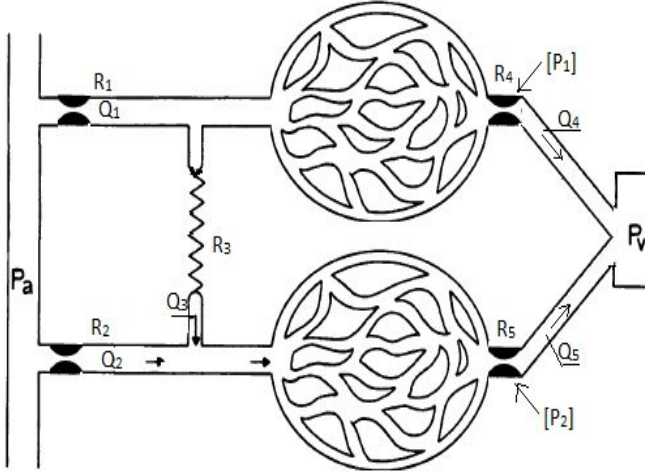

Fig. 1. Schematic representation of cerebral collateral circulation.

Ischemic region (Fig. 1) has increased inflow resistance R2 and outflow resistance R5, which depends on external tissue pressure P2. Parallel collateral source has inflow resistance R1 and outflow resistance R4 which depends from the tissue pressure P1. Inflow/outflow intersection is considered collateral connection R3 take-off point in the collateral source and collateral connection supply point in the ischemic region. Arterial pressure P_a is the same inflow pressure for both pathways and Venous pressure P_v is the same outflow pressure for both pathways.

Electrical circuit analog of the collateral circulation is presented in Fig. 2

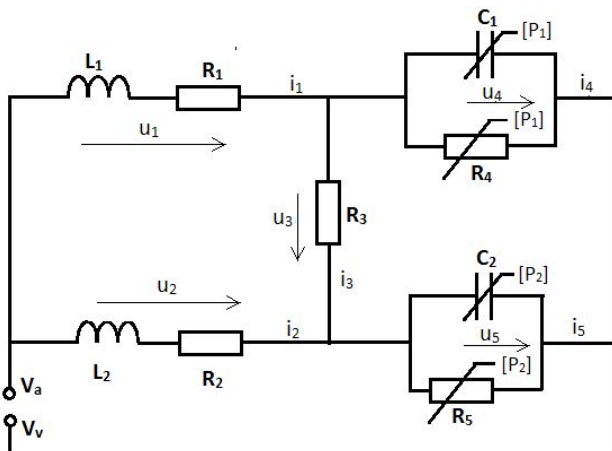

Fig. 2. Electrical circuit analog of collateral cerebral blood flow.

In Fig. 2 inflow and outflow pressures represented by voltage V_a and V_v , current represents flow and charge represents cerebral blood volume. Collateral source inflow is represented by inductivity L1 and resistor R1; outflow is

represented by Starling resistor R4 and nonlinear capacitor C1. Inflow of ischaemic region is represented by L2 and R2, outflow by Starling resistor R5 and nonlinear capacitor C2. Collateral connection is represented by resistor R3.

Starling resistor R is described by following equation

$$R(u_i, u_o, P_j) = \begin{cases} R_0, & U_s(u_i, u_o, P_j) = 0 \\ & \wedge (P_j < u_i \vee P_j < u_o), \\ \infty, & U_s(u_i, u_o, P_j) = 0 \\ & \wedge P_j > u_i \wedge P_j > u_o, \\ \frac{R_0(u_i - u_o)}{U_s(u_i, u_o, P_j)}, & U_s(u_i, u_o, P_j) > 0, \end{cases} \quad (1)$$

where R_0 is selected minimum value of Starling resistance R , when external pressure is equal zero, \wedge, \vee is AND, OR operators. u_i, u_o, P_j are inflow, outflow and external pressure respectively, j is index of external pressure $j = \overline{1, 2}$. Function $U_s(u_i, u_o, P_j)$ describes transmural pressure of blood vessel (2)

$$U_s(u_i, u_o, P_j) = (u_i - u_o)H(u_i, P_j)H(u_o, P_j) + (u_i - P_j)H(u_i, u_o)H(P_j, u_o)H(u_i, P_j) + (P_j - u_o)H(u_o, u_i)H(P_j, u_i)H(u_o, P_j), \quad (2)$$

where H is the Heaviside function (3)

$$H(x, y) = \begin{cases} 0, & x - y < 0, \\ \frac{1}{2}, & x - y = 0, \\ 1, & x - y > 0. \end{cases} \quad (3)$$

Nonlinear capacitance C incorporates transmural pressure / volume relationship of the blood vessels, which generally has sigmoid, nonlinear form [1], [5]. Variable capacitance C and electrical charge Q is described by (4) and (5), respectively:

$$C(U_s) = \frac{Q_0 k e^{-k U_s}}{(1 + e^{-k U_s})^2}, \quad (4)$$

$$Q(U_s) = \frac{Q_0}{1 + e^{-k U_s}}, \quad (5)$$

where Q_0 represents maximal blood volume, capacitance $C(U_s)$ is describing transmural pressure-blood volume relationship differential, k – is slope constant. $Q(U_s)$ is blood volume dependence on transmural pressure.

Cerebral blood flow is dynamic system that exhibits both continuous and discrete dynamic behaviour. For simulation of distribution of the blood flow between compartments we used hybrid systems simulation method based on PLA

formalism [6].

For realization of hybrid aggregate model Quantized State System (QSS) method is used [7], [8]. For creation of hybrid aggregate imitators we used PLASim simulation library [9].

The PLASim is an object-oriented library for discrete-event simulation of models created using aggregate formalism. The PLASim's current version written in C# for NET Framework 4.0 and has packages that support random number generation, statistical collection, basic reporting with data visualization and discrete-event simulation. The development of a simulation model is based on sub-classing the SimulationModel class that provides the primary recurring actions within a simulation and event scheduling and handling. The user adds developed aggregates (model elements) based on sub-classing the Aggregate class, to an instance of Model and then executes the simulation.

III. ELECTRICAL CIRCUIT TRANSFORMATION TO BLOCK SCHEMA

Currently a variety of program packages are utilized to model electric circuits, such as Micro-Cap, Simulink and others. However these packages lack flexibility in adequately describing nonlinear elements of the circuit. In an attempt to overcome this limitation, we used modelling system that based on a hybrid aggregate formalism [4][6]. This allowed us to transform electric circuit of interest into the block-scheme of corresponding aggregates whose main components are integrators, summatoms, multipliers, and functional blocks.

Because universal method to transform electrical circuit into such block-schemes [7] does not exist, the transformation has to be accomplished on a case by case basis, taking into account structure of the electrical circuit and it's complex relationships between the currents and potential differences. We illustrated corresponding components and their connections in our case – resistances R, inductivity L, capacitance C, current i and potential difference u relationships (Fig. 3).

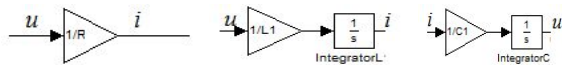

Fig. 3. Elements of block scheme.

Building of the block-scheme, that is equivalent to the branch of electric circuit consisting of the inductivity L1 and the resistance R1, is accomplished in several steps. Because elements connect consecutively, the same current i_1 passes through them all, what is expressed in a parallel connected elements of the equivalent block-scheme (Fig. 4). In the other branch of the electric circuit i_4 , resistance R4 and capacitance C1 connect in parallel, hence potential difference u_4 falling on them both is the same, what is reflected in parallel connected corresponding elements in the block-scheme.

On these principles a block scheme was built, which is equivalent (to Fig. 1 and Fig. 2) to the functional unit of the cerebral circulation that has inflow, two parallel outflow pathways, and a collateral between them. This configuration is similar to configuration used in cardiology for the study of functional flow reserve.

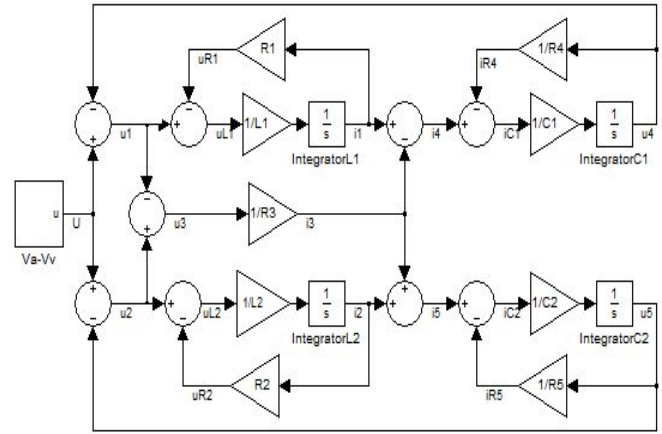

Fig. 4. PLA equivalent of electric circuit.

IV. SIMULATION RESULTS

We simulated flow distribution between collateral pathway and ischaemic region with variable degree of stenosis at the inflow of the ischaemic region ($R_2 = 100, 200, 500, 1000, 2000$) and variable outflow obstruction ($P_2 = 0, 20$).

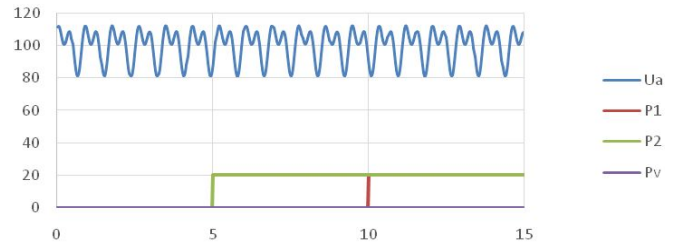

Fig. 5. Loading conditions that were simulated – arterial pressure U_a , external pressures P_1 and P_2 and venous pressure P_v .

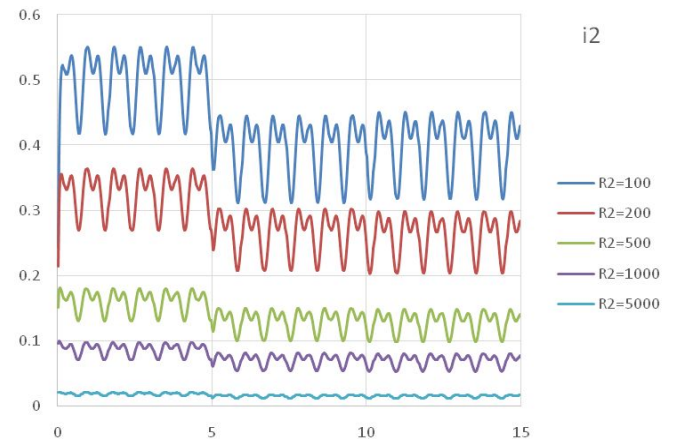

Fig. 6. Inflow reduction when increasing resistance R_2 (one arterial branch is partially occluded) and flow redistribution when increasing external pressure (development of post stroke edema).

Other parameters:

Collateral inflow resistance: $R_1 = 100$, Collateral and ischaemic outflow resistance (without collapse): $R_4 = R_5 = 100$. Collateral connection resistance: $R_3 = 800$. Venous pressure: $P_v = 0$;

A brachial arterial pressure pulse serves as input to the entire model (Fig. 5). This pulse modelling by equation [10]

$$P_a(t) = \text{MAP} + A_0 \sin(2f \frac{f_{hr}}{60} t) + A_1 \sin(4f \frac{f_{hr}}{60} t + w_1), \quad (6)$$

where mean arterial pressure $\text{MAP} = 100$ mmHg, $A_0 =$

10 mmHg, $A_1 = 9$ mmHg, $f_1 = 1.2$ radians. f_{hr} - heart rate (60 min–90 min, default 70 min). Simulation results are represented in Fig. 6–Fig. 8.

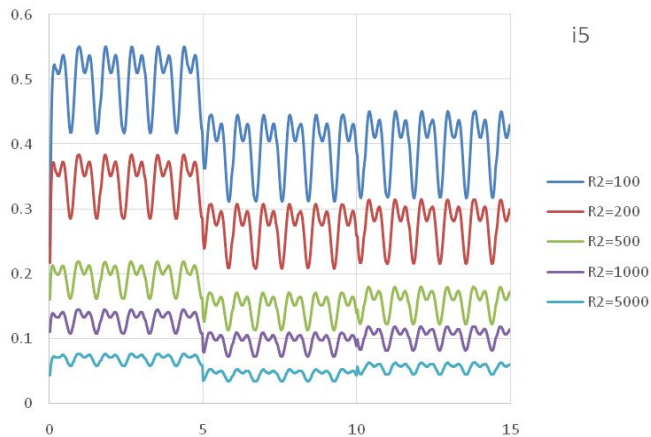

Fig. 7. Outflow i_5 in the ischemic region via R5C2P2. As inflow resistance increases 50 times, outflow decreases about 10 times. As P2 increases from 0 to 20 (after 5 seconds), the flow drops. This drop is partially reversed when P1 increases from 0 to 20 at 10 seconds, although here the reversal is minor because the collateral supply is relatively small.

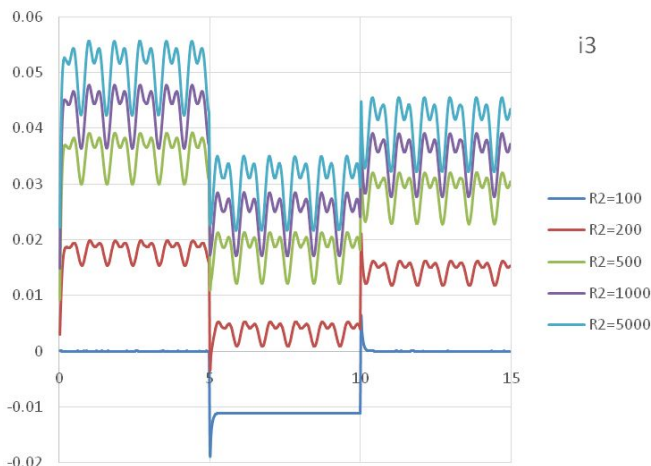

Fig. 8. Flow through collateral connection R3. Figure illustrates that flow becomes negative (development of steal), when the external pressure in ischemic region exceeds pressure in collateral source (period from 5 to 10 seconds).

V. CONCLUSIONS

PLA simulation of the electrical circuit representing collapsible cerebral circulation allowed to obtain dynamic pressure/flow distribution between ischaemic area and collateral source. All these simulated flows can be easily recorded with current medical equipment in real situations.

Using this theoretical framework inflow stenosis can be

calculated as a fractional cerebral blood flow reserve. Additionally, the effects of locally increased tissue pressure from the post-stroke edema can also be described in terms of fractional flow reserve and the dependency of this reserve from a variety of inflow, outflow and collateral flow conditions. Hence, the proposed theoretical framework allows the most adequate characterisation of arbitrary cerebral ischemic region for any given diagnostic, therapeutic and research purpose: It allows to characterise each given ischemic region as a sum of its three pathophysiological components – the degree of disturbance of inflow, the degree of disturbance of outflow, and the degree of collateral failure.

REFERENCES

- [1] O. Pranevicius, M. Pranevicius, H. Pranevicius, D. S. Liebeskind, "Transition to collateral flow after arterial occlusion predisposes to cerebral venous steal", *Stroke*, vol. 43, pp. 575–579, 2012. [Online]. Available: <http://dx.doi.org/10.1161/STROKEAHA.111.635037>
- [2] O. Pranevicius, M. Pranevicius, D. Liebeskind, "Partial aortic occlusion and cerebral venous steal: venous effects of arterial manipulation in acute stroke", *Stroke*, pp. 1478–1481, 2011. [Online]. Available: <http://dx.doi.org/10.1161/STROKEAHA.110.603852>
- [3] N. H. Pijls, J. A. van Son, R. L. Kirkeeide, B. De Bruyne, K. L. Gould, "Experimental basis of determining maximum coronary, myocardial, and collateral blood flow by pressure measurements for assessing functional stenosis severity before and after percutaneous transluminal coronary angioplasty", *Circulation*, vol. 87, pp. 1354–1367, 1993. [Online]. Available: <http://dx.doi.org/10.1161/01.CIR.87.4.1354>
- [4] H. Pranevicius, D. Naujokaitis, V. Pilkauskas, O. Pranevicius, M. Pranevicius, "Modelling and simulation of regional Cerebral Circulation", in *Proc. Int. Conf. Bioinformatics and Computational Biology*, Las Vegas, Nevada, 2013, pp. 279–284.
- [5] S. A. Berger, "Flow in large blood vessels", *Fluid Dynamics in Biology, Contemporary Math. Series*, pp. 479–518, 1992.
- [6] H. Pranevicius, L. Simaitis, M. Pranevicius, O. Pranevicius, "Piece-linear aggregates for formal specification and simulation of hybrid systems: pharmacokinetics patient-controlled analgesia", *Elektronika ir Elektrotechnika*, nr. 4, pp. 81–84, 2011.
- [7] H. Pranevicius, T. Kraujalis, "Piece Linear-Aggregate Approach for Modelling and Analysis of Fuzzy Systems", *Elektronika ir Elektrotechnika*, vol. 19, no. 1, pp. 73–76, 2013. [Online]. Available: <http://dx.doi.org/10.5755/j01.eee.19.1.3261>
- [8] E. Kofman, "Discrete event simulation of hybrid systems", *SIAM Journal on Scientific Computing*, no. 25, pp. 1771–1797, 2004. [Online]. Available: <http://dx.doi.org/10.1137/S1064827502418379>
- [9] G. Guginis, V. Pilkauskas, "The system for generating simulation model code from the PLA specifications", in *Proc. 14th Int. Conf. Information and Software Technologies, (IT 2008)*, Kaunas, Lithuania, 2008, pp. 101–109.
- [10] G. Drzewiecki, R. Hood, H. Apple, "Theory of the oscillometric maximum and the systolic and diastolic detection ratios", *Annals of Biomedical Engineering*, vol. 22, pp. 88–96, 1994. [Online]. Available: <http://dx.doi.org/10.1007/BF02368225>