

Magnetic Field Simulation in Embedded System with Magneto-Resistive Sensor

V. Markevicius, D. Navikas, M. Cepenas

Department of Electronics Engineering, Kaunas University of Technology,

Studentų str. 50, LT-51424 Kaunas, phone: +37037300522, e-mail: dangirutis.navikas@ktu.lt

crossref <http://dx.doi.org/10.5755/j01.eee.115.9.760>

Introduction

Anisotropic magnetoresistive (AMR) sensors are widely used in different applications [1, 2] for detection of the Earth or other objects magnetic field weak changes. AMR sensor can be used to measure DC and AC current by sensing the field near the conductor in a contactless way [3] or vehicle predictive crash detection [4]. These sensors are very sensitive to temperature changes [5] and parasitic magnetic fields. This raises the natural question – what influence makes components of embedded system to AMR sensor? All components of the system that can be magnetized or produces magnetic field has influence on sensor. That could be controller, inductors of DC/DC converter, LED drivers (Fig. 1), data buss, power wires and etc. Even though most of the modern controllers and AMR sensors require little current, but network of 100 units may consume 3 to 10 A.

Magnetic field sensor attached to active network (RS485 buss) was chosen for modeling. Sensors are connected to a single power supply wire (in series).

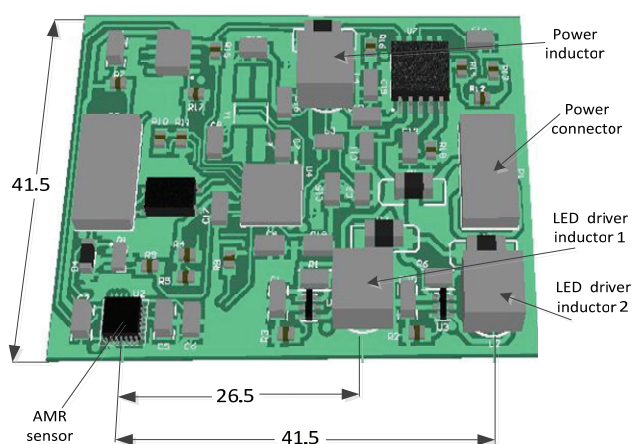

Fig. 1. Embedded system with AMR sensor. PCB layout

The Finite Element Method (FEM) using Comsol

Multiphysics is widely used for modeling of magnetic and electric fields. This method was used for Simulations of LED driver inductors and DC/DC power converter inductor, Calculations of power and RS486 line magnetic field flux. These coils and lines were modeled in 3D using the AC/DC Module-Statics and Magnetic of Comsol. We made a magnetic static analysis to generate a magnetic flux density in environment of coils and lines.

The governing equation for modeling of inductors and lines under steady state conditions is [6]:

$$\begin{cases} \nabla \times (\mu_r^{-1} \mu_0^{-1} \nabla \times \mathbf{A}) + \sigma \nabla V = 0, \\ -\nabla \cdot (\sigma \nabla V) = 0, \end{cases} \quad (1)$$

where σ is the electric conductivity, V is the voltage throughout the model, and \mathbf{A} is the magnetic vector potential, which defines \mathbf{B} , the magnetic flux density. Equation (1) is shown under the assumption that there is no bulk motion and all current flow is excited via the boundaries. All domain settings are specified via the *Materials* branch, so only boundary conditions need to be applied.

Modeling of inductors

Models for two types of inductors were created – open and closed core (Fig. 2).

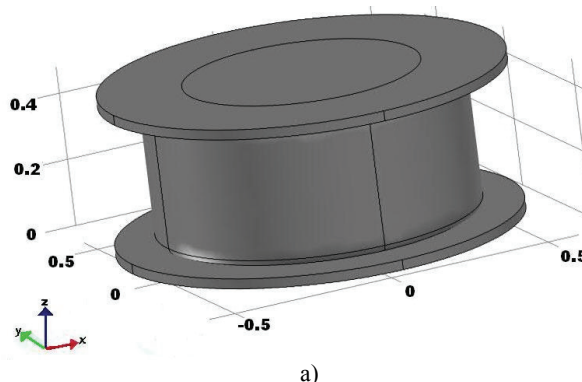

a)

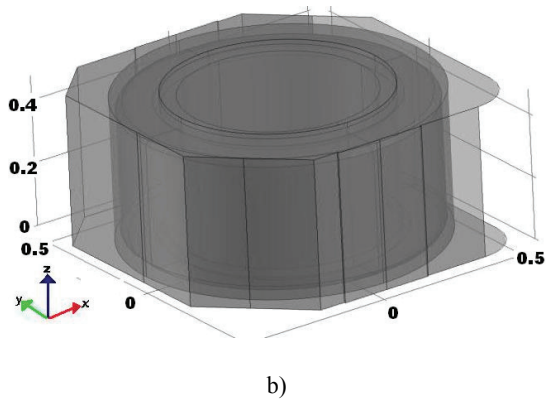

Fig. 2. Comsol models of inductors: a) open core; b) closed core

Initial parameters of models are presented in Table 1.

Table 1. Initial parameters of models

| Parameter | Closed core | Open core |
|--------------------|-------------|-------------|
| Number of windings | 26 | 83 |
| Current | 1 A | 1 A |
| Coil thickness | 1.3 mm | 1.3 mm |
| Coil height | 4.2 mm | 4.2 mm |
| Core diameter | 7 mm | 7 mm |
| Inductance | 332 μ H | 335 μ H |

Modeling results are presented in Fig. 3 and Fig.4.

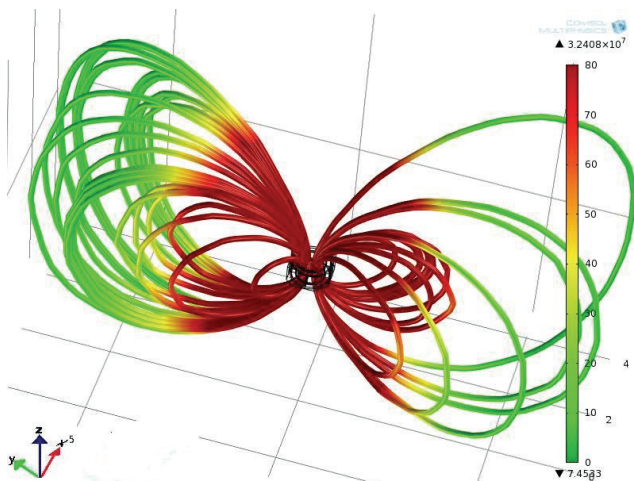

Fig. 3. Closed core inductor magnetic field magnitude (Comsol simulation)

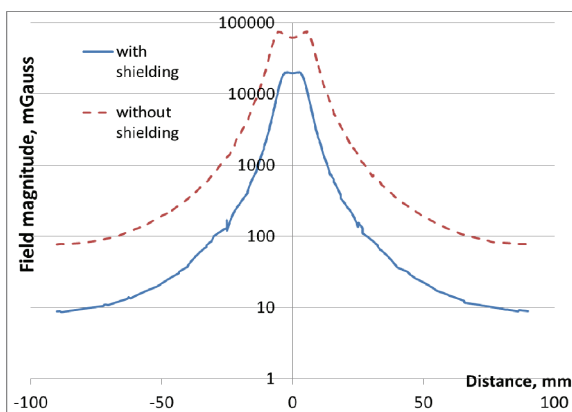

Fig. 4. LED inductors magnetic field magnitude versus distance (Comsol simulation data)

These figures show that in open core inductors case, in 90 mm distance there is 90 mGauss magnetic field magnitude, which is around 10% of Earth magnetic field magnitude. Using closed core inductors, magnetic field magnitude in the further zone is 10 times less than in an open core inductor case.

Power and RS485 line modeling

Power and RS485 lines are designed with 6.5 mm gap between each other. Their parameters are presented in Table 2. Models of PCB traces are shown in Fig. 5.

Table 2. Initial parameters of models

| Parameter | Power | RS485 |
|---------------------|---------|---------|
| Current | 3 A | 0.5 A |
| Conductor thickness | 0.05 mm | 0.05 mm |
| Conductor width | 1 mm | 1 mm |
| PCB thickness | 1.6 mm | 1.6 mm |
| Line width | 5 mm | 5 mm |

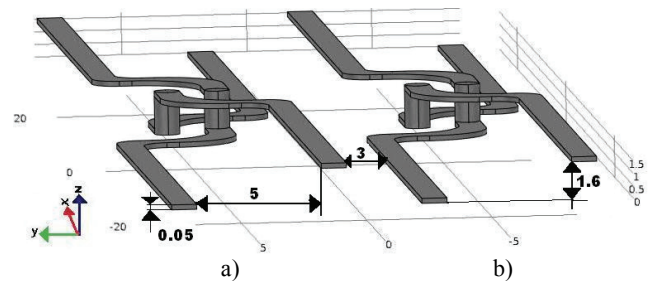

Fig. 5. Comsol models of PCB traces: a) RS485; b) power line

It can be seen that 5 mm gap between conductors of lines are not optimal considering induced magnetic field. However, the connections used in construction (MULTICOMP - PA001-2 - TERMINAL BLOCK, PCB, 2WAY, VERTICAL) have the step of 5 mm and another gap is impossible in this case.

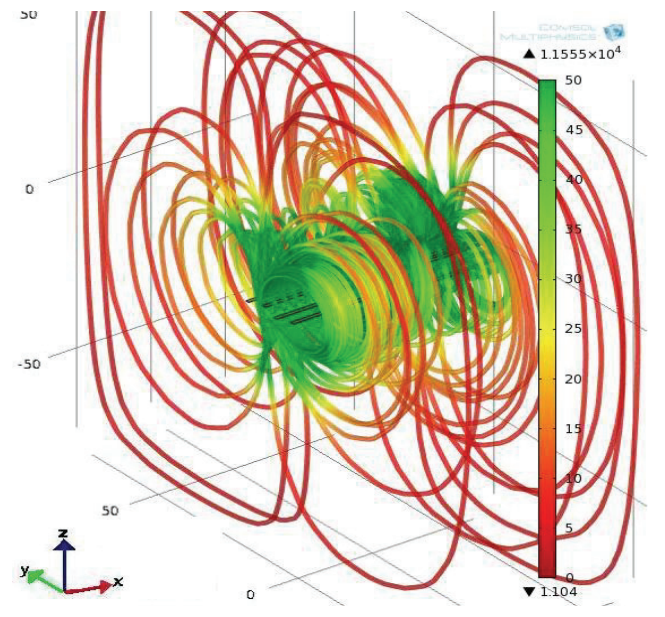

Fig. 6. RS485 and power line magnetic field magnitude (Comsol simulation)

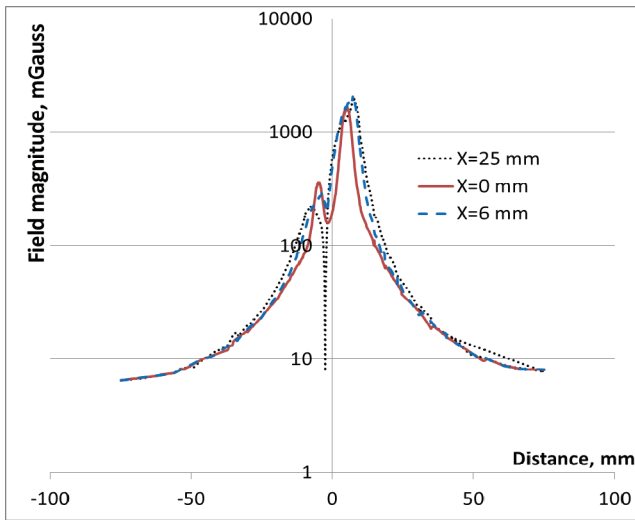

Fig. 7. Twisted in center RS485 & Power line magnetic field magnitude. Y-Z plane, Z=1.5 mm

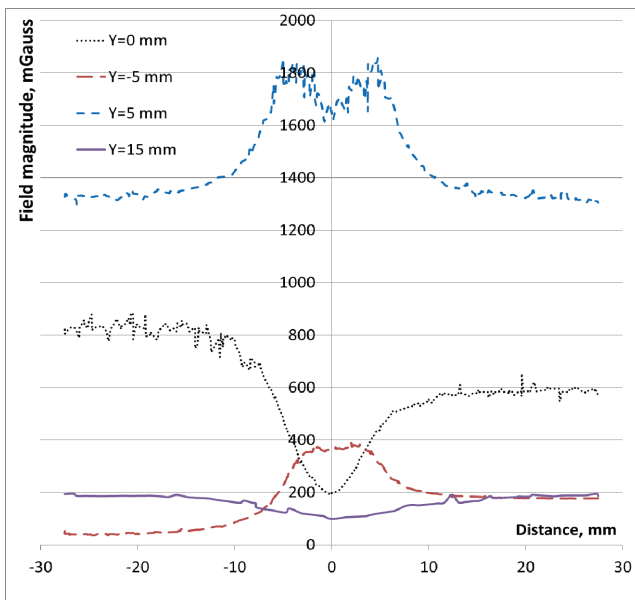

Fig. 8. Twisted in center RS485 & Power line magnetic field magnitude. X-Z plane, Z=1.5 mm

The results show that in the case of twisted power line, the influence of current can be reduced up to 1000 times in the line center, and up to 10 times in a 40–50 mm distance. Therefore, it can be seen from Fig.7 that in a distance of 50 mm or more the influence of twisting is minimal and highest influence to magnetic field strength is made by the separation of wires.

Experimental investigation

The magnetic field probe (Fig. 9) and data acquisition device using ATMEL microcontroller AT90USB1287 (Fig. 10) were designed and produced for experiments.

Data acquisition device was connected to laptop by USB. The data from magnetic field sensor were captured to file using created software. This software allowed recording the data of sensors in set frequency (from 10 times per second up to once a day). The probe was positioned above PCB components (inductors, data and power lines).

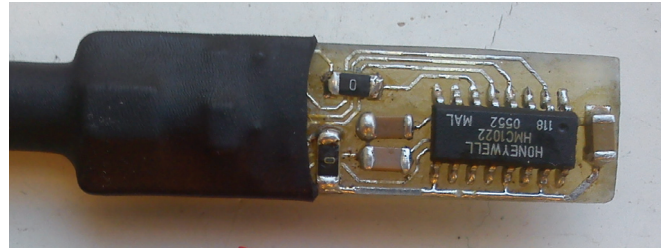

Fig. 9. Magnetic field probe (HMC1022)

During the experiment it was observed that inductor of LED's driver induces strong permanent magnetic field proportional to LED's current and weak alternating magnetic field.

While testing the constructions from other manufacturers it was noticed alternating magnetic field component with less than 2 % intensity from permanent magnetic field strength. This allows simplifying the experiment and enables using 0.1 Hz frequency of stimulation and permanent field measurement.

The influence of induced magnetic field components was estimated by coefficient K

$$K = \sqrt{(B_x - B_{x0})^2 + (B_y - B_{y0})^2 + (B_z - B_{z0})^2} \quad (2)$$

where B_x , B_y , B_z – measured instantaneous values of magnetic induction; B_{x0} , B_{y0} , B_{z0} – values of magnetic induction when PCB power is switched off. During the experiment the current LED's driver was 150 mA, RS485 0.3 A, power supply current 0.3 A.

It was determined that minimal gap between the inductor without a shield and the sensor should be more than 60–70 mm (Fig. 11).

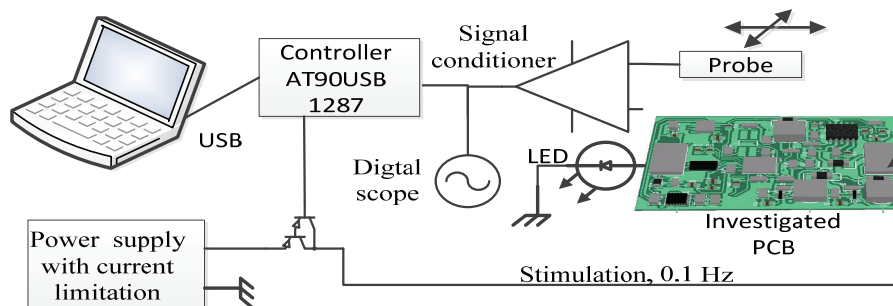

Fig. 10. Schematics of sensor sensitivity measurement setup

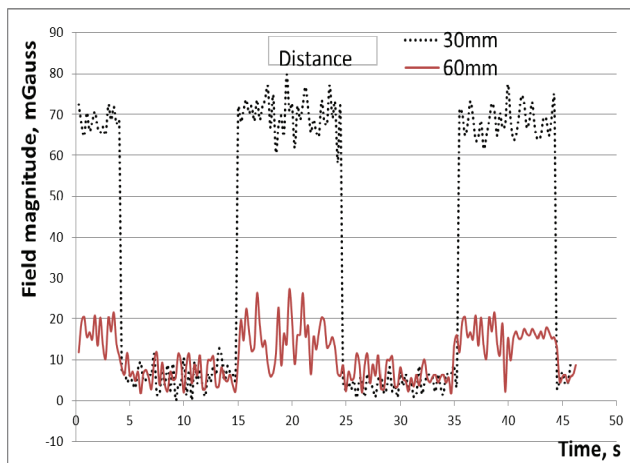

Fig. 11. LED driver inductor without shielding magnetic field magnitude, distance 30 mm and 60 mm from sensor

Power lines (width of the wire 1 mm, gap between the wires 2.25 mm) were stimulated by 0.1 Hz, 300 mA impulses. The obtained results show that the current in power wires (as well as in the case of modeling using Comsol) has a significant influence (Fig. 12).

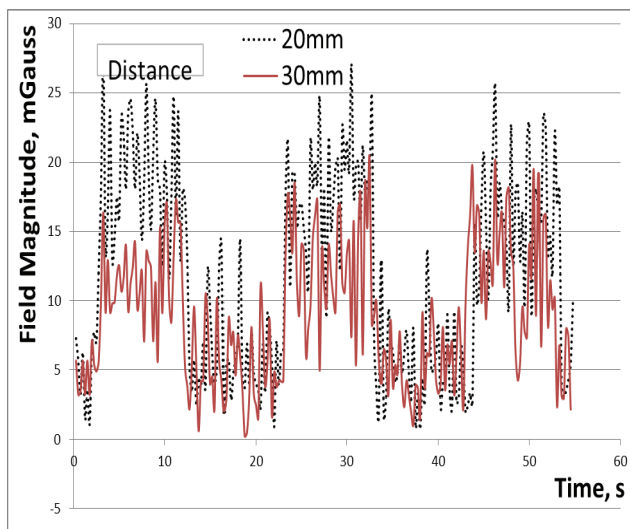

Fig. 12. Two parallel wire for LED supply magnetic field magnitude, current 0.3 A, distance 20 mm and 30 mm from sensor

Minimal gap between the sensor and wires should be no less than 30–40 mm. It has to be noticed that the current was only 300 mA, while a current in a sensors' network can reach 3–10 A. Hence, the magnetic field inducted will be 10 times stronger.

Conclusions

It was found that LED's and power inductors should be placed further than 50–70 mm from AMR sensor.

The gap between power and RS485 lines depend on current, but it has to be more than 50–70 mm.

The twisting of PCB traces reduces magnetic field only in a close zone. In a further distance this twisting has almost no influence.

When implementing sensor to PCB, twisted lines for power supply and RS485 interface should be used.

Experimental measurement results are nearly related with modeling results.

References

1. Honeywell. **Applications of Magnetic Position Sensors**. Online: <http://www51.honeywell.com/aero/common/documents/Applications-of-Magnetic-Position-Sensors.pdf>.
2. Honeywell. **AN212 Handling Sensor Bridge Offset**. http://www51.honeywell.com/aero/common/documents/myaerospacecatalog-documents/Defense_Brochures-documents/Magnetic_Literature_Application_notes-documents/AN212_Handling_of_Sensor_Bridge_Offset.pdf.
3. Xisheng L., Jia Y., Xiongying S., Ruiqing K. Electric Current measurement using AMR Sensor Array // Proceedings of the 2009 IEEE International Conference on Mechatronics and Automation. – Changchun, China, 2009.
4. Taghvaeayan S., Rajamani R. The Development of AMR Sensors for Vehicle Position Estimation // American Control Conference on O'Farrell Street. – San Francisco, CA, USA, 2011.
5. Markevicius V., Navikas D. Adaptive Thermo-Compensation of Magneto-Resistive Sensor // Electronics and Electrical Engineering. – Kaunas: Technologija, 2011. – No. 8(114). – P. 43–46.
5. Petersen T. F., Pryds N., Smith A. Using a Linux Cluster for Parallel Simulations of an Active Magnetic Regenerator Refrigerator // Excerpt from the Proceedings of the 2006 Nordic COMSOL Conference, 2006. – P. 1–6.

Received 2011 06 15
Accepted after revision 2011 09 09

V. Markevicius, D. Navikas, M. Cepenai. **Magnetic Field Simulation in Embedded System with Magneto-Resistive Sensor // Electronics and Electrical Engineering. – Kaunas: Technologija, 2011. – No. 9(115). – P. 105–108.**

While designing embedded systems with magnetic resistance sensors, the influence of components inducted magnetic field should be estimated. The modeling of inductor, power and RS485 lines was performed using COMSOL. The modeling results allow set minimal distances between investigated components and AMR sensor. The modeling results were experimentally tested using HMC1022 sensor and data acquisition device. Ill. 12, bibl. 5, tabl. 2 (in English; abstracts in English and Lithuanian).

V. Markevičius, D. Navikas, M. Čepėnas. **Įterptinių sistemų su magnetorezistoriniais jutikliais modeliavimas // Elektronika ir elektrotechnika. – Kaunas: Technologija, 2011. – Nr. 8(114). – P. 105–108.**

Projektuojant įterptines sistemas, kuriose naudojami magnetorezistoriniai jutikliai, būtina įvertinti įvairių komponentų kuriamo magnetinio lauko įtaką jutikliui. Naudojantis programa COMSOL atliktas induktoriaus, maitinimo bei RS485 linijų modeliavimas. Modeliavimo rezultatai leidžia nustatyti minimalius atstumus tarp tiriamųjų elementų ir magnetorezistorinio jutiklio. Modeliavimo rezultatai patikrinti eksperimentiškai, matavimams naudojant jutiklį HMC1022 ir duomenų surinkimo bei registravimo įrenginį. Il. 12, bibl. 5, lent. 2 (anglų kalba; santraukos anglų ir lietuvių k.).