

A Development of a Capacitive Voltage Divider for High Voltage Measurement as Part of a Combined Current and Voltage Sensor

Roman Hrbac¹, Vaclav Kolar^{1,*}, Mikolaj Bartlomiejczyk², Tomas Mlcak¹, Petr Orsag¹,
Jakub Vanc¹

¹Faculty of Electrical Engineering and Computer Science, VSB-Technical University of Ostrava,
17. listopadu 15, 708 00 Ostrava, Czech Republic

²Faculty of Electrical and Control Engineering, Gdansk University of Technology,
ul. G. Narutowicza 11/12, 80-233 Gdansk, Poland
vaclav.kolar@vsb.cz

Abstract—This article deals with the development of capacitive voltage divider for high voltage measurements and presents a method of analysis and optimization of its parameters. This divider is a part of a combined voltage and current sensor for measurements in high voltage power networks. The sensor allows continuous monitoring of the network distribution status and performs a quick diagnosis and location of possible network failures. Deployment of these devices will support semi-autonomous control of power networks and it can be considered as a step from traditional power grids toward smart grids. This is a worldwide trend connected with increasing number of renewable energy sources and plug-in electric vehicles as described in. In this way, it contributes to the reliability of the distribution network. Together with automated control techniques and fault location methods, it enables its self-healing capability. The following characteristics required for the sensor include: current measurement error up to 2 %, voltage measurement error up to 0.5 %, and power measurement error up to 5 %. At the same time, it is necessary that the sensor is cost-effective - relatively cheap. There were selected capacitors made in series production for the capacitive divider designing. The capacitive voltage divider was tested in terms of time and temperature stability; the results are described in the paper. Then, the method of mathematical correction of a temperature dependence of the capacitive voltage divider was suggested and tested.

Index Terms—Voltage measurement; Capacitive divider; Temperature dependence; Error compensation.

I. INTRODUCTION

Voltage instrument transformers based on inductive principle are most often used to measure high AC voltage in distribution networks. Their advantages include high accuracy (accuracy class usually from 0.1 to 3), relatively high output power from 1 VA to 100 VA [1], as well as temperature and time stability. The significant advantage is a galvanic isolation of input and output with high isolation

strength. For example, for voltage instrument transformers up to 24 kV, it is 50 kV Root Mean Square (RMS) for 60 seconds and voltage pulse 125 kV 1.2 μ s/50 μ s [2]. However, their disadvantages are high cost and weight [3] and increased measurement error for non-sinusoidal waveforms or transients [4].

In recent years, optoelectric voltage sensors using Pockels effect (using optically anisotropic materials) have also begun to be used for high voltage measurements. They are based on fiber Bragg gratings and piezoelectric crystals. They exhibit immunity to electromagnetic interference, galvanic isolation, and wide bandwidth. Their development has already reached the commercial stage, but they are still not very commonly used. In addition to many good properties, they also have some seriously bad ones, such as a temperature dependence [5]. Furthermore, high voltage measurement technologies based on liquid crystal sensor were developed [6], but they are still in stage of laboratory development.

Another widespread principle of voltage measurement is a capacitive voltage divider. Unlike a resistive divider (which is used mainly at low voltage and it can also be used for DC voltage), there is almost no power loss. However, unlike the measuring transformer, it does not provide galvanic isolation of the input and output voltage. The internal impedance of the capacitive divider is very high, compared to the measuring transformer, so almost no current can be taken from it. For this reason, its load impedance must be very high. However, its big advantage over the measuring transformer is its lower cost and weight. For example, a 25 kV measuring transformer (unnamed manufacturer) weighs 29 kg and costs approximately 1000 Euro, a 25 kV capacitive sensor (capacitive divider) from the same manufacturer is about 5 times lighter and 2.5 times cheaper. For these reasons, capacitive dividers are often used for high voltage measurement [7].

The intention of the team of authors was to develop a cost-effective 22 kV capacitive voltage divider that would be part of a combined voltage and current sensor for measurement at a 22 kV power line.

II. A DESIGNED CAPACITIVE DIVIDER

For good stability and linearity of capacitive divider, it would be favourable to use the same capacitors for both high voltage and low voltage parts of the divider. This is suggested in [8] for a 150 kV capacitive voltage divider. However, in that case, it requires 308 capacitors of 3.3 nF in series for high voltage part and 3 such capacitors in parallel for low voltage part, what is very unpractical. For our purposes, we can choose another combination of different capacitors, and we evaluated several combinations. Nevertheless, this solution was still unpractical and expensive.

According to [9], it is good to use compressed gas, high voltage capacitors with voltage ratings in the high voltage part of capacitive divider. They have extremely good stability and linearity for both magnitude and phase. Unfortunately, the capacitors are expensive and fragile. They are suitable for accurate laboratory measurement, but not for our application, which should be robust and cheap.

Therefore, we decided to use commercially manufactured high voltage capacitors to ensure the cost-effectiveness of the product, which is being developed.

High voltage ceramic capacitors MZS55PC50KV202K with capacitance of 2 nF and nominal voltage of 50 kV were chosen for high voltage parts. The capacitors contain a ceramic dielectric, which the manufacturer refers to as "PULSE-CERAMIC firing dielectric ceramic material". It is supposed to be their own material. The capacitors have a non-repetitive peak voltage overload of 100 kV [10]. These capacitors are in series of two in a voltage divider achieving theoretically a pulse voltage endurance of up to 200 kV, which complies with the norm [2] requiring value of 125 kV. The resulting capacity is then 1 nF (see Fig. 1). The ceramic capacitors 474J5GACTU with dielectric C0G serve as low voltage capacitors in the divider. This type of capacitor is the most stable from the commercially available ceramic capacitors and therefore most suitable for measuring purposes. In [9], these capacitors are used for measurement purposes also.

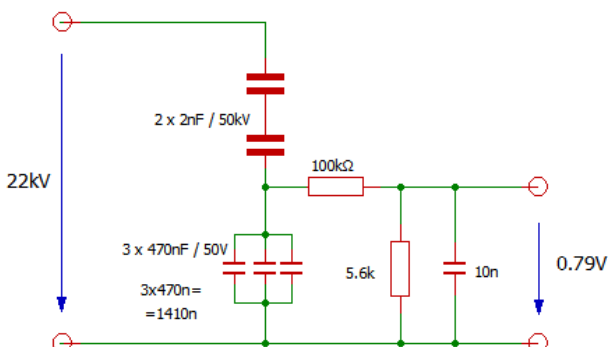

Fig. 1. Designed capacitive divider with a following resistive voltage divider and a low-pass filter.

The circuit in Fig. 1 has a dividing ratio of 27690:1 and a phase shift of 0.44° for a 50 Hz frequency. The resistors connected in the circuit together with the 10 nF capacitor form a low-pass filter with a cut-off frequency of 3114 Hz. The signal in the designed sensor will be further digitally processed at a sample rate of 16 kS/s, which complies with

the cut-off frequency of the filter. The phase shift of 0.44° can be easily corrected in the digital processing.

Due to the deviation of the values of the used components, the circuit can show deviation in the dividing ratio and the phase. In case of an individual calibration of every produced sensor, these deviations can be eliminated by calibration constants in the microprocessor in the sensor.

However, an important fact that will affect the accuracy of the sensor in real operation is the time and temperature stability, which has to be researched during the development.

III. ACCURACY REQUIREMENTS OF THE DESIGNED SENSOR

When developing a combined voltage and current sensor, there was set a target to have a voltage measurement error up to 0.5 % and a current measurement error up to 2 % at rated values (this is influenced by the used current sensor, which we don't deal with in this paper). These values were stated according to [11] and in accordance with experiences of our industrial partner (producer of power network diagnostic devices) also. The permissible error of active power measurement of the first harmonic component was set at 5 % (indicative power measurement). From these parameters, the requirement of accuracy of the phase shift measurement can be determined as follows.

For the active power of first harmonic, there is a generally known relation

$$P = R \times I \times \cos(\phi). \quad (1)$$

The power measurement error can be expressed as a total differential

$$\begin{aligned} \Delta P &= \partial P / \partial U \times \Delta U + \partial P / \partial I \times \Delta I + \partial P / \partial \phi \times \Delta \phi = \\ &= \Delta U \times I \times \cos(\phi) + \Delta I \times U \times \cos(\phi) + \\ &+ \Delta \phi \times U \times I \times \sin(\phi). \end{aligned} \quad (2)$$

The percentage error is then

$$\Delta P_{\%} = \Delta P / P \times 100 = \Delta U_{\%} + \Delta I_{\%} + \Delta \phi_{\%} \times \tan(\phi). \quad (3)$$

Further the permissible phase shift measurement error is

$$\Delta \phi = (\Delta P_{\%} - \Delta U_{\%} - \Delta I_{\%}) / \tan(\phi) \times \phi / 100. \quad (4)$$

Assuming a power factor in the network of 0.8 up to 1, this corresponds to a phase shift of 0.643 radians up to 0 radians.

For the angle $\phi = 0$, the expression $\phi / \tan(\phi)$ cannot be quantified numerically, but its limit is 1.

Then, the permissible error value of the phase shift measurement is from 0.021 radian up to 0.025 radian. In order to ensure proper functioning, we must count on the smaller of these values. We will further consider that half of the angle measurement error will get on the voltage sensor and half - on the current sensor. Thus, the permissible error value of the phase shift voltage measurement in degrees will be

$$\Delta \phi = (0.021 \times 180) / 2\pi = 0.6^\circ. \quad (5)$$

IV. AN EXPERIMENTAL WORKPLACE FOR THE CAPACITIVE DIVIDER TESTING

For proper operation of the combined voltage and current sensor and its main purpose (failure location), it is very important to keep maximum voltage error below the stated limit [11] in all operation conditions during sensor lifetime. Because properties of different capacitors are influenced by temperature changes and aging [12]–[14], it was necessary to verify the behaviour of developed capacitive divider.

To test the properties of the capacitive divider, an experimental workplace was assembled (its connection is visible in Fig. 2). In this circuit, two high voltage capacitors are not connected in series, there is only one, and the supply voltage is reduced to the half value (i.e., 11 kV). This connection is advantageous because of the smaller isolation distances.

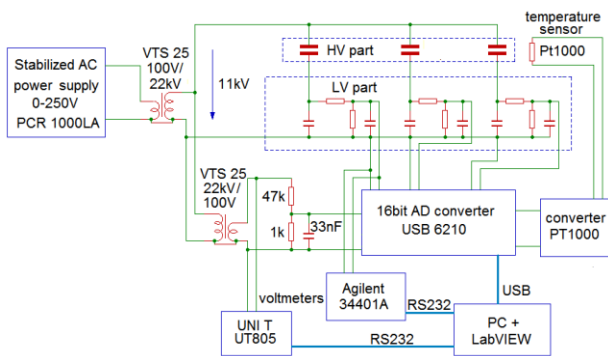

Fig. 2. Experimental circuit for verification of properties of the capacitive divider.

Most of the measured values are measured by the analog-to-digital converter USB6210 with a sample rate of 20 kS/s. In the first variant of testing, a mains-powered regulating autotransformer was used instead of AC Power Supply PCR 1000LA. However, it was found that voltage fluctuations in the mains (although only about 1 %) had an undesirable effect on the measurement results. Therefore, later was used a stabilized 1000LA PCR source.

Three capacitive voltage dividers are measured at the same time in order to measure more statistical samples.

When measuring, it is the most important to verify changes in the voltage divider depending on the temperature and time. Absolute accuracy is not the most important thing at the moment; what is important that there are changes in measured values. During the measurement, there may be small changes in values. It is not clear in advance, if the changes come from the high voltage capacitor, the low-voltage capacitor or from the USB 6210 converter itself. In order to diagnose, in which part of the circuit these changes occur, some voltages are also measured independently with Agilent 34401A and UNI T UT805 digital voltmeters.

Both digital voltmeters measure RMS value of the voltage. The values measured by the USB 6210 converter are processed in software created in LabVIEW. The software evaluated the harmonic component of 50 Hz, both its RMS value and the phase shift.

The testing circuit is designed, so that the high voltage and low voltage parts are separate units that can be placed

separately in the constant climate chamber. The circuit diagram of the testing circuit is shown in Fig. 2 and the three high voltage capacitors ready for testing are shown in Fig. 3.



Fig. 3. Ready-to-test high voltage capacitors.

V. MEASUREMENTS ON THE CAPACITIVE DIVIDER

In total, 6 high voltage capacitors were tested; three capacitive dividers were always tested simultaneously.

At the beginning of each measurement, both the voltage and phase shift values were calibrated, so that at this point the voltage and phase shift deviations were zero (calibration constants were set in the computer program).

During the measurement, it was necessary to verify that deviations that occur during the measurement are not caused by the error of the measuring apparatus (based on the USB6210 converter), but that they come from changes in the researched voltage divider. This was done so that some quantities were measured by the USB6210 converter, as well as by the digital voltmeters. Figure 4 shows a comparison of the two measurements, showing that the values measured by the USB6210 converter and by the digital voltmeters are substantially the same. Therefore, the used measuring apparatus did not bring a noticeable error to the measurement.

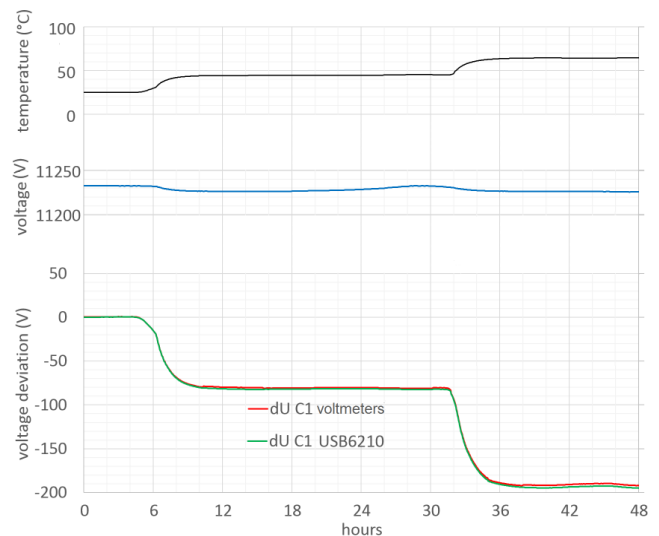

Fig. 4. The comparison of measurement by the USB6210 and by the digital voltmeters.

A three-day long stability test of all six capacitors was done at a constant temperature of 25 °C. The results are shown in Fig. 5.

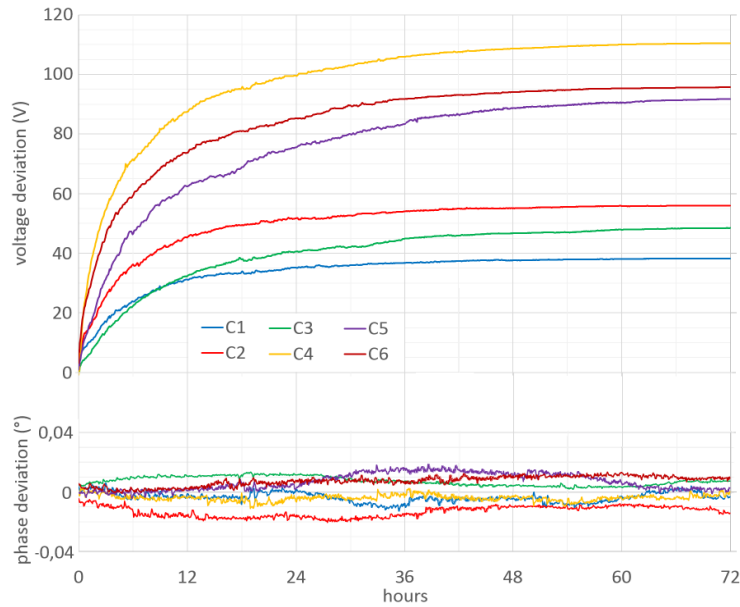

Fig. 5. Long-term stability test of high voltage capacitors.

As you can see from Fig. 5, in the first 48 hours after switching on the voltage of the capacitor divider is being stabilized. Output voltage is completely stabilized after about 72 hours (three days). The highest recorded deviation was 110 V for the C4 capacitor, which represents 1 % of the measured voltage. This is a significant value, so in the further measurements, it is necessary to let the capacitor divider stabilize for two or three days on the rated voltage. This rule must also be kept in the further calibration of the capacitive divider during its production. This process is not caused by heating the capacitor and its temperature dependence (as it seems at first sight). From the following temperature measurements, it is evident that the temperature dependence of capacitors is reversed, with heating a negative voltage deviation. The whole process is probably caused by polarization effects in the dielectric of the high voltage capacitor. Relaxation polarization or interlayer polarization may be an explanation [15].

Voltage divider phase shift error was very low during the whole test, within $\pm 0.03^\circ$, i.e., below the permissible phase shift error. There is no need to solve it.

After 72 hours of stabilization of the capacitive divider, the temperature dependence of the capacitors was tested. The temperature of the low-voltage capacitor of the capacitive divider (and other components) remained constant approximately at about 25°C . The high voltage capacitors were placed into the constant climate chamber and the temperature was gradually changed between -20°C and $+65^\circ\text{C}$. At each of these temperatures, they were kept for 20–25 hours. The temperature range was chosen with regard to extreme temperature changes in Central Europe [16], the strongest frost of about -20°C and the highest summer temperature in a direct sunlight of about $+50^\circ\text{C}$. We assumed that the interior of the sensor will be approximately 5°C warmer due to losses in components, and to be sure, we chose the test temperature range from 5°C to 10°C higher.

The measurement results are shown in Fig. 6 and Fig. 7.

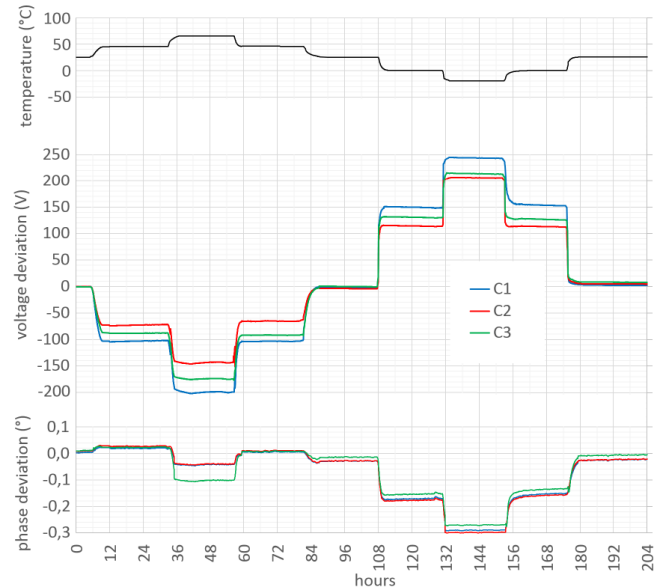

Fig. 6. The results of the temperature test of high voltage capacitors 1, 2, and 3.

Figure 6 and Figure 7 show that the voltage deviation of some capacitors reaches up to 250 V, which represents 2.3 % of the measured voltage. This error is much higher than the required error of 0.5 %, and therefore the temperature dependence of the capacitors has to be compensated. This is described later in Section V. The phase shift deviation is a maximum of 0.3° , which complies with the stated requirement of $\pm 0.6^\circ$.

Furthermore, the temperature dependence of the low-voltage part of the capacitive divider was measured. The high voltage capacitors were placed at a constant temperature of 25°C and the low-voltage part (see Fig. 2) was placed in a constant climate chamber. During the preliminary measurement, it was found that the thermal stability of the low-voltage part of the divider, especially of capacitors with COG dielectric, is much better than at the

high voltage capacitors (this can be assumed from the manufacturer's catalogue data as well). Therefore, the test for measuring the low-voltage part of the divider could be shorter. The test results are shown in Fig. 8.

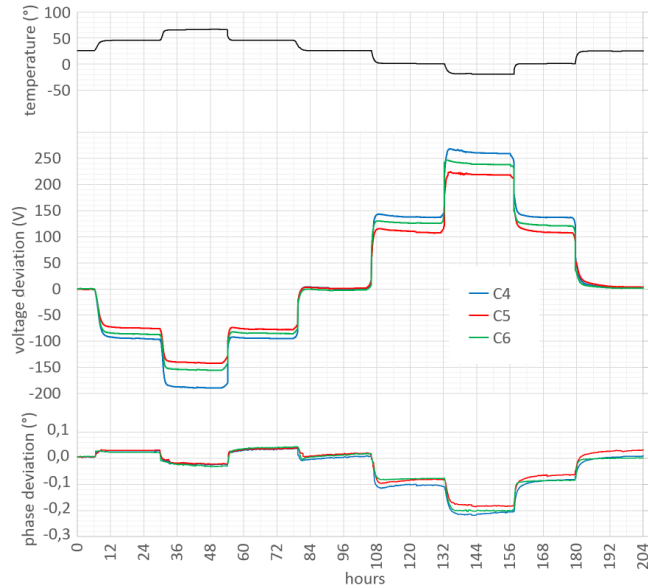

Fig. 7. The results of the temperature test of high voltage capacitors 4, 5, and 6.

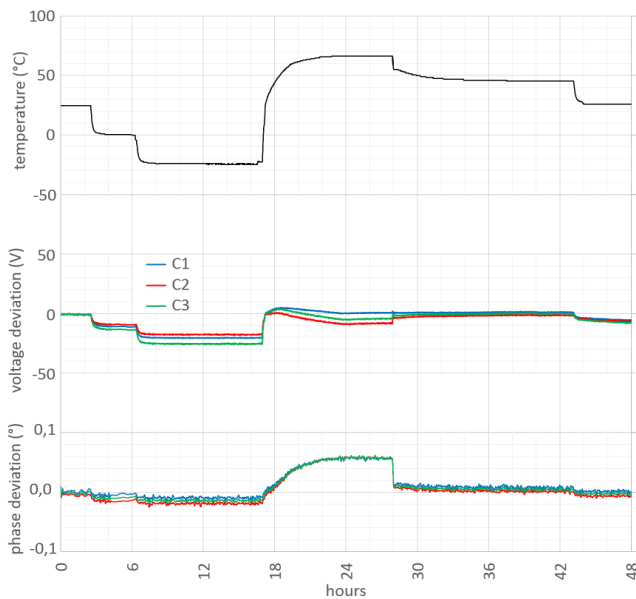

Fig. 8. The results of the temperature test of low-voltage part of the capacitive divider.

Figure 8 shows that the voltage deviation in the entire temperature range does not exceed 30 V, which is 0.3 % of the measured voltage. The phase shift deviation is maximally of 0.06 °, which is below the permissible deflection of 0.6 °. These deviations themselves do not require correction, but since software temperature correction must be done in the sensor anyway, it is appropriate to include this deviation as well.

Table I summarizes the measurement results for all tested capacitors.

The values from Table I are further illustrated in Fig. 9.

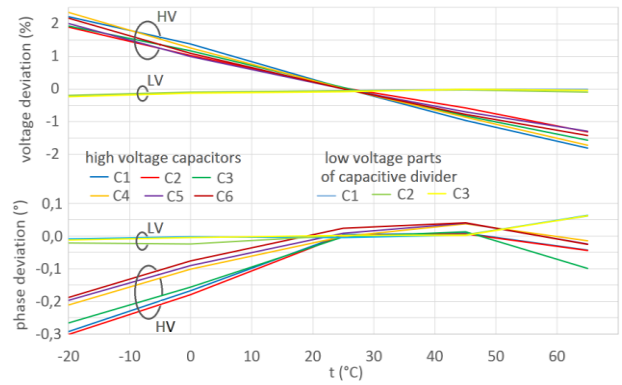

Fig. 9. Summary of the results of thermal test of the capacitive divider.

TABLE I. SUMMARY OF TEMPERATURE TEST RESULTS OF THE CAPACITIVE DIVIDER.

		-20 °C	0 °C	25 °C	45 °C	65 °C
HV capacitors' voltage deviation (%)	C1	2.22	1.38	0.02	-0.96	-1.81
	C2	1.89	1.03	0.04	-0.58	-1.31
	C3	1.94	1.17	0.06	-0.82	-1.57
	C4	2.35	1.26	0.01	-0.86	-1.72
	C5	2.01	0.99	0	-0.7	-1.29
	C6	2.18	1.1	0	-0.78	-1.42
HV capacitors' phase shift (°)	C1	-0.293	-0.167	0.004	0.009	-0.043
	C2	-0.301	-0.18	0.002	0.007	-0.044
	C3	-0.266	-0.157	-0.002	0.013	-0.099
	C4	-0.211	-0.102	-0.001	0.037	-0.015
	C5	-0.197	-0.09	0.009	0.039	-0.024
	C6	-0.188	-0.076	0.024	0.041	-0.026
LV part of the divider voltage deviation (%)	C1	-0.21	-0.1	-0.05	0	0
	C2	-0.19	-0.09	-0.04	-0.03	-0.09
	C3	-0.24	-0.12	-0.08	0	-0.04
LV part of the divider phase shift (°)	C1	-0.009	-0.002	-0.005	0.003	0.064
	C2	-0.021	-0.024	0.002	0.004	0.061
	C3	-0.012	-0.005	0.002	0.002	0.063

VI. A CORRECTION OF TEMPERATURE DEPENDENCE OF THE CAPACITIVE DIVIDER

In order to achieve the accuracy of the combined voltage and current sensor listed in Section III, a temperature correction of the measured voltage is required. This will be a mathematical correction being performed by the microprocessor in the sensor. It is desirable that the correction algorithm is as simple as possible for reasons of simplicity and reliability.

It is assumed that in future production each sensor is going to be individually tested in a constant climate chamber and correction constants are going to be written into each of them. However, due to the time-consuming nature of such process, it is going to be measured only at two temperatures. First, the sensor is going to be stabilized for 72 hours at 25 °C, then the values are going to be measured at this temperature, then the sensor is going to be cooled to 0 °C, and after 24 hours, the values are going to be measured at this temperature. The entire calibration is going to take approximately 96 hours, which means 4 days.

It was decided not to compensate the temperature dependence at the phase shift. The phase shift is going to be compensated by a constant value at the temperature of 0 °C.

Then, the phase shift deviation caused by the temperature changes should not exceed 0.2° over the expected temperature range.

Relation

$$\phi_{\text{corrected}} = \phi_{\text{measured}} \times K_{\phi}. \quad (6)$$

A linear function was selected to compensate the voltage measurements

$$U_{\text{corrected}} = U_{\text{measured}} \times (K_{V1} \times t + K_{V2}), \quad (7)$$

where t is the temperature.

The constants K_{ϕ} , K_{V1} , and K_{V2} are going to be determined from measurements at 25°C and 0°C as follows:

$$K_{\phi} = \phi_{\text{transformer } 0^\circ\text{C}} - \phi_{\text{capacitive divider } 0^\circ\text{C}}, \quad (8)$$

$$K_{V2} = V_{\text{transformer } 0^\circ\text{C}} - V_{\text{capacitive divider } 0^\circ\text{C}}, \quad (9)$$

$$K_{V1} = (V_{\text{transformer } 25^\circ\text{C}} / V_{\text{capacitive divider } 25^\circ\text{C}} - K_{V2}) / 25. \quad (10)$$

Variables with the ‘‘transformer’’ index are measured using a measuring transformer that we consider accurate. Variables with the ‘‘capacitive divider’’ index are measured by the capacitive divider, which we want to adjust.

VII. THERMAL TESTING OF A COMPLETE CAPACITIVE DIVIDER

For the final temperature stability test, three capacitive dividers were assembled, into which high voltage capacitors showing the highest temperature dependence were selected to check the most unfavourable case. These were C1, C4, and C6. The three dividers were subjected to a calibration measurement for 4-day period. The whole capacitive divider (HV and LV part) was tested in the constant climate chamber. The measurement results are shown in Fig. 10.

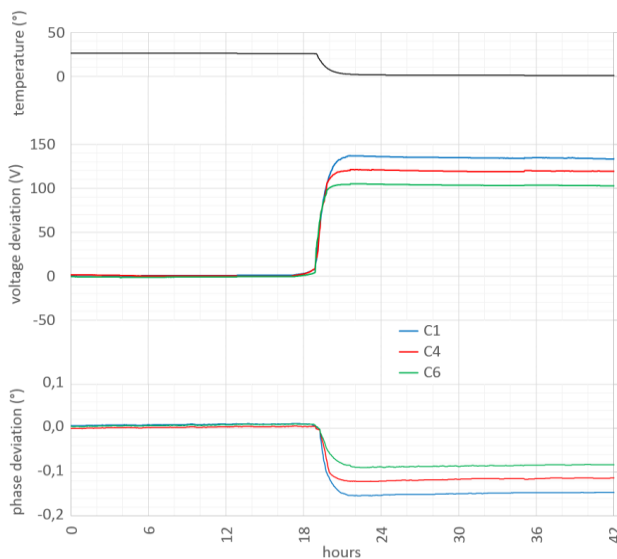

Fig. 10. Results of calibration measurement of capacitive voltage dividers with high voltage capacitors C1, C4, and C6.

Based on this measurement, the calibration constants K_{ϕ} , K_{V1} , and K_{V2} were determined according to (8)–(10). The

results are shown in Table II.

TABLE II. CALIBRATION MEASUREMENT RESULTS.

	V_{C1} (V)	V_{C4} (V)	V_{C6} (V)	ϕ_{C1} ($^\circ$)	ϕ_{C4} ($^\circ$)	ϕ_{C6} ($^\circ$)
0°C	134.5	119.5	103.4	-0.148	-0.116	-0.085
25°C	0.7	0.4	-1.1	0.008	0.002	0.006
	C1	C4	C6	-	-	-
K_{ϕ}	0.148	0.116	0.085	-	-	-
K_{V1}	0.000484	0.000430	0.000371	-	-	-
K_{V2}	0.9879	0.9892	0.9910	-	-	-

After that, the capacitive dividers were subjected to measurements in the constant climate chamber, at which the temperature varied stepwise between -20°C and $+65^\circ\text{C}$. The measurement results were mathematically corrected according to (5) and (6) and the constants in Table II. The measurement results are shown in Fig. 11.

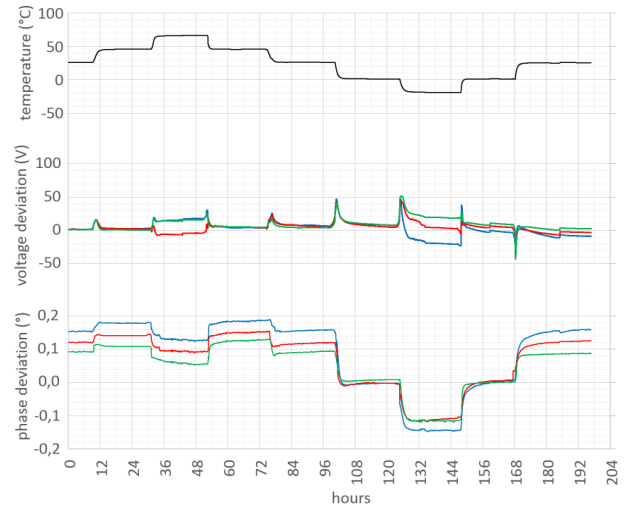

Fig. 11. Measurement results of capacitive dividers with compensation.

From the measurement results in Fig. 11, it is obvious that maximal voltage deviation is 50 V, which represents 0.45 % of the measured value (11 kV). The phase shift error is a maximum of 0.2° . Both values comply with the accuracy requirements. Reference [11] states values 0.7 % and $0.7 \text{ grad} = 0.63^\circ$ for steady states, what is our case. However we have set even stricter limits (0.5 % and 0.6°) in Section II, which are still met. Parameters of our sensor are sufficient for both localization of network failures and indicative power measurement.

Furthermore, it can be seen from the record that during the temperature change the voltage deviation (peak) is temporarily increased. The size of the largest peaks is about 0.45 %, which is less than the set value of 0.5 %, but is close to this value. The peak duration is about 3 hours and that corresponds to the time of temperature stabilization when changing from one value to another. This error is probably caused by the gradual penetration of an ambient temperature into the high voltage capacitor and the different thermal time constant of the temperature sensor and the high voltage capacitor.

The reduction of this temporary error is going to be a subject of further research. The simplest solution is to place the temperature sensor in a close physical contact with the

HV capacitor so that the temperature of the sensor accurately follows the temperature of the capacitor during heating and cooling. However, keeping the isolation distances is a limiting factor. A more complicated option may be to create a mathematical algorithm of the deviation compensation that includes the thermal inertia of the capacitor (thermal time constant). Thermal modelling of capacitive voltage divider is solved in [17], where thermal time constant is taken into account. It may be the way to solve this problem. However, whether the creation of such algorithm is realistic and whether this algorithm would be reliable, it must be tested first.

As far as the phase shift error is concerned, it does not even reach half of the permissible value over the entire temperature range of the measurement, so it is not necessary to consider any reduction.

VIII. CONCLUSIONS

In the frame of the development of a combined current and voltage sensor intended for measurement in HV networks, there was developed a capacitive voltage divider as a substitution of classical inductive voltage instrument transformer. This divider uses MZS55PC50KV202K high voltage capacitors, which are favourable because of their cost. Requirements for accuracy of voltage, current, power, and phase shift measurements were determined for the sensor in Section II according to [11]. A total of 6 capacitive dividers were subjected to laboratory testing. During the laboratory testing of the capacitive divider, it was found that after connecting the capacitive divider to voltage it stabilizes for about 48 hours. Immediately after connection, the deviation of the measured voltage is highest and for some capacitors, it was about 1 %, which exceeds the specified permissible value of 0.5 %, but after about 6 hours, it already drops below the permissible value. In addition, capacitive dividers were tested in the constant climate chamber. There was found temperature dependence caused mainly by temperature dependence of high voltage capacitors. Measurement error caused by temperature changes exceeded the permitted range. Further, to compensate this temperature dependence, a mathematical algorithm was developed and tested. It was verified, that after correction by this algorithm, the accuracy of measurement complied with the specified requirements.

Accuracy after mathematical correction is also within limits of most common classes of inductive voltage instrument transformer [3].

In the future, it is possible to improve the mathematical algorithm so that it includes the thermal time constant of the HV capacitor, which must be researched further.

CONFLICTS OF INTEREST

The authors declare that they have no conflicts of interest.

REFERENCES

- [1] *Instrument transformers - Part 3: Additional requirements for inductive voltage transformers*, European standard EN 61869-3, 2012.
- [2] *Insulation co-ordination - Part 1: Definitions, principles and rules*, European standard EN 60071-1 ed. 2, 2006.
- [3] S. Saha, S. K. Bera, H. S. Mandal, K. B. Pradip, and Ch. Satish, "Study of an accurate electronic power measurement technique using modified current transformer and potential transformer", *Transactions of the institute of measurement and control*, vol. 41, pp. 3666–3678, 2019. DOI: 10.1177/0142331219835010.
- [4] M. Kaczmarek and R. Nowicz, "Application of instrument transformers in power quality assessment", in *Proc. of 2010 Modern Electric Power Systems*, Wroclaw, 2010, pp. 1–5.
- [5] M. N. Goncalves, N. Marcelli, and M. M. Werneck, "A temperature-independent optical voltage transformer based on FBG-PZT for 13.8 kV distribution lines", *Measurement*, vol. 147, p. 106891, 2019. DOI: 10.1016/j.measurement.2019.106891.
- [6] J. Firtha, Z. Brodzelia, M. Ciobotaru, T. Phunga, F. Ladouceura, and L. Silvestri, "Accurate optical measurement of high voltage waveform using novel optical liquid crystal based sensor", *Sensors and Actuators A: Physical*, vol. 268, pp. 164–172, 2019. DOI: 10.1016/j.sna.2017.11.015.
- [7] F. Rahmatian, "High-voltage current and voltage sensors for a smarter transmission grid and their use in live-line testing and calibration", in *Proc. of 2011 IEEE power and energy society general meeting*, Minneapolis, 2011, pp. 1–3. DOI: 10.1109/PES.2011.6039093.
- [8] M. Teachawong and C. Trakulkan, "Design and invention a 150 kV capacitive high voltage divider set", in *Proc. of 4th Joint International Conference on Information and Communication Technology, Electronic and Electrical Engineering (JICTEE)*, Chiang Rai, 2014, pp. 1–5. DOI: 10.1109/JICTEE.2014.6804114.
- [9] E. Mohns, J. Chunyang, H. Badura, and P. Raether, "An active low-voltage capacitor for capacitive HV dividers", in *Proc. of 2018 Conference on Precision Electromagnetic Measurements (CPEM 2018)*, Paris, 2018, pp. 1–2. DOI: 10.1109/CPEM.2018.8501238.
- [10] High voltage pulse ceramic capacitor MZS-PC series, Amazing technology (HK) CO., LIMITED, Guangdong, China, 2018.
- [11] D. Carta, P. A. Pegoraro, and S. Sulis, "Impact of measurement accuracy on fault detection obtained with compressive sensing", in *Proc. of 2018 IEEE 9th International Workshop on Applied Measurements for Power Systems (AMPS)*, Bologna, 2018, pp. 1–5. DOI: 10.1109/AMPS.2018.8494846.
- [12] B. Liu, W. Chen, W. Shang, Q. Liu, L. Chu, and S. Chen, "The influence of the partial discharge on the electrical aging property of high voltage ceramic capacitor", in *Proc. of 1998 Asian International Conference on Dielectrics and Electrical Insulation (AICDEI)/30th International Symposium on Electrical Insulating Materials (ISEIM 98)*, Toyohashi, Japan, 1998, pp. 763–765. DOI: 10.1109/ISEIM.1998.741858.
- [13] J. Vodrazka, M. Horak, and K. Dusek, "Aging analysis of metalized film capacitors", in *Proc. of the 16th International Conference on Mechatronics - Mechatronika 2014*, Brno, 2014, pp. 648–651. DOI: 10.1109/MECHATRONIKA.2014.7018336.
- [14] D. Andriukaitis, R. Anilionis, T. Kersys, "LOCOS CMOS process simulation", in *Proc. of 28th International Conference on Information Technology Interfaces (ITI 2006)*, Cavtat/Dubrovnik, Croatia, 2006, pp. 489–494. DOI: 10.1109/ITI.2006.1708530.
- [15] B. C. Steele, *Electronic Ceramics*. London, Elsevier, 1991.
- [16] E. Kjellström, F. Boberg, M. Castro, J. H. Christensen, G. Nikulin, and E. Sánchez, "Daily and monthly temperature and precipitation statistics as performance indicators for regional climate models", *Climate Research*, vol. 44, no. 2–3, pp. 135–150, 2010. DOI: 10.3354/cr00932.
- [17] R. G. Silva, J. P. Brit, J. C. Lira, and J. R. Henri, "Thermal modeling of a capacitor voltage transformer using CFD techniques", *IEEE Latin America Transactions*, vol. 16, no. 8, pp. 2234–2239, 2018. DOI: 10.1109/TLA.2018.8528240.



This article is an open access article distributed under the terms and conditions of the Creative Commons Attribution 4.0 (CC BY 4.0) license (<http://creativecommons.org/licenses/by/4.0/>).