

Analysis of Balanced Three-Phase Induction Motor Performance under Unbalanced Supply using Simulation and Experimental Results

I. Temiz, C. Akuner

Marmara University Technical Education Faculty Electrical Education Department, Goztepee, Istanbul, e-mails: itemiz@marmara.edu.tr, akuner@marmara.edu.tr

H. Calik

Istanbul University Vocational School of Technical Sciences Electrical Program, Avcilar, Istanbul, e-mail: hcalik@istanbul.edu.tr

Introduction

Unbalanced voltage is one of the most frequent disturbances in electrical systems. An induction motor supplied by unbalanced three-phase power system has been investigated to obtain its quantities by resolving into the balanced three-phase components. This is called as symmetrical components method. The circuit quantities of three-phase squirrel cage induction motors fed from unbalanced three-phase system cannot be determined by classical methods, whereas the symmetrical components method should be used. This method introduced by Fortescue is widely utilized for rotating electrical machines. In this method, an unbalanced supply can be defined as combination of zero, forward and reverse sequence components similar to that of a balanced system [1–5].

In this work, A squirrel cage induction motor with short-circuited rotor and the plate values of $P = 1.5$ kW, 380 V, 3.9 A, Y , $n = 1470$ min⁻¹, $f = 50$ Hz, $\cos\phi = 0.8$ is used. This machine has been supplied by balanced and unbalanced power systems respectively for both experimental and modeling methods. Their voltage, current and power parameters are subsequently measured with their harmonic values. The comparisons have been also made for both analysis techniques [1–6].

Symmetrical components of balanced alternating current machines

If the voltages applied to the motor stator windings are unbalanced, the motor characteristics may vary considerably. The three-phase unbalanced voltages (V_1 , V_2 , V_3) can be resolved into forward (V_d , a^2V_d , aV_d), reverse (V_t , aV_t , a^2V_t) and (V_0 , V_0 , V_0) zero three-phase balanced components with the aid of symmetrical components transformation. [3–6]

In general, symmetrical components transformation can be defined as follows

$$\begin{bmatrix} v_o \\ v_d \\ v_t \end{bmatrix} = \frac{1}{3} \begin{bmatrix} 1 & 1 & 1 \\ 1 & a & a^2 \\ 1 & a^2 & a \end{bmatrix} \begin{bmatrix} V_1 \\ V_2 \\ V_3 \end{bmatrix}. \quad (1)$$

In steady-state sinusoidal operation:

$$\begin{cases} v_1(t) = V_1 \cos(\omega t + \gamma_1), \\ v_2(t) = V_2 \cos(\omega t + \gamma_2), \\ v_3(t) = V_3 \cos(\omega t + \gamma_3). \end{cases} \quad (2)$$

If the equations below are defined as follows

$$\begin{cases} v_1 = [V_0 + V_d + V_t], \\ v_2 = [V_0 + a^2V_d + aV_t], \\ v_3 = [V_0 + aV_d + a^2V_t], \\ v_0 = \frac{1}{3} \cdot [v_1 + v_2 + v_3], \\ v_d = \frac{1}{3} \cdot [v_1 + aV_2 + a^2V_3], \\ v_t = \frac{1}{3} \cdot [v_1 + a^2V_2 + aV_3]. \end{cases} \quad (3)$$

In matrix form

$$\begin{bmatrix} v_0 \\ v_d \\ v_t \end{bmatrix} = \frac{e^{j\omega t}}{2} \begin{bmatrix} V_0 \\ V_d \\ V_t \end{bmatrix} + \frac{e^{-j\omega t}}{2} \begin{bmatrix} V_0^* \\ V_d^* \\ V_t^* \end{bmatrix}. \quad (4)$$

In equations (3), V_0 , V_d and V_t represent zero, forward and reverse components respectively. Matricial Equation (4) gives the relation between symmetrical components phasors and their instantaneous values. An

unbalanced three-phase system can be resolved into balanced forward, reverse and zero sequence components by using the above relations and unbalanced phasors. The forward component induces currents that are balanced and in the same phase sequence of the three-phase supply currents. The reverse component generates currents balanced as well but in the opposite phase sequence due to the voltages in reverse phase sequence in the stator. The phasors of the zero sequence are in equal amplitudes and the same phase for all phase sequences of a three-phase power supply.

The equivalent circuit of an induction motor for unbalanced supplies

Let's consider that the rotor speed in rpm and the slip of a motor operating from unbalanced voltage supply are n , σ respectively. Since the phase sequence of forward component is identical to that of the supply, this component induces a magnetic field which rotates in the same direction of the motor shaft. The per phase equivalent circuit for the rotating field is the normal equivalent circuit of an induction motor where the slip in this circuit is σ . The reverse component produces a magnetic field that rotates in the opposite direction with respect to the rotor, whereas the slip is $2-\sigma$. Generally, the reverse magnetic field should be at minimum amplitude, because it causes a large amount of power loss in the motor. If the amplitude of reverse magnetic field is less than that of 5% of the forward component, such a three-phase power system can be supposed as symmetrical in practice. No rotating field is induced by zero component currents, because they are in the same direction for each phase. Any torque is not therefore produced since the resultant field is zero. However a motor fed from V_1, V_2, V_3 unbalanced voltage supply can be considered to consist of two motors operating individually. The first motor operates from forward component of balanced system at V_{d1}, V_{d2}, V_{d3} voltages with σ slip in normal rotation direction. The second motor operates from reverse component of balanced system at V_{t1}, V_{t2}, V_{t3} voltages with $2-\sigma$ slip in opposite direction. The main and two separate motors are shown in Fig. 1. The per phase equivalent circuit for the forward component is obtained by placing σ as the slip, I_{sd} as the stator current and I'_{rd} as the rotor current in the equivalent circuit of symmetrical components of an induction motor operating at unbalanced supply. Similarly, the equivalent circuit for the reverse component can be derived, where $2-\sigma$, I_{st}, I'_{rt} represent the slip, the stator current and the rotor current respectively as illustrated in Fig. 1, a and Fig. 1, b.

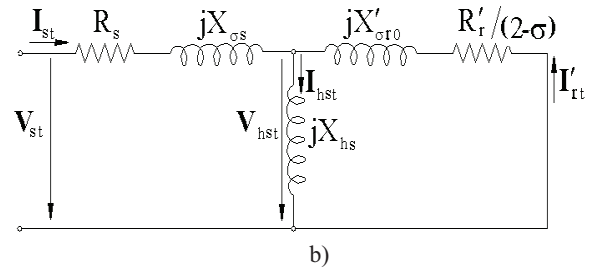
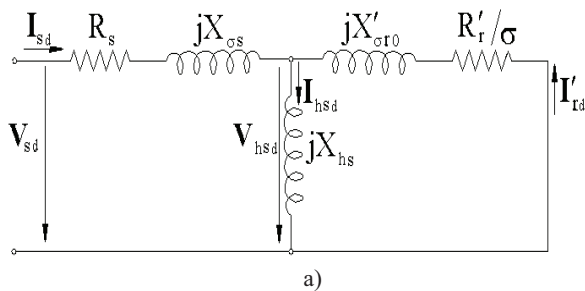

Fig. 1. Equivalent circuit: a – for forward component; b – For reverse component

Obtaining circuit parameters of the induction motor by experimental tests

The stator winding parameters of the motor used in this study obtained by the measurements are given in Table 1. The short-circuited impedance, equivalent resistance and reactance referred to the stator side, rotor resistance and leakage reactance of the motor have been obtained by using the quantities provided from the short-circuited experiment. The equivalent circuit parameters calculated by using the data in Table 1 and Table 2 are shown in Table 3, Table 4.

Table 1. No load -circuited test (experimental values)

Values for No Load Test					
P_0 (W)	U_{1h} (V)	I_{10} (A)	$\cos \varphi_0$	P_{sv} (W)	n_0 (min-1)
330	386,27	3	0,16	10	1495

Table 2. Short-circuited test (experimental values)

Values for Short-Circuited Test			
P_k (W)	U_{1Kk} (V)	I_{1K} (A)	$\cos \varphi_K$
472,104	90,118	4,066	0,7431

Table 3. Equivalent circuit parameters

Z_{1K} (Ω)	Z_{1K} (Ω)	R'_2 (Ω)	X'_{1K} (Ω)
22,1638	12,811	0,865	6,405

Table 4. Equivalent circuit parameters

R_1 (Ω)	$Z_{1\sigma}$ (Ω)	$X_{1\sigma}$ (Ω)	R_{1K} (Ω)
5,676	12,335	10,952	1,73

The Matlab / Simulink Model

The Matlab/Simulink model in Fig. 2. has been constituted by using equations 5-8 where flux linkage-current relations and mechanical system equations are written for the machine.

Flux linkage-current relations:

$$V_s = R_s I_s + \frac{d\lambda_s}{dt} + \omega_s M \lambda_s, \quad (5)$$

$$V_r = R_r I_r + \frac{d\lambda_r}{dt} + (\omega_k - \omega_m) M \lambda_r, \quad (6)$$

$$\mathbf{M} = \begin{bmatrix} 0 & -1 \\ 1 & 0 \end{bmatrix}. \quad (7)$$

$$\begin{cases} \lambda_s = L_s I_s + L_m I_r, \\ L_s = L_m + L_{sl}, \\ \lambda_r = L_r I_r + L_m I_s, \\ L_r = L_m + L_{rl}. \end{cases} \quad (8)$$

Mechanical system equations are:

$$T_e = j \frac{d\omega_{mec}}{dt} + B_m \omega_{mec} + T_L, \quad (9)$$

$$\omega_{mec} = \frac{2}{p} \omega_m, \quad (10)$$

$$T_e = \frac{3}{2} \frac{p}{2} \left(\frac{1}{L_m} \lambda_r \otimes \lambda_s \right), \quad (11)$$

$$L'_m = \frac{\sigma}{1-\sigma} L_m, \quad (12)$$

$$\sigma = 1 - \frac{L_m^2}{L_s L_r}, \quad (13)$$

where V – voltage space vector; i – current space vector; R – resistance; λ – flux linkage space vector; L – inductance; ω_s – base frequency; ω_k – speed of dq frame; ω_m – rotor speed; T_e – electromagnetic torque; T_L – load torque; J – moment of inertia, p – number of poles; M – rotational operator, subscripts: s – stator; r – rotor; d – direct axis; q – quadrature axis.

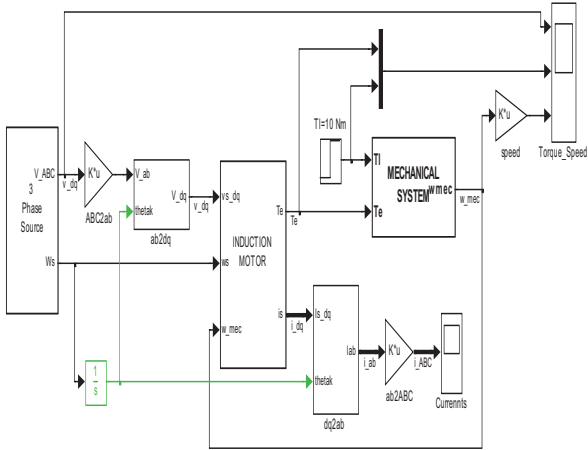

Fig. 2. Matlab/Simulink model of the system

A comparison of performances of the induction machine fed from balanced and unbalanced supplies

If balanced 3-phase alternating current machines are fed from balanced three phase power systems, symmetrical phase voltages and currents are provided. In case of operating at unbalanced voltage system, in order to obtain the amplitude of any phase current, the effects of currents in the other phases to that phase should be known. The voltage and current value of the motor 10 Nm load under experiment fed from the balanced voltages and current value are: $V_1 = 225 \angle 0^\circ V$, $V_2 = 224 \angle -120^\circ V$,

$$V_3 = 223 \angle -240^\circ V, \quad I_1 = 4.3 \angle -21^\circ A, \quad I_2 = 3 \angle -295^\circ A, \\ I_3 = 5.4 \angle -295^\circ A.$$

However if the unbalanced voltage and current systems are resolved into the symmetrical components, two circle diagrams can be obtained where they are for the forward and the reverse. Zero component does not exist since the neutral point of the motor is not grounded in normal operation [1]

The phasor values of the applied voltages unbalanced in experimental tests are: $V_1 = 225 \angle 0^\circ V$, $V_2 = 213 \angle -247^\circ V$, $V_3 = 236 \angle -126^\circ V$, $I_1 = 4.3 \angle -21^\circ A$, $I_2 = 3 \angle -295^\circ A$, $I_3 = 5.4 \angle -167^\circ A$ measured.

The voltage sources are identical in the experiment and the model. The current values have been measured while supplying the motor by the voltages shown in The voltage waveforms applied to the model in Matlab/Simulink are also given in Fig. 3.

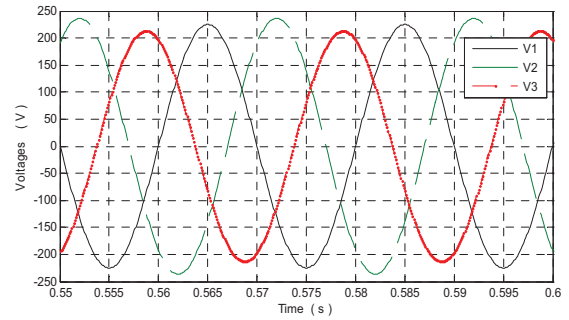

Fig. 3. Voltage for unbalanced power supply (Model)

The electrical and mechanical torque variations at 10 Nm load under unbalanced conditions are shown in Fig. 4. Under this load, the speed variation of the motor is also illustrated in Fig. 5. The all results obtained by modeling and experiments can be seen in Fig. 4 – Fig. 9.

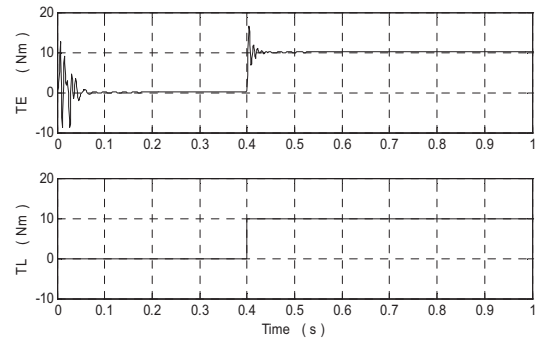

Fig. 4. Electrical and load torque at unbalanced power supply

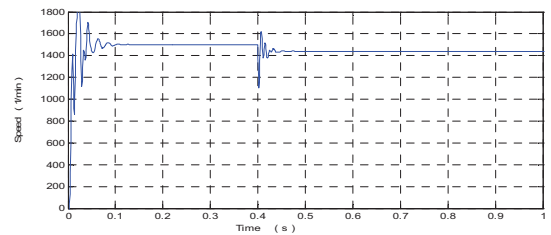

Fig. 5. Speed waveform for unbalanced power supply

Operation Status	Balanced	Unbalanced
P_2 (kW)	0,74	0,42
P_3 (kW)	0,71	0,95
$\text{Cos}\phi_1$	0,83	0,93
$\text{Cos}\phi_2$	0,82	0,67
$\text{Cos}\phi_3$	0,82	0,75

A comparison of performances of the induction machine fed from balanced and unbalanced supplies

If balanced 3-phase alternating current machines are fed from balanced three phase power systems, symmetrical In case of balanced supply, harmonics (11, 15, 19) do not exist obviously but the 3rd, 5th and 7th harmonics have influence in unbalanced operation. This result increases the total harmonic distortion and aggravates the quality of energy.

Conclusions

The unbalanced operation regime of a three phase supply is determined by quantities such as emf, potential difference and current. In this article, the specific equivalent circuits of an induction machine are obtained by resolving the mentioned quantities into symmetrical components. In these equivalent circuits, the opposite rotating torque occurs due to the reverse components of currents. Therefore the motor needs drawing more current from the supply to maintain the demanded mechanical power. As a result, the copper losses and the heat in the machine increase.

This result has been also seen by loading the machine at 10 Nm torque in both simulation and experimental measurements. In addition, the harmonics generated during

unbalanced operation are observed as electromagnetic noise in the machine. This noise appears as pulsations in motor bearings as well. This event may cause bearing faults for-long term operations from unbalanced supply. It is clearly observed that the simulation and the experimental results are in well accordance with each other. The parameters of an induction machine operating from unbalanced supply can be obtained by the proposed model in Matlab/Simulink environment without the need for any equipment.

References

1. **Bukšnaitis J.** Methods for Determination of Winding Factors of Alternating-Current Electric Machines // *Electronics and Electrical Engineering*. – Kaunas: Technologija, 2009. – No. 1 (89). – P. 83–86.
2. **Bounadja M., Belmadani B., Belarbi A. W.** A Combined Stator Vector Control – SVM-Direct Torque Control for High Performance Induction Machine Drives // *Electronics and Electrical Engineering*. – Kaunas: Technologija, 2009. – No. 8(96). – P. 51–54.
3. **Kersting W. H.** Phase Frame Analysis of the Effects of Voltage Unbalance on Induction Machines // *IEEE Transaction on Industry Applications*, 1997. – Vol. 33. – No. 2.
4. **Pillay P., Hofmann P., Manyage M.** Derating of Induction Motors Operating With a Combination of Unbalanced Voltages And Over or Undervoltages // *IEEE Transaction on Energy Conversion*, 2002. – Vol. 17. – No. 4.
5. **Stankovic A. M., Sanders S. R., Aydin T.** Dynamic Phasors in Modeling and Analysis of Unbalanced Polyphase AC Machines // *IEEE, Transaction on Energy Conversion*, 2002. – Vol. 17. – No. 1.
6. **Romaškevičius O., Šiožinys M., Virbalis J. A.** The Influence of Exciting Current Unbalance to Parameters of Magnetic Field // *Electronics and Electrical Engineering*. – Kaunas: Technologija, 2008. – No. 3(83). – P. 85–88.

Received 2010 10 12

I. Temiz, C. Akuner, H. Calik. Analysis of Balanced Three-Phase Induction Motor Performance under Unbalanced Supply using Simulation and Experimental Results // *Electronics and Electrical Engineering*. – Kaunas: Technologija, 2011. – No. 3(109). – P. 41–45.

Induction motors are known to affect the electrical power system in terms of harmonics. Induction motors fed by unbalanced power systems produce additional current harmonics. These harmonics cause additional power losses in the machine. The method of symmetrical components is often used in this kind of unbalanced operation analysis. In this study, the performance of a three phase induction motor supplied by unbalanced power system due to the various causes has been examined using both experimental method and Matlab/Simulink model. Ill. 11, bibl. 6, tabl. 6 (in English; abstracts in English and Lithuanian).

I. Temiz, C. Akuner, H. Calik. Balansinio trifazio asinchroninio elektros variklio našumo modeliavimas ir eksperimentinis tyrimas nebalanso sąlygomis // *Elektronika ir elektrotechnika*. – Kaunas: Technologija, 2011. – Nr. 3(109). – P. 41–45.

Asinchroniniai varikliai yra veikiami srovės harmonikų. Parazitinių srovės harmonikų gali atsirasti, kai asinchroninis variklis maitinamas iš nesubalansuotos maitinimo sistemos. Dėl parazitinių harmonikų patiriama galios nuostolių. Simetrinių komponentų metodas dažnai taikomas nebalanso sąlygoms tirti. Atliktas balansinio trifazio asinchroninio elektros variklio našumo modeliavimas programų paketu Matlab ir eksperimentinis tyrimas nebalanso sąlygoms. Il. 11, bibl. 6, lent. 6 (anglų kalba; santraukos anglų ir lietuvių k.).