

BER Performance of a Lumped Single-pump Fiber Optical Parametric Amplifier in a 10 Gbit/s 4-channel S-band DWDM System

A. Ščemeļevs, J. Poriņš

Institute of Telecommunications, Riga Technical University,

Azenes str. 12, LV-1010 Riga, Latvia, phone: + 371 67089245; e-mail: a.scemelevs@inbox.lv

Introduction

Fiber optical parametric amplifiers (FOPAs) have recently received a huge attention due to the fact that they can potentially be utilized in DWDM systems for light amplification and other applications, like wavelength conversion. There are numerous advantages of FOPAs over broadly used conventional EDFAs (erbium doped fiber amplifiers), the main one being the ability to tune the amplification wavelength region of FOPAs which is not possible with EDFAs, whose gain bandwidth is constant and is limited between 1530 and 1565 nm. This feature of FOPAs makes it possible to utilize them for light amplification in S (1460 to 1530 nm) and L (1565 to 1625 nm) optical bands. Considering the fact that there are new types of optical fibers available that have low loss in this two bands, the number of DWDM channels in the new generation of optical networks can increase significantly, hence increasing the data transfer rate over a single fiber.

However, there are also numerous limitations of FOPAs that need to be overcome to make their real-life application feasible. The main problem is that the gain curve of FOPAs varies considerably with different parameters of optical fibers, like zero-dispersion wavelength, PMD and temperature. The gain curve also depends on the pump laser power and wavelength and the type and length of the optical fiber utilized to stimulate the process of parametric amplification. These dependencies are investigated throughout this paper with correlation to each other by means of computer simulations.

Experimental setup

Fig. 1 shows a 4-channel system with 10 Gbit/s per channel data rate and one lumped FOPA. The frequencies of channel carriers are ITU-T standardized 196.9, 197, 197.1 and 197.2 THz, which corresponds to wavelengths in the S-band. Each channel is an NRZ transmitter, based on a 1 mW CW laser and a Mach-Zehnder modulator. CW lasers are modulated using different pseudorandom binary sequences at 10 Gbit/s bitrate. Four modulated signals are

multiplexed with a 4 to 1 optical multiplexer and then amplified to 16.5 dBm with an EDFA booster.

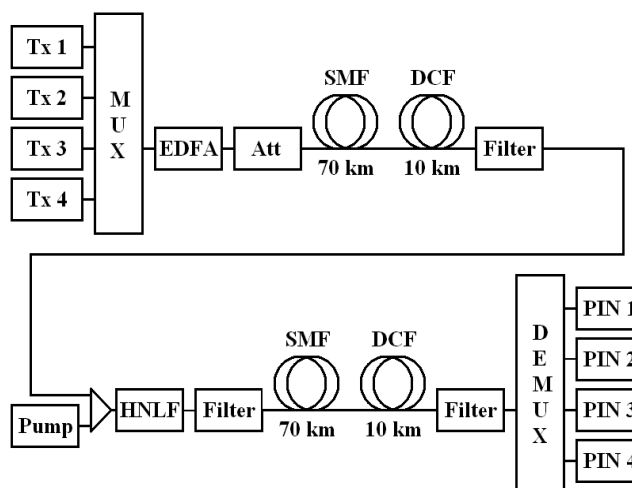

Fig. 1. 4-channel DWDM system with one lumped FOPA

Next is an optical attenuator, which is used to allocate a 6 dB margin as it is typically done during the lightwave system design process [1]. The fiber is a 70 km long standard single-mode fiber (SMF) followed by 10 km of dispersion compensating fiber (DCF) to avoid dispersion accumulation throughout the system. A 5 nm optical bandpass filter with a 197.05 THz center frequency is used before each amplification stage to suppress idler waves on new frequencies that are generated through the process of four-wave mixing. These waves would otherwise be amplified in a FOPA decreasing performance of the entire system dramatically.

The FOPA itself consists of a pump laser, an optical combiner and a highly nonlinear fiber (HNLFF). The pump is a CW laser with one to several watts power and external phase modulation at a frequency of approximately 1 GHz. The modulation is necessary to broaden the spectrum of the pump laser and reduce the harmful effect of Brillouin scattering [3]. The signal and the pump are multiplexed and introduced into HNLFF through an optical combiner.

All the pump and HNLFF parameters are chosen so that

to maximize amplification of the DWDM signal while keeping the gain curve flat. The pump frequency is 195.65 THz which makes all the harmful idler waves appear between DWDM channels and therefore decreases the negative effect of idler waves [7].

In our simulated experimental setup we use OFS highly nonlinear fiber with the following parameters:

Table 1. HNLF parameters

Nonlinear coefficient, $(W \cdot km)^{-1}$	11.5
Effective area, μm^2	11.7
Attenuation (at 1550 nm), dB/km	0.9
Zero-dispersion wavelength, nm	1510

The dispersion slope of the OFS highly nonlinear fiber in the zero-dispersion wavelength region is very flat satisfying the phase matching condition necessary for the four-wave mixing phenomenon [2,8]. The typical HNLF length we use in our experiments is several hundred meters, the precise value depending on the necessary gain and the pump power. Another optical filter is used right after the amplifier to suppress idler waves and the remaining pump wave. Fig.2 illustrates the spectrograms of the optical signal after amplification: a) before filtering; b) after filtering. This figure shows that filtering the optical signal at this stage is vital for the system to work – the pump power remaining after the process of amplification is still very high and needs to be filtered out.

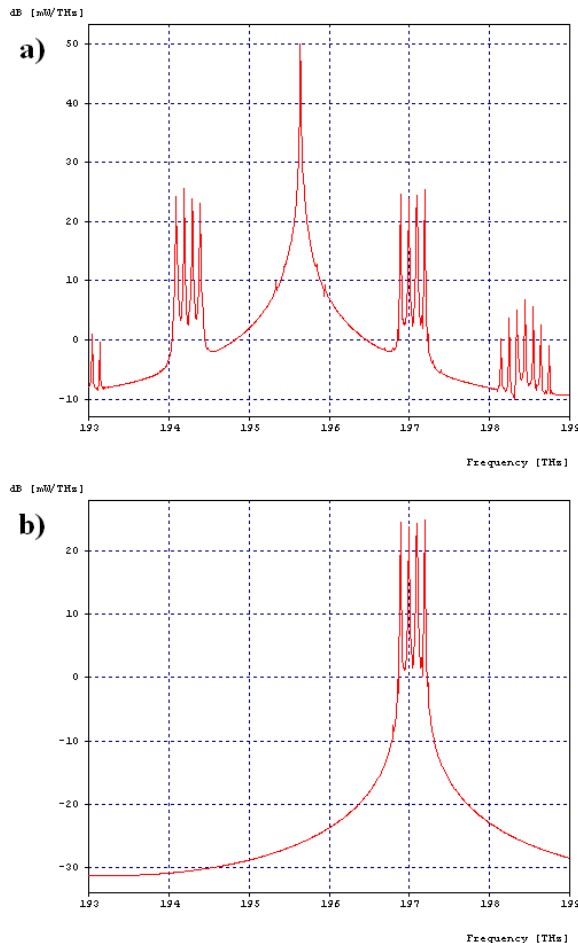

Fig. 2. The spectrum of amplified DWDM signal: a) before filtering; b) after filtering

At the receiver we use PIN photodiodes with BER and eye diagram analyzers to evaluate the impact of FOPA on the signal quality.

Results

Utilizing a system with a single FOPA amplification stage we found a relationship between the length of HNLF and the pump power. This relationship resembles an exponential decay and is illustrated in Fig.3. The idea of the simulated experiment was to find the lowest values of the two parameters that satisfy $BER \leq 10^{-12}$ criterion for all four channels simultaneously. The computations were made in two ways: at first it was a single 80 km span and then the computations were made with the same system parameters for two 80 km spans and a FOPA in between them (see Fig.1). Changing the pump power from 29 to 36 dBm with 1 dBm step we found the minimal values of HNLF length, that satisfied the criterion for all the channels.

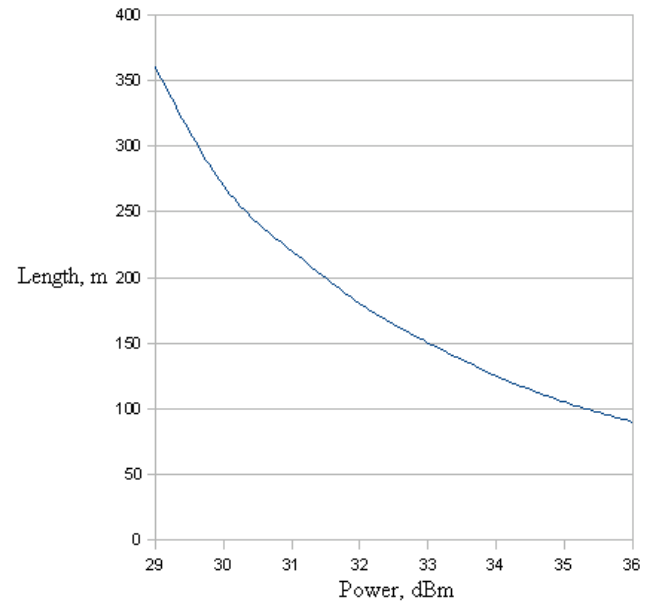

Fig. 3. The relationship between HNLF length and the pump power ($BER \leq 10^{-12}$ criterion)

Fig.3 shows the minimal values of HNLF length and the pump power, i.e. the lower limit of the two parameters. In the case when the parameters are above the curve there is enough amplification to satisfy $BER \leq 10^{-12}$ criterion for all four channels. However, we found that there is also the upper limit. This can be explained with the fact that too much amplification deteriorates the signal quality by amplifying idler waves that appear as noise. As a result both limits must be considered during the amplifier design process.

Next what we did was the investigation of lightwave systems with multiple FOPA amplification stages. We used pumps with 30 dBm power and 270 m of HNLF in each FOPA. The results proved to be really optimistic: we achieved the necessary performance ($BER \leq 10^{-12}$ criterion) for a system with four amplification stages, which equals 400 km without regeneration of the optical signal. Actually, the system with six FOPAs (560 km) showed $BER \leq 10^{-12}$ performance for three of the channels, while the fourth one

had $BER \leq 10^{-10}$.

The limiting factor in our experiments was dispersion. Though we used DCF for dispersion compensation we still had a major decrease in signal quality at the end of the link. Eye diagrams of all four channels can be seen in Fig.4.

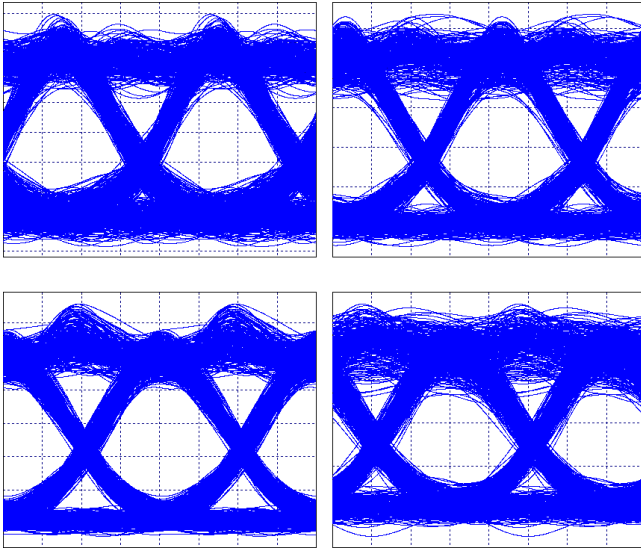

Fig. 4. Eye diagrams of 4 channels after 400 km without the optical signal regeneration

We achieved the maximum distance of 400 km, before the optical signal regeneration was needed for 4-channel DWDM system. And we had only one channel degrading below $BER \leq 10^{-12}$ for longer distances (up to 560 km). The main limiting factor in our case was dispersion. In our experiments we didn't use any kind of dispersion compensation techniques used in real lightwave systems, except for the DCF, therefore the real-life performance can be expected to be better in terms of BER performance.

Discussion

There are three basic optical amplifier parameters to be mentioned – gain, gain bandwidth and amplifier noise performance. In most of the recent papers on FOPAs the first two of them are considered without correlation to the third one and vice versa [4,5,6,9]. However, when an amplifier is used in telecommunications all three parameters must be taken into account simultaneously when evaluating performance and reliability of a lightwave system. In this case BER is the appropriate parameter, because it depends on all three parameters and it also characterizes each channel individually in case of a multichannel system.

During our research work we found there is a fundamental problem of multistage lightwave systems with FOPAs – the optical signal has to be equalized after a certain number of amplifiers, utilizing unique specially tuned optical filters. The reason for this is the fact that the gain of a WDM channel in FOPA depends on many uncorrelated factors and thus can be predicted only with a limited accuracy. The difference between the gain of the most and the least amplified channels may vary and even

with an accurately designed amplifier may reach one to several dB per amplification stage. Moreover, the FOPA gain increases with the input power of a channel, that's why the most amplified channels will continue to receive more gain with each consequent stage. As a result, after a relatively small number of amplification stages certain channels may have an inadmissibly large accumulated gain, increasing inter-channel crosstalk, nonlinear effects and the phenomenon known as cross gain modulation (XGM) and thus impairing the signal quality.

Optical filters may solve the problem of unequally amplified channels in a WDM signal. However, comparing to EDFAs, whose constant gain curve is flattened utilizing standardized optical filters, the gain curve of a FOPA with fixed parameters will vary depending on the number of input WDM channels, their wavelengths and power. This means that for each lightwave system equalizing filters will be unique and their exact parameters will have to be found during the system design and implementation process. Still it is possible that in case of a large number of WDM channels the necessary filter curves will be too complicated to realize.

Conclusion

The results of our research work proved once again the huge potential of FOPA utilization in lightwave systems. However, a number of conditions must be defined before attempting to use FOPAs in real-life. First, it is necessary to determine the acceptable boundaries for HNLF length and the pump power for each type of fiber optical parametric amplifier. Second, the accurate filtering must be done to avoid unequal amplification of channels in the system. Third, FOPA performance is very sensitive towards such characteristics of DWDM systems as the number of channels, the power of each channel at the amplifier input and the necessary gain.

References

1. **Agrawal G.** Fiber-Optic Communications Systems, Third Edition. – Academic Press. – 2002
2. **Arismar Cerqueira S. Jr, Chavez Boggio J. M., Rieznik A. A., Hernandez-Figueroa H. E., Fragnito H. L., Knight J. C.** Highly efficient generation of broadband cascaded four-wave mixing products // Optics Express. – 18 February 2008. – Volume 16, Issue 4.
3. **Chavez Boggio J. M., Callegari F. A., Marconi J. D., Guimaraes A., Fragnito H. L.** Influence of zero dispersion wavelength variations on cross-talk in single-pumped fiber optic parametric amplifiers // Optics Communications. – 8 December 2004. – Vol. 242, No. 4–6. – P. 471–478.
4. **Chavez Boggio J. M., Guimaraes A., Callegari F. A., Marconi J. D., Fragnito H. L.** Q penalties due to pump phase modulation and pump RIN in fiber optic parametric amplifiers with non-uniform dispersion // Optics Communications. – 15 May 2005. – Vol. 249, No. 4–6. P. 451–472.
5. **Chavez Boggio J. M., Marconi J. D., Fragnito H. L.** Crosstalk in double-pumped fiber optic parametric amplifiers for wavelength division multiplexing systems // Optics Communications. – 1 March 2006. – Vol. 259, No. 1. – P. 94–

- 103.
6. **Mingyi Gao, Chun Jiang, Weisheng Hu, Jingyuan Wang, Hongliang Ren.** The effects of pump noise on noise characteristics of fiber optical parametric amplifiers // *Optics Communications*. – 1 October 2006. – Vol. 266, No. 1. – P. 181–186.
 7. **Mussot A., Lantz E., Durercu-Legrand A., Simonneau C., Bayart D., Maillotte H., Sylvestre T.** Simple methods for crosstalk reduction in fiber optical parametric amplifiers // *Optics Communications*. – 15 July 2007. – Vol. 275, No. 2. – P. 448–452.
 8. **Tang R., Lasri J., Devgan P., Grigoryan V., Kumar P.** Gain characteristics of a frequency nondegenerate phase-sensitive fiber-optic parametric amplifier with phase self-stabilized input // *Optics Express*. – 26 December 2005. – Vol. 13, No. 26.
 9. **Yu Tian, Xiaosheng Xiao, Shiming Gao, Si Lu, Changxi Yang.** Ultra-flat and broadband two-pump optical parametric amplifiers using a single-section highly nonlinear fiber // *Optics Communications*. – 1 July 2006. – Vol. 263, No. 1. – P. 116–119.

Received 2009 02 15

A. Ščemeļevs, J. Poriņš. BER Performance of a Lumped Single-pump Fiber Optical Parametric Amplifier in a 10 Gbit/s 4-channel S-band DWDM System // *Electronics and Electrical Engineering*. – Kaunas: Tehnologija, 2009. – No. 5(93). – P. 11–14.

Results on computer simulations of a lumped single-pump FOPA (fiber optical parametric amplifier) are presented. We demonstrate optical amplification of a 10 Gbit/s 4-channel S-band DWDM system utilizing a lumped FOPA on a 400 km long link with 80 km long inter-amplifier spans. In most of the recent papers in the field of fiber optical parametric amplifiers research the amount of amplification and the gain bandwidth are considered as the FOPA parameters. We evaluate the effectiveness of FOPA through BER parameter, which depends on both the attenuation of optical signal and the quality degradation due to dispersion, crosstalk and amplifier noise, and therefore is more suitable for evaluation of optical amplifiers in lightwave systems. Ill. 4, bibl. 9 (in English; abstracts in English, Russian and Lithuanian).

A. Щемелев, Ю. Порињш. Исследование BER характеристики волоконно-оптического параметрического усилителя с одним лазером накачки в 10 Гбит/с в 4-канальной DWDM системе S-диапазона // *Электроника и электротехника*. – Каунас: Технология, 2009. – № 5(93). – С. 11–14.

Представлены результаты исследования волоконно-оптического параметрического усилителя с одним лазером накачки, проведенны при помощи компьютерного эксперимента, и продемонстрировано оптическое усиление в 10 Гбит/с в 4-канальной DWDM системе S-диапазона на линии длиной 400 км с участками между усилителями – 80 км. В большинстве последних работ по теме исследования волоконно-оптических параметрических усилителей главными параметрами усилителей считаются величина усиления и ширина полосы усиления. Мы оцениваем эффективность работы усилителей при помощи BER параметра, который зависит от затухания оптического сигнала и ухудшения его качества из-за дисперсии, переходных помех и шума усилителя, поэтому является более приемлемым параметром для оценки характеристик оптических усилителей в волоконно-оптических линиях связи. Ил. 4, библи. 9 (на английском языке; рефераты на английском, русском и литовском яз.).

A. Ščemeļevs, J. Poriņš. Vieną lazerinį šaltinį turinčio optinio parametrinio stiprintuvo BER tyrimas 10 Gbit/s 4 kanalų S-diaapazono DWDM sistemoje // *Elektronika ir elektrotechnika*. – Kaunas: Tehnologija, 2009. – Nr. 5(93). – P. 11–14.

Pateikti vieną lazerinį šaltinį turinčio optinio pluošto parametrinio stiprintuvo (FOPA) kompiuterinio modeliavimo rezultatai. Pademonstruotas 10 Gbit/s 4 kanalų S diapazono DWDM sistemos, naudojančios FOPA 400 km ilgio kanale su 80 km ilgio segmentais tarp stiprintuvų, optinis stiprinimas. Ankstesniuose šios srities darbuose stiprinimas ir stiprinamų dažnių juosta buvo laikomi esminiais FOPA parametrais. FOPA efektyvumą rekomenduojame vertinti pagal BER parametą, kuris priklauso nuo optinio signalo slopinimo ir jo kokybės mažėjimo veikiant dispersijai, tarpusavio triukšmams, stiprintuvo triukšmui. Dėl šios priežasties metodas geriau tinka optinių duomenų perdavimo sistemų efektyvumui vertinti. Il. 4, bibl. 9 (anglų kalba; santraukos anglų, rusų ir lietuvių k.).