

Weight and Size Estimation of Energy Efficient LED Ballasts

I. Galkin, O. Teteryonok, I. Milashevski

*Institute of Industrial Electronics and Electrical Engineering, Riga Technical University
Kronvalda boulevard 1-324, LV-1010 Riga, Latvia, phone: +371 67089918, e-mail: gia@eef.rtu.lv*

crossref <http://dx.doi.org/10.5755/j01.eee.120.4.1453>

Introduction

At the given time, the demand for electrical energy is growing while prospects of new electrical energy sources are quite questionable. This requires for an increase in energy efficiency that, in turn, can be achieved through increasing of self-efficiency of electrical technologies. Another way is making electrical equipment “smart” that means reasonable limitation of its operation. In particular, in the field of electrical lighting these two ways can be combined if Light Emitting Diodes (LEDs) are used [1]. On the one hand modern LEDs have efficacy of several tens lumens per watt that is comparable with high pressure sodium lamps. On the other hand it is possible to effectively adjust the light produced by LEDs with no negative impact on them. This paper estimates the efficiency of various LED ballasts in the context of optimization of their weight and size.

Amount of light produced by an LED is proportional to its current. This brings forward two light control methods [2]: 1) fluent regulation of LEDs current - when its value varies depending on the light request; 2) pulse mode regulation of LEDs current - when it is either zero or maximum but its average value varies depending on the light request. Since the light produced by LED follows its current at a very high rate [3] the second method may lead to flickering and stroboscopic effects. One more light regulation method [2] is possible because rated power of LEDs is usually small. For this reason LED luminary usually includes a number of LEDs. Then it is possible to divide them into groups and control each group separately. This method, however, ensures lesser dimming levels and lower accuracy of regulation. Therefore, the first regulation method – fluent regulation of LED current is preferable.

LED itself is a low voltage element. This mostly requires a DC/DC stage for dimming even if the LED luminary is fed from AC line. This argument is especially significant if the luminary has few LED groups that must be dimmed separately, for instance, in the case of street lighting. Various DC choppers can be used as the

regulators: buck, boost, buck-boost etc [4]. All these converters are pulse mode circuits that may be driven in different ways – pulse width modulation, frequency modulation etc. The chosen topology and control method has significant impact on the efficiency of the dimmer [5]. They also have influence on its size and weight.

The given paper investigates buck and boost dimmers operating in pulse width modulation mode from the point of view of weight/size and efficiency. The converters are estimated analytically and through simulation as well as tested experimentally. Then the conclusions about the optimal choice are formulated at the end.

General considerations

Weight and size of any electronic converter depend on those of its elements. However, from this point of view some elements are dominating over the others and their contribution has to be taken into account first. The most significant components of one-switch DC/DC dimmers are inductance coil, power diode and power transistor together with their heatsink (whose size depends on the power losses) and driver. Previous experience shows that they take up to 50% of the total volume and up to 40% of the total weight. That is why this paper is focused on the estimation of these elements.

In this research buck and boost topologies of the dimmers has been investigated due to their potentially better control performance.

Schematics of experimental setup for buck converter is shown in Fig. 1-a, but for boost – in Fig. 1-b. All elements of the testbench (VT1 – IRF540 MOSFET, VD1 – ultrafast diode MUR860, and the load containing seven series connected LEDs W724C0 made by Seoul Semiconductor) were the same during all experiments to ensure that difference of measured values between tests depends only on inductor parameter changes. Values of inductance coil L_{SM} were changed during experiments. Several values of the switching frequency have been applied as well. The output power has been used as an

argument for output curves.

Control signal have been obtained from a function generator G1 and fed to VT1 transistor through HCPL-J312 driver. To carry out measurements four Extech EX430 multimeters were used with 0.3% basic accuracy.

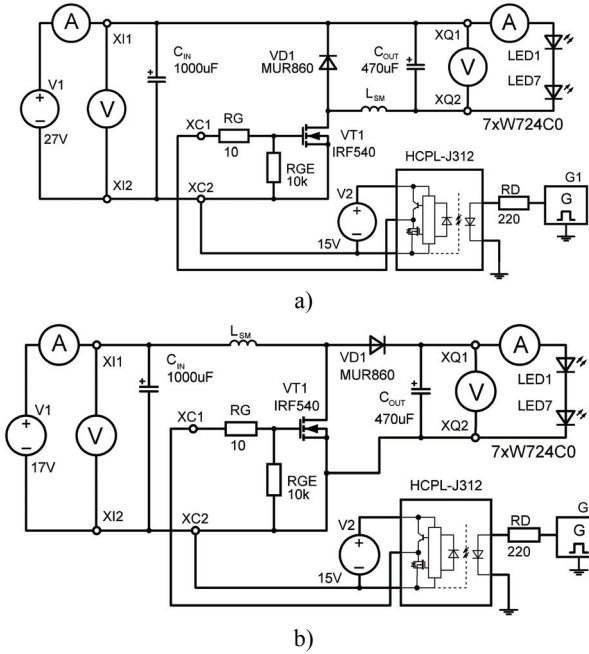

Fig. 1. Testbench for evaluation of dimmers for light regulation with LEDs: a – buck configuration; b – boost configuration

Estimated influence of parameters

Expected influence of the dimmer type. If the choice of input voltage for dimmer is not limited then the dimmer can also be quite arbitrarily chosen. In this case the impact of topology of the dimmer on its weight/size may be the main criterion for its choice. At the same time it must be noted that the influence of the topology is not direct.

The utilized diodes W724C have operating voltage of 2.5...3.6V that corresponds to operating current 0...2.8A. Therefore seven such diodes require from 17.5 to 25V for full range of current regulation. Such voltage can be obtained from a buck, boost or buck/boost converter. The last one does not provide good performance from the point of view of control and is not discussed here. The buck dimmer operates better (from the same point of view) at 25V input and requires 70...100% of duty cycle in this case. Similarly the boost dimmer must have 17.5V on its input and 0...30% of the duty cycle. Therefore, the first dimmer works with higher on-state losses in the switch while the second one – in the diode.

The expressions required for calculation of power losses in buck and boost dimmers (Table 1) are based on the power equilibrium for input voltage V_{IN} and output current I_O . It is also assumed that the inductance of the coil is infinite – i.e. the switch and diode conducts pulse mode current. Nonlinearity of LED load is represented as no consumption at voltage less 17.5V and linear load 0...3A corresponding to voltage of 17.5...25 V

$$I_O = \frac{V_O - 17.5V}{25V - 17.5V} \cdot 3A. \quad (1)$$

Table 1. Calculation losses of buck and boost dimmers

Conv.	$V_O(1)$	$I_L(2)$	$P_{VD}(3)$	$P_{VT}(4)$
Buck (A)	$V_{IN} \cdot D$	I_O	$V_{VDon} \cdot I_O \cdot (1-D)$	$R_{VTon} \cdot I_O^2 \cdot D$
Boost (B)	$\frac{V_{IN}}{1-D}$	$\frac{I_O}{1-D}$	$V_{VDon} \cdot \frac{I_O}{1-D} \cdot (1-D)$	$R_{VTon} \cdot \left(\frac{I_O}{1-D}\right)^2 \cdot D$

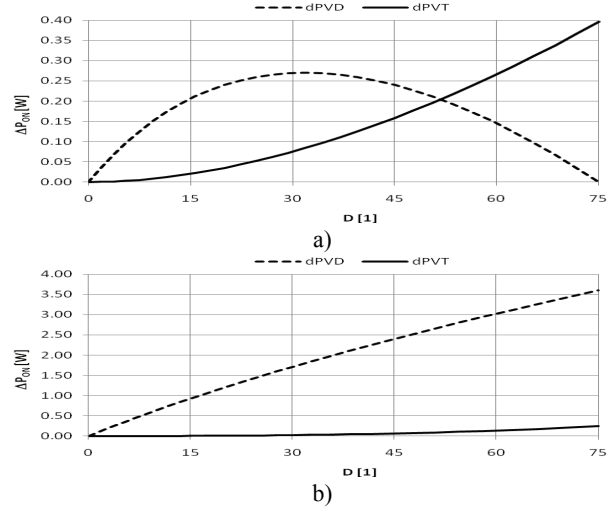

Fig. 2. On-state losses of power diode and transistor in DC/DC LED dimmers: a – buck; b – boost

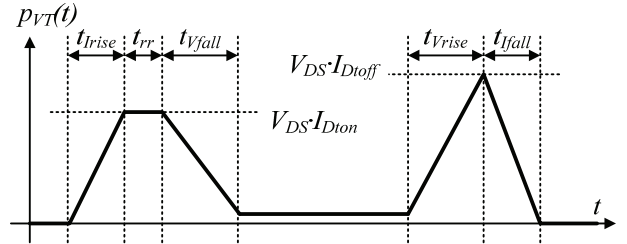

Fig. 3. Instantaneous power losses of a MOSFET transistor operating in a conjunction with a diode

Utilizing (1) and equations from Table 1 it becomes possible to calculate the power losses and present them graphically (Fig. 2). This picture demonstrates that, as it has been previously noted, in the buck converter on-state losses of the transistor dominates at high duty cycles, while in the buck – diode losses are more significant. Besides that it is obvious that the on-state losses of the boost converter are higher in absolute value (mostly due to diode losses). Indeed, if power of converters is the same then the boost converter has much higher input (coil) current that leads to higher losses in semiconductor switches.

The configuration of the dimmer has impact on its switching losses too. The technology of calculation of these losses is given in [6]. In slightly simplified version (for the worst case analysis) it is represented by the following formulas (see Fig. 3 for details):

$$\Delta P_{VT} = (E_{VTon} + E_{VTtoff}) \cdot f_{SW}, \quad (2)$$

$$\Delta P_{VD} = (E_{VDrr} + E_{VDtoff}) \cdot f_{SW} \approx E_{VDrr} \cdot f_{SW}, \quad (3)$$

$$E_{VTon} = V_{DS} \cdot I_{Dton} \cdot \frac{t_{Irise} + t_{Vfall}}{2} + Q_{rr} \cdot V_{DS}, \quad (4)$$

$$E_{VTtoff} = V_{DS} \cdot I_{Dtoff} \cdot \frac{t_{Vrise} + t_{Vfall}}{2}, \quad (5)$$

$$E_{VDrr} = \frac{V_{DS} \cdot Q_{rr}}{4}, \quad (6)$$

where voltage rise and fall times are found as:

$$t_{Vrise} \approx V_{DS} \cdot R_G \frac{C_{GD}}{V_{GSload}}, \quad (7)$$

$$t_{Vfall} \approx V_{DS} \cdot R_G \frac{C_{GD}}{V_{DR} - V_{GSload}}. \quad (8)$$

Other parameters are either known as the initial conditions (V_{DS} – is operation voltage of the switch, I_{Dton} and I_{Dtoff} – commutated current at turn-on and turn-off transients respectively, f_{SW} – switching frequency, R_G – value of gate resistor) or found from the datasheets (Q_{rr} – reverse recovery charge of the utilized diode, t_{Vrise} and t_{Vfall} – drain current rise and fall time, C_{GD} – gate to drain capacitance, V_{GSload} – gate voltage at the drain equal to load).

(2)–(8) provide a basis for switching loss calculation. However, distribution of the losses across the operation range depends on the dimmer. In the case of buck converter $V_{DS}=V_{IN}$ is a constant, but $I_D=I_O$ depends on the duty cycle as expressed in (1). Then the switching losses of the transistor rise linearly with current (Fig. 4-a).

In the boost converter $V_{DS}=V_O$, hence the losses are also a function of the duty cycle (Table 1-B1). At the same time $I_D=I_{IN}$ that can be expressed by (B2), where I_O is still expressed by (1). Therefore, in this converter transistor commutates the current that, due to power equilibrium, undergoes doubled $1/(1-D)$ effect. This leads to more strong effect of D on the switching losses (Fig. 4).

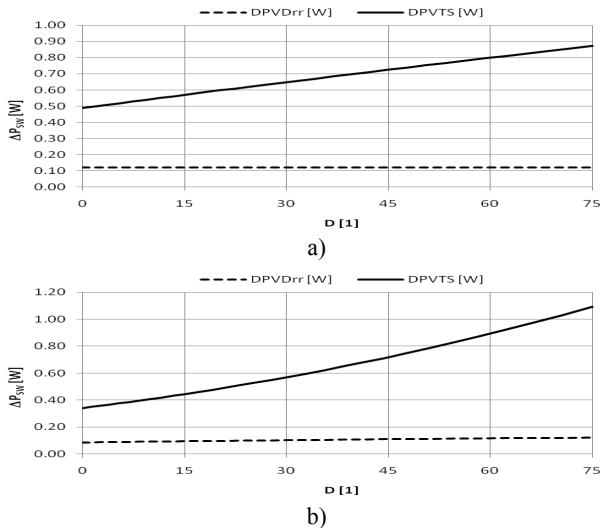

Fig. 4. Switching losses of power diode and transistor in DC/DC LED dimmers: a – buck; b – boost

Expected influence of modulation frequency. Switching losses in the diode are defined mostly by its recovery process. In the bust converter they depend on the

duty cycle D , but are still small compared with those of transistor and, especially with its on-state losses.

The impact of the switching frequency f_{SW} on the commutation losses is linear and is expressed by (2) and (3). On the other hand from Table 1-A3...B4 it is seen that this frequency has no effect on the conduction losses. If the thermal parameters of the transistor and diode are known then it is possible to determine the maximal power losses and maximal frequency of operation. For instance for no heatsink situation transistor losses are $\Delta P_{VTmax}=(175-25)/62=2.4W$ but diode losses $\Delta P_{VDmax}=(175-25)/75=2W$. Then the maximal switching losses are $2.4-0.4=2W$ for the transistor, but for the diode $2-0.27=1.73W$. From where and from (2)...(3) maximal frequency of the diode is $1.72W/1219nJ=1.41MHz$, but this of the transistor – $2W/8370nJ=0.24Mhz$. There switching energy have been found previously utilizing (4)...(6).

On the other hand increasing the frequency decreases the value of reactive components linearly while their physical volume has square-root dependence.

Expected influence of inductance. The inductance of a coil has direct impact on its volume expressed with proportionality coefficient A_L that ties the inductance of the coil and number of its turns in power 2. Therefore if the coil utilizes the available wire window well it is possible to say that the volume of the coil proportional to the square-root of its inductance.

At the same time, smaller inductance leads to higher current pulsations in the coil and, hence, in the transistor and diode. Therefore, rms current of the transistor must be higher at lower inductance. The corresponding dependence may be presented in a simplified form as following

$$I_{VTrms} = \sqrt{I_{La}^2 + \frac{K_1}{L_{SM}} + \frac{K_2}{L_{SM}^2}}. \quad (9)$$

However (9) shows that this dependence is quite weak and can mostly be ignored.

Development of model and simulation

Initial evaluation of the DC/DC buck and boost dimmer has been made through PSpice simulation. For the most of the elements a compromise between the complicity of the model and tolerance has been achieved: power diode and MOSFET are simulated as inherent PSpice models while models of the coil and LED load utilize macro-circuits based on a datasheet parameters of the elements. At the same time input voltage source, control source and driver are simulated as ideal elements.

The simulation results of the buck and boost converters are presented in this subsection. The switching frequencies through the simulation have been set to 40 kHz, 80kHz and 120kHz, but values in inductance of the coil – to 317uH, 417uH, 512uH, 610uH and the 761uH.

The comparison of efficiency is presented in Fig. 5 and Fig. 6. Efficiency at fixed value of L_{SM} and different values of frequency for buck converter is given in Fig. 5-a, but for boost – in Fig. 6-a. Efficiency at fixed value of f_{SW} different values of inductance for buck converter is given in Fig. 5-b, but for boost – in Fig. 6-b.

As can be seen from the graphs, the higher switching frequency reduces the efficiency. The highest efficiency can be observed with frequency 40 kHz.

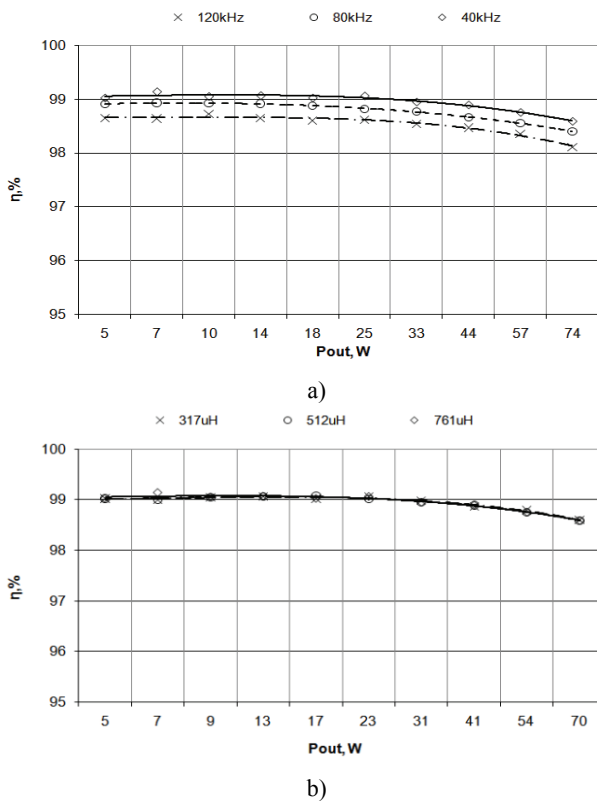

Fig. 5. Results of PSpice simulation of buck converter: a) $L_{SM}=761\mu H$, $f_{SW}=\text{var}$; b) $L_{SM}=\text{var}$, $f_{SW}=40\text{ kHz}$

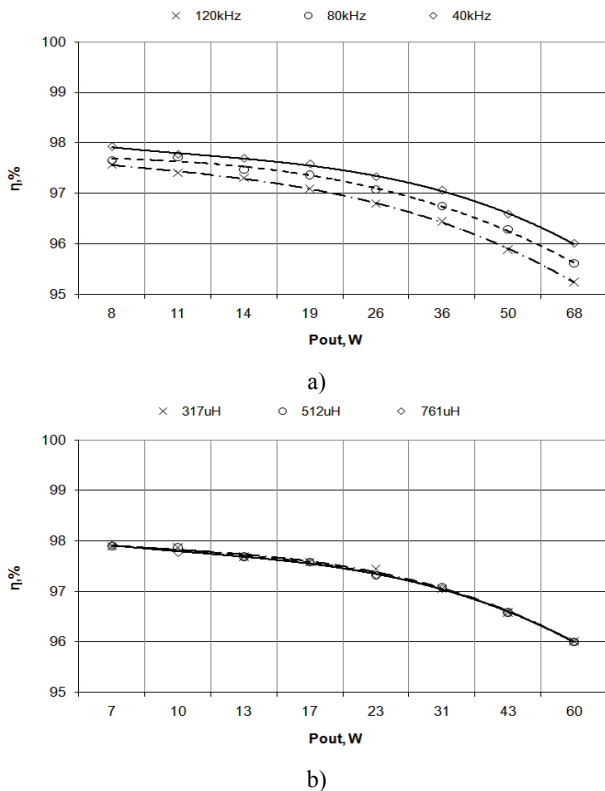

Fig. 6. Results of PSpice simulation of boost converter: a) $L_{SM}=761\mu H$, $f_{SW}=\text{var}$; b) $L_{SM}=\text{var}$, $f_{SW}=40\text{ kHz}$

According to the presented figures the influence of the inductor is quite weak. This, however, may be a result of inaccuracy of its model. A more detailed model of the inductor could reveal decreased efficiency.

Simulation results show that buck converter switching topology is a good platform for a high efficiency LED drive system, because it provides higher efficiency than the boost converter.

Experimental evaluation of the dimmers

Buck converter. Efficiency of the buck converter has been evaluated with three switching frequencies - 40, 80 and 120kHz (Fig. 7). It can be seen that the overall efficiency of the converter decreases with frequency growth. The reason is increasing switching losses in semiconductor switches, inductor core losses and conductor skin effect.

One more series of experiments has been conducted with different value of the inductance coil (Fig. 8).

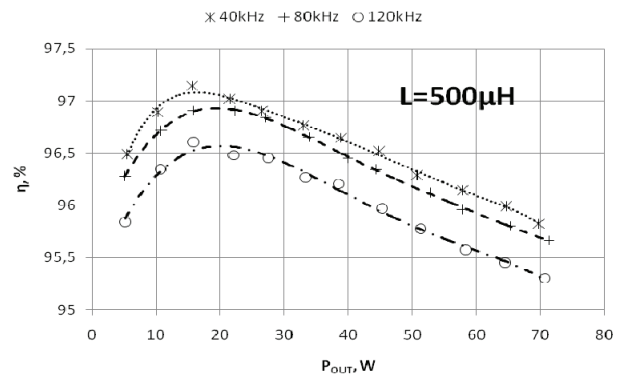

Fig. 7. Changes in efficiency of buck converter at different switching frequencies (experimental data)

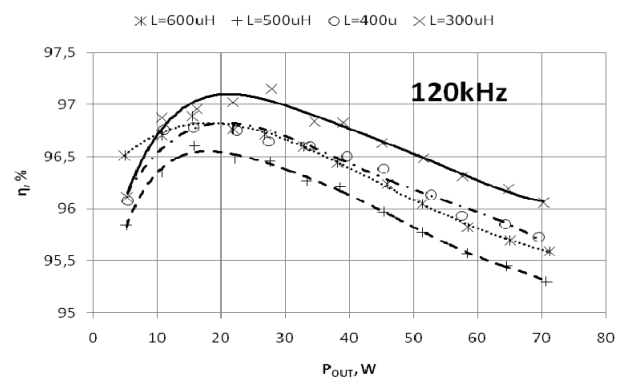

Fig. 8. Changes in efficiency of buck converter at different values of inductance coil (experimental data)

The tendency found in Fig. 8 is the same for different frequencies - efficiency curve becomes more linear at bigger inductance. Efficiency increases at smaller output powers with bigger inductance. Smaller inductances provide better performance at higher output powers because of its smaller active.

Three different cores (T94-26, T106-26 and T130-26) were used to evaluate influence the core size of a coil on its performance (Fig. 9).

Table 2. Exact parameters of inductance coil

Toroidal iron powder core T94-26		
Number of turns	Precise inductance at 25kHz, μH	Active resistance, $\text{m}\Omega$
70	314	75
80	410	87
89	507	98
98	606	110

Table 3. Exact inductor parameters for core size test

Inductance coil 300 μH		
Core size	Exact inductance at 25kHz, μH	Active resistance, $\text{m}\Omega$
T94-26	314	75
T106-26	311	75
T130-26	317	80

Table 4. Exact parameters of inductance coils for skin effect test

Toroidal iron powder core T94-26			
Precise inductance at 25kHz, μH	Wire diameter, mm	Active resistance, $\text{m}\Omega$	Number of wires
307	0,21	80	17
317	0,51	80	3
320	1,11	60	1

From Fig. 9 is seen that bigger inductor core size is better at lower output powers. At the same time at higher output power smaller core is preferable because of smaller active resistance of wires (Table 3).

Skin effect has been evaluated on the next stage (Fig. 10). This effect appears at higher frequencies and reduce effectively used conductor cross sectional area. To reduce conductor skin effect several parallel wires of the smaller diameter can be used (Table 4).

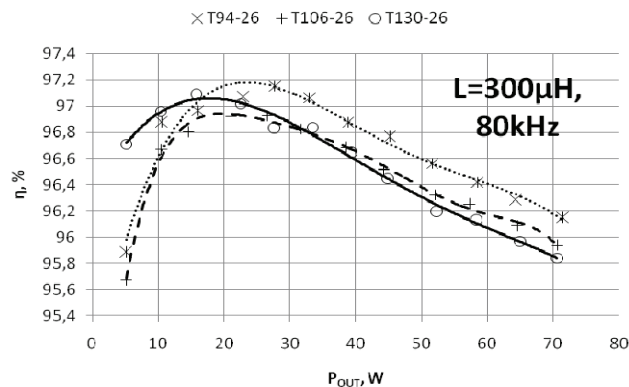

Fig. 9. Core size influence on buck converter efficiency (experimental data)

Boost converter. The analysis of experiments for boost converter shows that at higher frequency losses increases, especially at higher output power (Fig. 11). At the same time increase of inductance (Fig. 12) causes increase of losses at higher output powers. This can be explained by growth of the inductor active resistance (Table 5). Fig. 13 shows that there no significant impact of the core size.

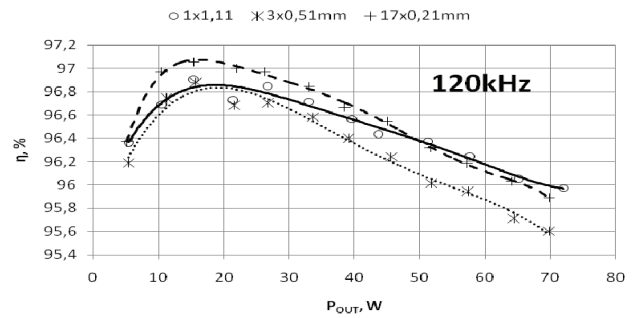

Fig. 10. Conductor skin effect influence on inductor losses (experimental data)

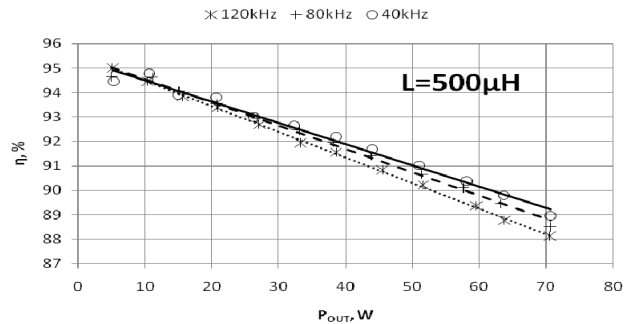

Fig. 11. Impact of switching frequency on boost converter efficiency (measured)

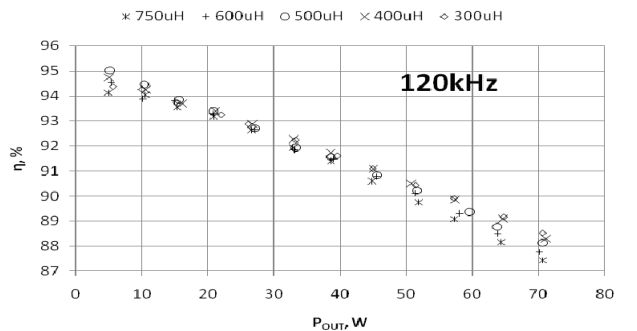

Fig. 12. Impact of inductance on boost converter efficiency(measured)

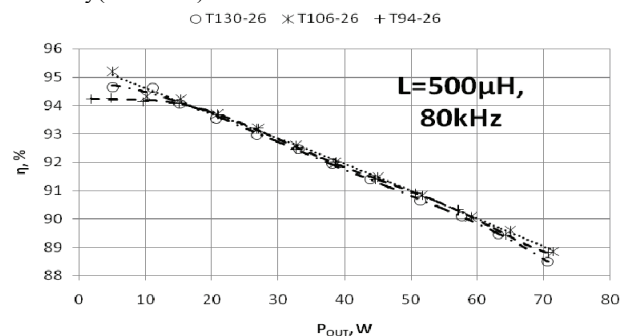

Fig. 13. Core size impact on the boost converter efficiency (experimental data)

Table 5. Exact parameters of inductance coil

Toroidal iron powder core T106-26		
Number of turns	Precise inductance at 25kHz, μH	Active resistance, $\text{m}\Omega$
64	317	88
72	417	94

Toroidal iron powder core T106-26		
Number of turns	Precise inductance at 25kHz, μH	Active resistance, $\text{m}\Omega$
80	510	105
88	612	131
98	761	151

Conclusions

The most important conclusion is that the efficiency of the discussed converters and their weight /size is much related. Losses of the semiconductor elements define the size of their heatsinks. The inductor itself has a strong contribution in the overall size of the converter.

The presented data proves that buck dimmers may be more compact because of their better overall efficiency, especially at higher output power. This can be explained by longer operation time of the transistor and shorter – of the diode. This leads to smaller conduction losses in the diode and higher but acceptable in the transistor.

Using lower frequency of operation reduces losses of semiconductor elements but requires bigger inductor and vice versa. Some compromise can be found if switches with reasonable heatsink operate at the highest heat transfer level.

Inductor has a contradictory effect on the size of converter. Bigger inductor allows reduction of frequency and losses but it is bulky itself. It must also be noted that converter efficiency at higher output power can be improved by using smaller cores that reduces resistance of the winding.

It must be specially emphasized that the impact of wire resistance of the inductor is significant. Therefore,

effective (including skin and proximity effects) cross-sectional area of the wires must be kept high enough but their length – short enough. For smaller inductances this can be achieved by using smaller inductor cores.

References

1. **Avotins A.** City Illumination Development Study // Proceedings of 8th International Symposium on Topical Problems in the Field of Electrical and Power Engineering. – Publishing House “Elektrijam”, 2010. – P. 175–179.
2. **Galkin I., Avotins A., Suzdalenko A., Ribickis L.** Comparison and Choice of Supply and Driver Unit for Power LED Luminary // Power and Electrical Engineering. – RTU, 2009. – Series 4, Vol. 25. – P.137–140.
3. **Schmid M., Kuebrich D., Weiland M., Duerbaum T.** Evaluation on the Efficiency of Power LEDs Driven with Currents Typical to Switch Mode Power Supplies // Proceedings of 42nd Industry Applications Society Annual Meeting (IAS'2007). – IEEE Electronic Publishing, 2007. – P. 1135–1140.
4. **Van der Broeck H., Sauerlander G., Wendt M.** Power driver topologies and control schemes for LEDs // Proceedings of 22nd Applied Power Electronics Conference (APEC'2007). – IEEE Electronic Publishing, 2008. – No. 1. – P. 1319–1325.
5. **Galkin I., Bisenieks L., Suzdalenko A.** Impact of Pulse Modulation Method of LED Dimmer for Street Lighting on its Efficiency // Proceedings of 4th European DSP Education and Research Conference (EDERC'2010). – Texas Instruments, 2010. – No. 1. – P. 160–164.
6. **Ren Y., Xu M., Zhou J., Lee F.C.** Analytical loss model of power MOSFET // IEEE Transactions on Power Electronics. – IEEE Publishing, 2006. – Vol. 21. – No. 2. – P. 310–319.

Received 2011 03 28

Accepted after revision 2011 07 25

I. Galkin, O. Teteryonok, I. Milashevski. Weight and Size Estimation of Energy Efficient LED Ballasts // Electronics and Electrical Engineering. – Kaunas: Technologija, 2012. – No. 4(120). – P. 55–60.

Constantly growing demand for electrical energy compels for energy efficient electrical equipment. In lighting this assumes utilization of energy effective and intellectual lighting technologies. LED lighting technology combines both of these two ways. LED elements always require some electronic ballast that may consist of a primary power supply and a number of secondary dimmers for light regulation. These circuits can be implemented as DC/DC converters. In the paper buck and boost dimmers have been investigated from the point of view of their losses, weight and size. It has been found that buck converter can be the smaller and operate with the smaller losses. Higher switching frequency is preferable while the power switches of the dimmer have to be used with reasonable heatsinks. Larger values of inductance may reduce the total dimensions in spite of additional size due to the bigger coils. III. 13, bibl. 6, tabl. 5 (in English; abstracts in English and Lithuanian).

I. Galkin, O. Teteryonok, I. Milashevski. Efektyvių LED balastų svorio ir dydžio optimizavimas // Elektronika ir elektrotechnika. – Kaunas: Technologija, 2012. – Nr. 4(120). – P. 55–60.

Nuolat didėjanti elektros energijos paklausa verčia naudoti energiška efektyvią elektros įrangą. Taikomos efektyvios ir intelektualios apšvietimo technologijos. LED apšvietimo technologija jungia abi šias sritis. LED elementams visada reikia tam tikro elektroninio balasto, kurį gali sudaryti pradinis energijos šaltinis ir keletas antrinių reguliatorių šviesai reguliuoti. Šie grandynai gali būti sukurti kaip DC/DC keitikliai. Buvo ištirti žeminantieji ir aukštinantieji reguliatoriai vertinant jų nuostolius, svorį ir dydį. Buvo nustatyta, kad žeminantysis keitiklis gali būti mažesnis ir sukelia mažiau nuostolių. Didėjant induktyvumui bendri matmenys gali mažėti, nors rikių matmenys padidėja. II. 13, bibl. 6, lent. 5 (anglų kalba; santraukos anglų ir lietuvių k.).