

Analysis of Nonlinearities in Phototransistors

J. Anilionienė

*Kaunas University of Technology, Department of Applied Mathematics,
 Studentų str. 50, LT-51368, Lithuania, Phone: +370 37 300318, E-mail: julija.anilioniene@ktu.lt*

Introduction

Using phototransistors (PHT) in different optoelectronic devices and in order to get as low signal distortions as possible, a great focus is made on investigations of nonlinearities manifesting themselves in PHT [1]. For analysis of nonlinear inertial systems with variable parameters, differential equations representing nonlinear, frequency and parametrical performances of the system are applied [2]. These complex equations, however, are solved by using digital methods that require highly considerable computer resources and time, and are suitable only in partial cases.

The aim of this paper is to evaluate nonlinearities of a phototransistor, analyze their influence on signal distortions, obtain general solutions appropriate for engineering calculations when approximate methods are used. From the latter, one of the most acceptable methods is a technique when Volterra – Wiener functional series are applied.

Model and Analysis Methodology

Using the method of Volterra – Wiener functional series, a phototransistor as a nonlinear function is composed of linear, square, cube, etc. systems connected in parallel.

The first system is linear. If signal $i_{IN}(t)$ is send to PHT, an output signal of this system is the following:

$$i_{OUT}^T(t) = \int_0^t h_{1T}(t - \tau_1) i_{IN}(\tau_1) d\tau_1 = \int_0^t h_{1T}(\tau_1) i_{IN}(t - \tau_1) d\tau_1 \quad (1)$$

or a view is as follows:

$$I_{OUT}^T(p) = H_{1T}(p) I_{IN}(p); \quad (2)$$

where p – complex variable, $i_{IN}(t) = 0$, when $t < 0$.

An output signal of the square system is

$$i_{OUT}^{KV}(t) = \iint_{00}^{tt} h_{2T}(t - \tau_1, t - \tau_2) \prod_{i=1}^2 i_{IN}(\tau_i) d\tau_i = \iint_{00}^{tt} h_{2FT}(\tau_1, \tau_2) \prod_{i=1}^2 i_{IN}(t - \tau_i) d\tau_i \quad (3)$$

or

$$I_{OUT}^{KV}(p_1, p_2) = H_{2T}(p_1, p_2) \prod_{i=1}^2 I_{IN}(p_i). \quad (4)$$

An output signal of the cube system is

$$i_{OUT}^{KB}(t) = \iiint_{000}^{ttt} h_{3T}(t - \tau_1, t - \tau_2, t - \tau_3) \prod_{i=1}^3 i_{IN}(\tau_i) d\tau_i = \iiint_{000}^{ttt} h_{3FT}(\tau_1, \tau_2, \tau_3) \prod_{i=1}^3 i_{IN}(t - \tau_i) d\tau_i \quad (5)$$

or

$$I_{OUT}^{KB}(p_1, p_2, p_3) = H_{3T}(p_1, p_2, p_3) \prod_{i=1}^3 I_{IN}(p_i). \quad (6)$$

Only three harmonics will be evaluated as already third harmonic in optical devices is very low. Then a full output signal is equal to the sum of signals of a linear, square and cube systems

$$i_{OUT}(t) = \sum_{k=1}^3 \iiint_{000}^{ttt} h_{kT}(\tau_1, \tau_2, \tau_3) \prod_{i=1}^k i_{IN}(t - \tau_i) d\tau_i, \quad (7)$$

where $h_{kT}(\tau_1, \tau_2, \tau_3)$ defines kernels of an appropriate order of Volterra functional series.

If a phototransistor receives the following signal

$$i_{IN}(t) = I_{IN} \cos(\omega t + \varphi) = \frac{1}{2} I_{IN} (e^{j(\omega t + \varphi)} + e^{-j(\omega t + \varphi)}), \quad (8)$$

change in PHT mode is defined by analyzing a square system [3]:

$$i_{OUT}^{KV}(t) = \frac{1}{2} I_{IN}^2 \operatorname{Re}(H_{2D}(jw, -jw)) + \frac{1}{2} I_{IN}^2 |H_{2T}(jw, jw)| \cdot \cos(2wt + \varphi_{2w}), \quad (9)$$

where φ_{2w} – phase of the second harmonic.

Change in the first harmonic is figured out by analyzing a cube system:

$$i_{OUT}^{KB}(t) = \frac{3}{4} I_{IN}^3 |H_{3T}(jw, jw, -jw)| \cos(wt + \varphi_w) + \frac{1}{4} I_{IN}^3 |H_{3T}(jw, jw, jw)| \cos(3wt + \varphi_{3w}), \quad (10)$$

where φ_{3w} – phase of the third harmonic.

In order to determine changes in an operation mode of a phototransistor and distortions of the transferred signals due to PHT nonlinearities, first of all they shall be evaluated.

Analytic Solutions

Phototransistor nonlinearities and their influence on dynamic parameters of the signals transferred will be analyzed.

The main PHT nonlinearities that determine the changes in a mode and the signal transferred are nonlinear junction currents of an emitter and collector and their nonlinear capacitances [4].

Fig. 1 presents an equivalent diagram of a phototransistor.

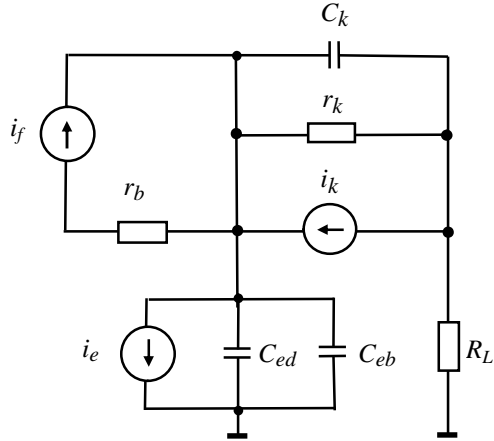

Fig. 1. Equivalent diagram of a phototransistor

Junction current of a PHT emitter is the following:

$$i_e = I_{e0} (\exp(\gamma_e u_e) - 1), \quad (11)$$

where I_{e0}, γ_e – PHT parameters, u_e – junction voltage.

After expanding (11) in a Taylor series, the following is obtained:

$$i_e = I_{e0} + \lambda_1 u_e + \lambda_2 u_e^2 + \lambda_3 u_e^3, \quad (12)$$

where I_{e0} – constant component.

$$\lambda_1 = G_e, \quad \lambda_2 = \frac{1}{2} G_e^2 / I_{e0}, \quad \lambda_3 = \frac{1}{6} G_e^3 / I_{e0}^2. \quad (13)$$

where G_e – nonlinearity conductivity, U_e – junction voltage of an emitter.

Nonlinear generator current flowing through the junction capacitance of an emitter is as follows:

$$i_{c_e} = \beta_1 du_e/dt + \beta_2 du_e^2/dt + \beta_3 du_e^3/dt, \quad (14)$$

$$\begin{cases} \beta_1 = \frac{\tau_{\alpha T} G_e}{\sqrt{2} \varphi_T} + v(\varphi_T - U)^{-\frac{1}{2}}, \\ \beta_2 = \frac{\tau_{\alpha T} G_e^2}{2\sqrt{2} I_{e0} \varphi_T} - \frac{1}{4} v(\varphi_T - U)^{-\frac{3}{2}}, \\ \beta_3 = \frac{\tau_{\alpha T} G_e^3}{6\sqrt{2} I_{e0}^2 \varphi_T} + \frac{1}{8} v(\varphi_T - U)^{-\frac{5}{2}}, \end{cases} \quad (15)$$

where $\tau_{\alpha T}, v_e$ – PHT physical parameters, φ_T – temperature potential.

Nonlinear generator current flowing through the collector capacitance:

$$i_{C_K} = \gamma_1 du_K/dt + \gamma_2 du_K^2/dt + \gamma_3 du_K^3/dt, \quad (16)$$

where U_K – junction voltage of a collector,

$$\gamma_1 = V_K U_K^{-\frac{1}{3}}, \quad \gamma_2 = \frac{1}{6} V_K U_K^{-\frac{4}{3}}, \quad \gamma_3 = \frac{2}{27} V_K U_K^{-\frac{7}{3}} \quad (17)$$

where V_K – constant.

Variable component of an output current is

$$i_K = (L_1 - pD_1)u_e + (L_2 - pD_2)u_e^2 + (L_3 - pD_3)u_e^3, \quad (18)$$

where L_1, L_2, L_3 and D_1, D_2, D_3 – coefficients dependent on PHT parameters and frequency.

After evaluation of phototransistor nonlinearities for respective units of an equivalent PHT diagram [2] kernels of a linear, square and cube systems are calculated.

Kernels of a linear system will be referred to as $H_{11T}(p)$, $H_{12T}(p)$, $H_{13T}(p)$. They correspond to the units of an equivalent PHT diagram and are figured out from a matrix equation:

$$\begin{pmatrix} H_{11T}(p) \\ H_{12T}(p) \\ H_{13T}(p) \end{pmatrix} = W^{-1}(p) \quad (19)$$

where $W(p)$ - conductance matrix.

$$W^{-1}(p) = \begin{bmatrix} \frac{1}{r_b} & -\frac{1}{r_b} & 0 \\ \frac{1}{r_b} & -\left(\frac{1}{r_b} + \frac{1}{r_k} + \lambda_1 + L_1 + (\gamma_1 + \beta_1 - D_1)p\right) & \frac{1}{r_k} + L_1 + (\gamma_1 - D_1)p \\ 0 & -\left(\frac{1}{r_k} + L_1 + (\gamma_1 - D_1)p\right) & \frac{1}{r_k} + \frac{1}{R_L} + L_1 + (\gamma_1 - D_1)p \end{bmatrix}, \quad (20)$$

where R_L - load resistance.

After figuring out a linear kernel, a current output may be calculated:

$$I_{OUT} = H_{13T}(p)I_{IN}. \quad (21)$$

Two-dimensional kernels of PHT diagram units will be marked respectively $H_{21T}(p_1, p_2)$, $H_{22T}(p_1, p_2)$ and $H_{23T}(p_1, p_2)$, and obtained from the following equation:

$$\begin{pmatrix} H_{21T}(p_1, p_2) \\ H_{22T}(p_1, p_2) \\ H_{23T}(p_1, p_2) \end{pmatrix} = W^{-1}(p_1, p_2) \times \begin{pmatrix} 0 \\ (L_2 - D_2(p_1 + p_2) + \gamma_2(p_1 + p_2)) \cdot \prod_{i=1}^2 (H_{13T}(p_i) - H_{12T}(p_i)) - \\ -(\lambda_2 + \beta_2(p_1 + p_2)) \cdot \prod_{i=1}^2 H_{12T}(p_i) \\ L_2 - D_2(p_1 + p_2) + \gamma_2(p_1 + p_2) \cdot \prod_{i=1}^2 (H_{13T}(p_i) - H_{12T}(p_i)) \end{pmatrix} \quad (22)$$

After figuring out two-dimensional kernel $H_{23T}(p_1, p_2)$ from equation (22), dependences of a constant component of an output current in a frequency range shall be established taking into account both the parameters of an equivalent diagram and outer elements.

Then change in a constant component of a phototransistor output current after figuring out a two-dimensional kernel $H_{23T}(j\omega, -j\omega)$, according to (9), is the following:

$$\Delta I_{OUT0} = \frac{1}{2} I_{IN}^2 H_{23T}(j\omega, -j\omega). \quad (23)$$

Thus, application of the method of Volterra – Wiener series allows defining dependences of a phototransistor output current on the input signal parameters and evaluating the influence of parameters of a phototransistor itself and outer elements on the distortion of the signals transferred.

Similarly, change in the PHT first harmonic depending on nonlinearities in a phototransistor is defined. The first harmonic is observed at the output of linear and

cube systems. In order to establish the first harmonic at the output of a cube system, three-dimensional kernels shall be calculated. A matrix equation that is used to figure out the aforementioned kernels is the following:

$$\begin{pmatrix} H_{31T}(p_1, p_2, p_3) \\ H_{32T}(p_1, p_2, p_3) \\ H_{33T}(p_1, p_2, p_3) \end{pmatrix} = W^{-1}(p_1 + p_2 + p_3) \times \begin{pmatrix} 0 \\ (L_3 - D_3(p_1 + p_2 + p_3) + \gamma_3(p_1 + p_2 + p_3)) \cdot \prod_{i=1}^3 (K_{13T}(p_i) - K_{12T}(p_i)) - \\ -(\lambda_3 + \beta_3(p_1 + p_2 + p_3)) \cdot \prod_{i=1}^3 K_{12T}(p_i) \\ L_3 - D_3(p_1 + p_2 + p_3) + \gamma_3(p_1 + p_2 + p_3) \cdot \prod_{i=1}^3 (K_{13T}(p_i) - K_{12T}(p_i)) \end{pmatrix} \quad (24)$$

After calculating three-dimensional kernel $H_{33FT}(p_1, p_2, p_3)$ from (10), change output current first harmonic or phototransistor may be calculated [3].

$$\Delta I_{T1} = \frac{3}{4} I_{IN}^3 |H_{33T}(j\omega, j\omega, -j\omega)|. \quad (25)$$

Fig. 2 presents dependences change the first harmonic output current of a phototransistor on magnitude and frequency of an input signal.

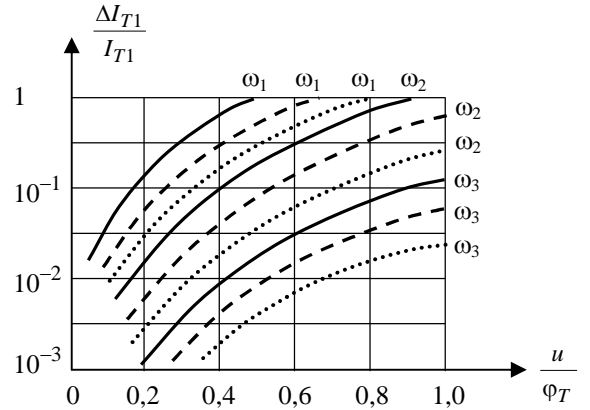

Fig. 2. Dependences of change in the first harmonic of an output current of a relative phototransistor on an input signal ($\omega_1 = 0,1\omega_{T0}$, $\omega_2 = 0,25\omega_{T0}$, $\omega_3 = 0,5\omega_{T0}$, $-I_{e0} = 1mA$, $--I_{e0} = 5mA$, $\cdots I_{e0} = 10mA$)

Conclusions

1. For investigating influence of a phototransistor as an optical device on signal distortions due to PHT nonlinearities, the method of Volterra – Wiener functional series has been offered.

2. A phototransistor model has been introduced as well as simulation of PHT nonlinearities having the main influence on the quality of the transferred signals has been carried out.

3. According to the provided equivalent diagram and using the method of Volterra – Wiener series, kernels of the respective linear, square and cube systems have been

figured out. According to them, changes in an operation mode of a phototransistor within a frequency range influenced by an input signal have been defined taking into account PHT parameters and outer elements.

References

1. **Anilionienė J.** Netiesiškumų optinėse ryšio sistemose tyrimas // Elektronika ir elektrotechnika. – 2005. – Nr. 1(57). – P. 36–41.

2. **Proakis J. G.** Digital Communications. 4th ed. – McGraw-Hill, NY, 2001. – 1002 p.

3. **Naraynan S.** Transistor Distortion Analysis Using Volterra Series // Technical Journal. – May 1976. – P. 21–31.

4. **Pocholle J. P.** Mesure des caracteristiques frequenielles des fibres optiques multimodes // Revue Technique THOMSON. – CSF. – 1981. – Vol. 13, No. 4. – P. 32–38.

Received 2008 04 19

J. Anilionienė. Analysis of Nonlinearities in Phototransistors // Electronics and Electrical Engineering. – Kaunas: Technologija, 2008. – No. 7(87). – P. 19–22.

A phototransistor model taking into account the main nonlinearities is introduced. For defining influence of nonlinearities on signal distortion, the method of Volterra – Wiener series has been offered. Simulation of phototransistor nonlinearities has been carried out considering nonlinearities of junction currents of an emitter and collector and their capacitances. Operational equation systems for an equivalent diagram of a phototransistor have been composed and analytic calculation expressions of functional series kernels have been obtained. Dependences of changes in constant components and in a first harmonic output current on input signal parameters have been presented. Il. 2, bibl. 4 (in English; summaries in English, Russian and Lithuanian).

Ю. Анилёнене. Исследование нелинейностей в фототранзисторах // Электроника и электротехника. – Каунас: Технология, 2008. – № 7(87). – С. 19–22.

Представлена модель фототранзистора, учитывающая основные его нелинейности. Влияние этих нелинейностей в искажении передаваемых сигналов оцениваются применяя функциональных рядов Вольтера-Винера. Осуществлено моделирование нелинейностей фототранзистора, учитывая нелинейность емкостей и токов эмиттерного и коллекторного переходов. Составлены системы уравнений в операционной форме для эквивалентной схемы фототранзистора и получены аналитические выражения для вычисления соответствующих рядов. Представлены зависимости первой гармоники выходного сигнала от величины частоты возбуждающего сигнала. Ил. 2, библи. 4 (на английском языке; рефераты на английском, русском и литовском яз.).

J. Anilionienė. Fototranzistorių netiesiškumų tyrimas // Elektronika ir elektrotechnika. – Kaunas: Technologija, 2008. – Nr. 7(87). – P. 19–22.

Pateiktas fototranzistoriaus modelis, sudarytas atsižvelgiant į pagrindinius netiesiškumus. Jų įtakai signalų iškreipimams įvertinti pasiūlytas Volterio ir Vinerio eilučių metodas. Atliktas fototranzistoriaus netiesiškumų modeliavimas, įvertinus emiterio ir kolektoriaus sandūrų srovių ir jų talpų netiesiškumus. Sudarytos lygčių sistemos operacine forma fototranzistoriaus ekvivalentinei schemai ir gautos analitinės išraiškos funkcinių eilučių branduoliams skaičiuoti. Pateiktos ir pirmos harmonikos išėjimo srovės pokyčių priklausomybės nuo įėjimo signalo parametrų. Il. 2., bibl. 4 (anglų kalba; santraukos anglų, rusų ir lietuvių k.).